

Italgroup[®]

HYDRAULIC MOTORS

ITALY



IAC

Dual displacement hydraulic motors

All partial or total reproduction and copy without written authorization of ItalgrouP S.r.l. is strictly forbidden.
©2016 ITALGROUP S.R.L. - ALL RIGHTS RESERVED -

**COMPANY WITH
QUALITY SYSTEM
CERTIFIED BY DNV GL
= ISO 9001 =**

ITALGROUP SRL

IAC SERIES

GENERAL CATALOGUE

INDEX

INTRODUCTION - GENERAL INFORMATION	Pag	4 - 5
INTRODUCTION - PRELIMINARY SELECTION	“	6
INTRODUCTION - ORDERING CODE	“	7
INTRODUCTION - TECHNICAL DATA	“	8 - 14
HYDRAULIC FLUID RECOMMENDATIONS	“	16 - 17
DRAIN RECOMMENDATIONS	“	18
FLUSHING	“	19
SHAFT SEAL FEATURES	“	20 - 21
FORMULAS - CONVERSIONS	“	22
INSTRUCTIONS AND ADVICES	“	24 - 33
IAC H1	“	35 - 48
IAC H3	“	49 - 60
IAC H4	“	61 - 72
IAC H5	“	73 - 84
IAC H55	“	85 - 94
IAC H6	“	95 - 106
IAC H7	“	107-120

<u>MOTOR DISTRIBUTORS</u>	“	122
<u>ADAPTOR FLANGES</u>	“	123
<u>SPLINED BILLETS</u>	“	124 -125
<u>TACHOMETERS</u>	“	126 -128
<u>VALVES</u>	“	130 -139
<u>TROUBLESHOOTING</u>	“	140 -141
<u>CONTACT US - REACH US</u>	“	142

The data specified into the catalogue are for product description purpose only and must not be interpreted as warranted characteristics in legal sense. Italgroup S.r.l. reserves the right to implement modifications without notice. All partial or total reproduction and copy without written authorization of Italgroup S.r.l. is strictly forbidden.

*Carefully read the use and maintenance manual before start-up the motor. The use and maintenance manual must be placed near to motor installation location in order to guarantee operators easy access to the instruction manual. For further information please contact Italgrou**p**.*

Motor description

IAC series motors are dual displacement radial piston hydraulic motors (generally indicated as LSHT motors, low speed high torque motors) with a rotating shaft (1) and a stationary housing (2). The pistons (3) are located radially and the working fluid provide the mechanical force that push the pistons against the eccentric cam (4), providing the shaft output torque. The inlet and outlet flow to and from the pistons is regulated by a distributor (5) that provides the oil distribution correct timing. The pistons transfer the forces to the eccentric shaft through a connecting rod (6). Acting in the adequate way (increasing or reducing the oil flow coming from the pump) the motor rotational speed can be increased or reduced. In addition, there is an hydraulic mechanism (7) that control the motor displacement.

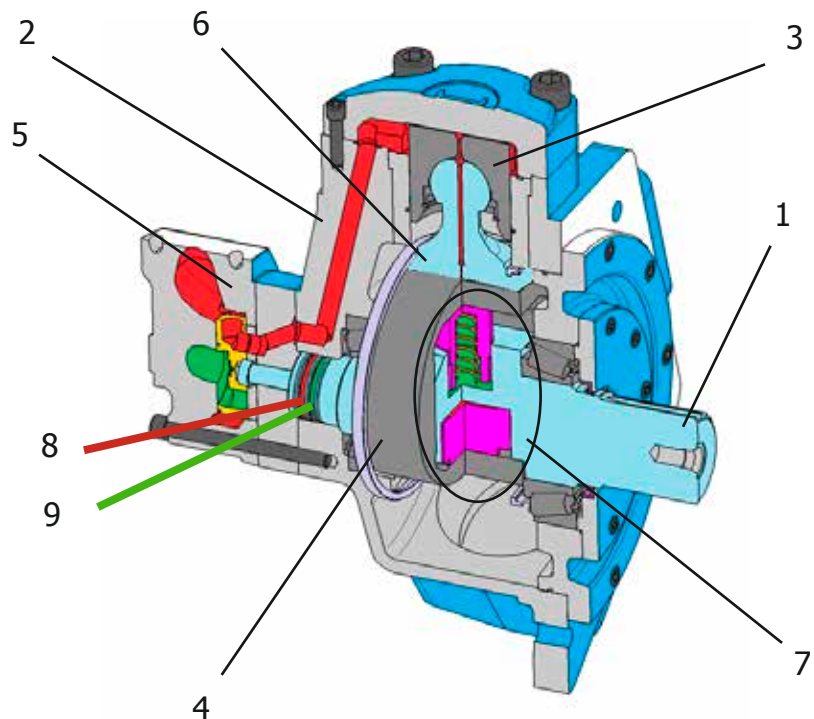

There are two pressure commands (8 and 9) that are connected to the two displacement change pistons: an external valve (that can be for example a solenoid operated valve or an hydraulically operated valve) supplies pressure to one of the two pistons, depending by the user needs. The pistons move and therefore pull the eccentric cam, this cause the displacement variation. In this way we can have two different displacement in the same motor.



IAC SERIES

Hydraulic motors of the IAC series are dual displacement crankshaft radial piston motors. Thanks to great variety of accessories IAC series can be used in a wide range of applications such as:

- Marine equipments
- Winches
- Offshore equipments
- Conveyors
- Steel bending machines
- Fork lifts trucks
- Skid steer loaders
- Dumpers
- Agricultural and forestry machines
- Municipal vehicles
- Airport machinery

Product Features:

- ✓ High volumetric and mechanical efficiencies
- ✓ Very smooth running at low speeds
- ✓ High starting torque / constant torque
- ✓ Wide speed range
- ✓ Compact Design
- ✓ Low maintenance and high reliability
- ✓ Bi-directional
- ✓ Dual speed
- ✓ High radial and axial force allowed
- ✓ Freewheeling
- ✓ Speed sensor available
- ✓ Built-in valves available

Overview

Motor	Max torque @275 bar [Nm]	Continuous power with flushing [kW]	Continuous power without flushing [kW]
IAC 195 H1	765	45	36
IAC 250 H1	995	48	38
IAC 500 H3	1885	78	65
IAC 800 H4	3150	125	105
IAC 1600 H5	6350	172	142
IAC 2200 H55	8880	170	140
IAC 3000 H6	12800	270	180
IAC 4600 H7	19300	290	195
IAC 5400 H7	22200	265	195

Interchangeability chart

STAFFA - KAWASAKI

Italgroupp motor code	Staffa motor code
IAC 500/B30 H3	HMC 30
IAC 800/B45 H4	HMC 45
IAC 1400 H5	HMC 80
IAC 2200 H55	HMC 125
IAC 3000 H6	HMC 200
IAC 4600 H7	HMC 270
IAC 5400 H7	HMC 325

PARKER/DENISON-CALZONI

Italgroupp motor code	Parker motor code
IAC 500/C H3	MRD 450 - MRDE 500
IAC 700/C H4	MRD 700 - MRDE 800
IAC 1400/C H5	MRD 1100 - MRDE 1400
IAC 3000/C H6	MRD 2800 - MRDE 3100

KAYABA

Italgroupp motor code	Kayaba motor code
IAC 800/MRH H4	MRH2-45
IAC 1600/MRH H5	MRH2-95
IAC 3000/MRH H6	MRH2-190
IAC 4600/MRH H7	MRH2-270
IAC 6000/MRH H7	MRH2-375

The data specified into the catalogue are for product description purpose only and must not be interpreted as warranted characteristics in legal sense. Italgroupp S.r.l. reserves the right to implement modifications without notice. All partial or total reproduction and copy without written authorization of Italgroupp S.r.l. is strictly forbidden.

INTRODUCTION - IAC ORDERING CODE

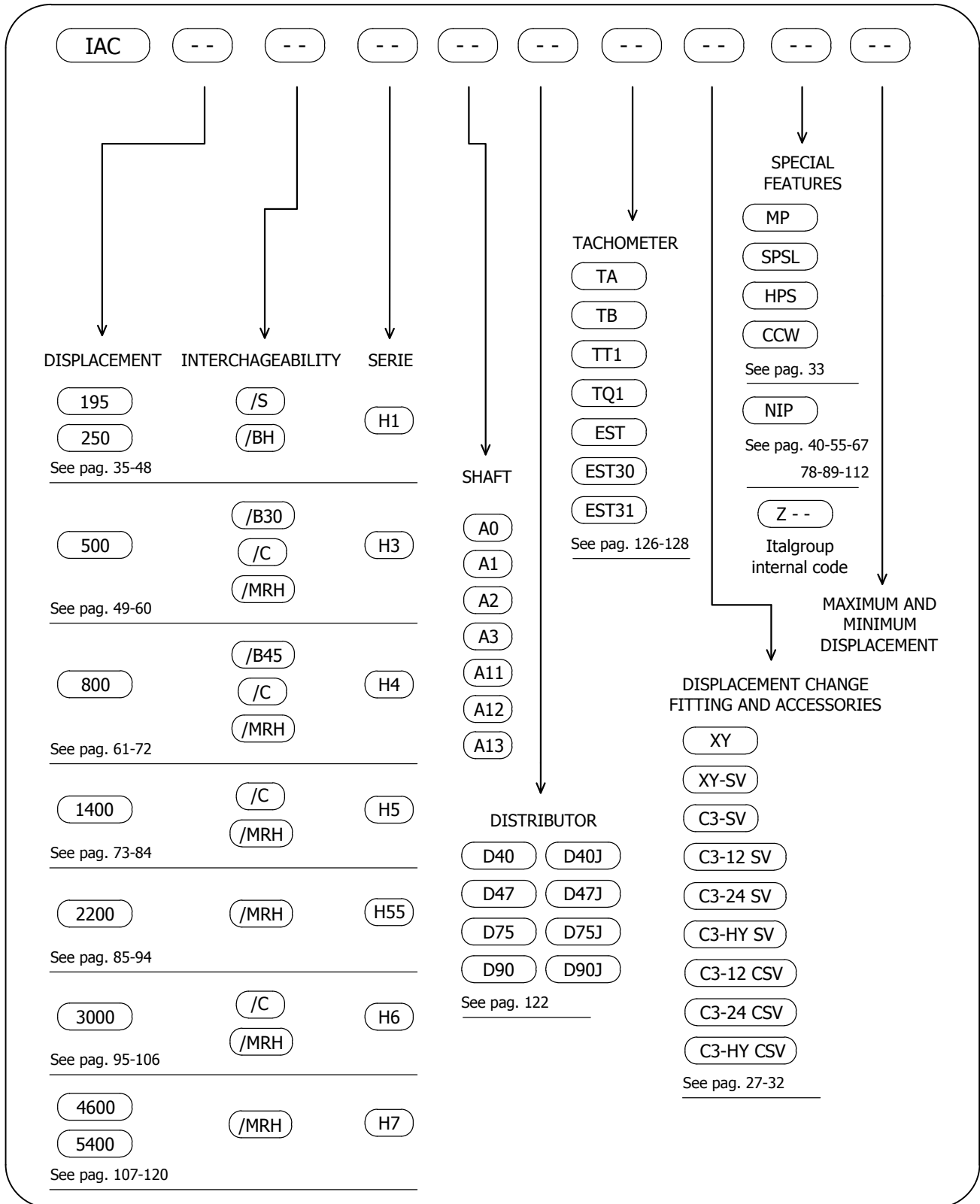

The data specified into the catalogue are for product description purpose only and must not be interpreted as warranted characteristics in legal sense. ItalgrouP S.r.l. reserves the right to implement modifications without notice. All partial or total reproduction and copy without written authorization of ItalgrouP S.r.l. is strictly forbidden.

IAC 195 H1

Displacement (*)	[cc]	195	175	150	125	100	95	75	69
Th. specific torque	[Nm/bar]	3,1	2,8	2,4	2	1,6	1,5	1,2	1,1
Continuous speed	[rpm]	850	850	1000	1000	1050	1050	1100	1100
Peak speed	[rpm]	950	1050	1150	1150	1200	1200	1250	1250
Minimum speed	[rpm]	3	3	3	4	4	4	5	5
Mechanical efficiency	[%]	89,5	89,2	89	88,5	88	87,8	87	85,5
Starting efficiency	[%]	84,5	84,2	84	83,5	83	82	80	77
Continuous power (**)	[kW]	36	34	32	30	28	26	20	18
Cont. power with flushing	[kW]	45	42	38	36	35	32	26	24
Continuous pressure	[bar]	270	270	270	270	250	250	250	250
Intermittent pressure	[bar]	310	310	310	310	310	310	310	310
Peak pressure	[bar]	350	350	350	350	350	350	350	350
Flushing flow	[l/min]	6	6	6	6	6	6	6	6
Dry weight	[kg]	26	26	26	26	26	26	26	26

IAC 250 H1

Displacement (*)	[cc]	257	232	195	175	150	125	100	95
Th. specific torque	[Nm/bar]	4,1	3,7	3,1	2,8	2,4	2	1,6	1,5
Continuous speed	[rpm]	810	810	850	850	1000	1000	1050	1050
Peak speed	[rpm]	920	920	950	1050	1150	1150	1200	1200
Minimum speed	[rpm]	3	3	3	3	3	4	4	5
Mechanical efficiency	[%]	88,5	88,2	88	87,5	87	86,8	86	84,5
Starting efficiency	[%]	83,5	83,2	83	82,5	82	81	79	76
Continuous power (**)	[kW]	38	37	36	34	32	30	28	28
Cont. power with flushing	[kW]	48	46	45	43	40	38	34	32
Continuous pressure	[bar]	250	250	250	250	250	250	250	250
Intermittent pressure	[bar]	310	310	310	310	310	310	310	310
Peak pressure	[bar]	350	350	350	350	350	350	350	350
Flushing flow	[l/min]	6	6	6	6	6	6	6	6
Dry weight	[kg]	26	26	26	26	26	26	26	26

(*) Different displacements can be available on request. Please contact ItalgrouP S.r.l. for more information.

(**) The continuous power and the continuous power with flushing are the output maximum power. To estimate the input power divide the output power by the mechanical efficiency. For example: if required output power is 40 kW and starting efficiency is 90%, estimated required power is $40/0.9 = 44,44$ kW.

Hydrostatic pressure test: 420 bar.

Temperature range: -30 / 70 °C.

IAC 500 H3

Displacement (*)	[cc]	492	442	393	344	292
Th. specific torque	[Nm/bar]	7,8	7	6,3	5,5	4,7
Continuous speed	[rpm]	500	550	600	630	630
Peak speed	[rpm]	600	650	680	700	700
Minimum speed	[rpm]	2	2	2	2	2
Mechanical efficiency	[%]	87,5	86	85	83,6	82,4
Starting efficiency	[%]	82,5	81	80	77,2	74,3
Continuous power (**)	[kW]	65	65	65	60	50
Cont. power with flushing	[kW]	78	78	78	70	60
Continuous pressure	[bar]	270	270	270	270	270
Intermittent pressure	[bar]	310	310	310	310	310
Peak pressure	[bar]	350	350	350	350	350
Flushing flow	[l/min]	8	8	8	8	8
Dry weight	[kg]	68	68	68	68	68

Displacement (*)	[cc]	255	197	147	98
Th. specific torque	[Nm/bar]	4,1	3,1	2,3	1,6
Continuous speed	[rpm]	650	700	700	700
Peak speed	[rpm]	750	800	900	1000
Minimum speed	[rpm]	3	3	3	4
Mechanical efficiency	[%]	82	80	78	73,4
Starting efficiency	[%]	69,6	62,1	52	30
Continuous power (**)	[kW]	48	38	24	15
Cont. power with flushing	[kW]	55	41	28	18
Continuous pressure	[bar]	270	250	250	250
Intermittent pressure	[bar]	310	310	310	310
Peak pressure	[bar]	350	350	350	350
Flushing flow	[l/min]	8	8	8	8
Dry weight	[kg]	68	68	68	68

(*) Different displacements can be available on request. Please contact ItalgrouP S.r.l. for more information.

(**) The continuous power and the continuous power with flushing are the output maximum power. To estimate the input power divide the output power by the mechanical efficiency. For example: if required output power is 60 kW and starting efficiency is 82,5%, estimated required power is $60/0.825 = 72,7$ kW.

Hydrostatic pressure test: 420 bar.

Temperature range: -30 / 70 °C.

IAC 800 H4

Displacement (*)	[cc]	792	660	575	493	410
Th. specific torque	[Nm/bar]	12,6	10,5	9,2	7,8	6,5
Continuous speed	[rpm]	450	550	620	650	650
Peak speed	[rpm]	550	700	720	750	800
Minimum speed	[rpm]	2	2	2	2	2
Mechanical efficiency	[%]	90,8	90,4	88,5	88	87,4
Starting efficiency	[%]	84,8	84,4	82,6	79	75
Continuous power (**)	[kW]	105	92	82	70	54
Cont. power with flushing	[kW]	125	110	98	84	65
Continuous pressure	[bar]	270	270	270	270	270
Intermittent pressure	[bar]	310	310	310	310	310
Peak pressure	[bar]	350	350	350	350	350
Flushing flow	[l/min]	10	10	10	10	10
Dry weight	[kg]	92	92	92	92	92

Displacement (*)	[cc]	328	273	245	165
Th. specific torque	[Nm/bar]	5,2	4,3	3,9	2,6
Continuous speed	[rpm]	700	700	700	700
Peak speed	[rpm]	800	850	850	900
Minimum speed	[rpm]	2	2	3	3
Mechanical efficiency	[%]	84,5	82,4	82	60,2
Starting efficiency	[%]	70,2	68,3	60,8	43,3
Continuous power (**)	[kW]	54	42	40	18
Cont. power with flushing	[kW]	65	50	48	24
Continuous pressure	[bar]	250	250	250	250
Intermittent pressure	[bar]	310	310	310	310
Peak pressure	[bar]	350	350	350	350
Flushing flow	[l/min]	10	10	10	10
Dry weight	[kg]	92	92	92	92

(*) Different displacements can be available on request. Please contact ItalgrouP S.r.l. for more information.

(**) The continuous power and the continuous power with flushing are the output maximum power. To estimate the input power divide the output power by the mechanical efficiency. For example: if required output power is 100 kW and starting efficiency is 90.8%, estimated required power is $100/0.908 = 110,1$ kW.

Hydrostatic pressure test: 420 bar.

Temperature range: -30 / 70 °C.

IAC 1400 H5

Displacement (*)	[cc]	1600	1499	1393	1313	1235	1150	1070	980	900	820
Th. specific torque	[Nm/bar]	24,5	23,9	22,2	20,9	19,7	18,3	17	15,6	14,3	13
Continuous speed	[rpm]	370	400	410	435	440	460	480	490	495	520
Peak speed	[rpm]	450	500	500	500	550	550	575	600	600	600
Minimum speed	[rpm]	1	1	1	1	1	1	1	1	1	2
Mechanical efficiency	[%]	94,2	94	93,9	93,7	93,5	93,4	93,2	93	92,6	92,3
Starting efficiency	[%]	88,2	88	86,5	85,3	85,1	82,6	81,3	79,8	77,9	76
Continuous power (***)	[kW]	142	140	135	130	130	125	120	115	110	105
Cont. power with flushing	[kW]	172	170	165	155	155	150	145	138	132	126
Continuous pressure	[bar]	270	270	270	270	270	270	270	270	270	270
Intermittent pressure	[bar]	310	310	310	310	310	310	310	310	310	310
Peak pressure	[bar]	350	350	350	350	350	350	350	350	350	350
Flushing flow	[l/min]	12	12	12	12	12	12	12	12	12	12
Dry weight	[kg]	173	173	173	173	173	173	173	173	173	173

Displacement (*)	[cc]	737	655	574	492	410	328	246	164	82	0
Th. specific torque	[Nm/bar]	11,7	10,4	9,1	7,8	6,5	5,2	3,9	2,6	1,3	0
Continuous speed	[rpm]	545	600	600	600	600	600	600	600	1000	1000
Peak speed	[rpm]	650	700	700	700	800	800	800	800	1200	1500
Minimum speed	[rpm]	2	2	2	2	2	3	3	3	-	-
Mechanical efficiency	[%]	91	89,3	87	83	81,7	75,5	65,7	60,5	0	0
Starting efficiency	[%]	72,9	83,2	65	59,2	51	39	18	0	0	0
Continuous power (***)	[kW]	105	105	95	70	55	40	25	18	0	0
Cont. power with flushing	[kW]	126	126	110	90	75	55	35	22	0	0
Continuous pressure	[bar]	250	250	250	250	250	250	250	250	17(**)	17(**)
Intermittent pressure	[bar]	310	310	310	310	310	310	310	310	17(**)	17(**)
Peak pressure	[bar]	350	350	350	350	350	350	350	350	17(**)	17(**)
Flushing flow	[l/min]	12	12	12	12	12	12	12	12	15	15
Dry weight	[kg]	173	173	173	173	173	173	173	173	173	173

(*) Different displacements can be available on request. Please contact ItalgrouP S.r.l. for more information.

(**) Pressure limits at 1000 rpm. For lower speeds the values can be increased. Contact ItalgrouP for more information.

(***) The continuous power and the continuous power with flushing are the output maximum power. To estimate the input power divide the output power by the mechanical efficiency. For example: if required output power is 120 kW and starting efficiency is 88,2%, estimated required power is $120/0.882 = 136$ kW.

Hydrostatic pressure test: 420 bar.

Temperature range: -30 / 70 °C.

IAC 2200 H55

Displacement (*)	[cc]	2200	2049	1970	1800	1640	1470	1310	1150	980	820
Th. specific torque	[Nm/bar]	35	32,6	31,3	28,6	26,1	23,4	20,9	18,3	15,6	13,1
Continuous speed	[rpm]	280	305	320	350	380	410	440	470	610	620
Peak speed	[rpm]	320	340	360	400	430	470	500	540	700	700
Minimum speed	[rpm]	1	1	1	1	1	1	1	1	1	2
Mechanical efficiency	[%]	92,2	92,2	92,2	92,2	91	90	88	86,5	82,2	81,8
Starting efficiency	[%]	81	80,6	79,6	77,5	74,6	71,5	67,5	62,2	55,3	45,8
Continuous power (***)	[kW]	140	140	135	125	116	108	100	90	83	75
Cont. power with flushing	[kW]	170	170	165	155	145	135	127	110	105	90
Continuous pressure	[bar]	270	270	270	270	270	270	270	270	270	250
Intermittent pressure	[bar]	310	310	310	310	310	310	310	310	310	310
Peak pressure	[bar]	350	350	350	350	350	350	350	350	350	350
Flushing flow	[l/min]	10	10	10	10	10	10	10	10	10	10
Dry weight	[kg]	210	210	210	210	210	210	210	210	210	210

Displacement (*)	[cc]	655	490	330	160	82	0
Th. specific torque	[Nm/bar]	10,4	7,8	5,3	2,5	1,3	0
Continuous speed	[rpm]	620	640	640	640	1000	1000
Peak speed	[rpm]	720	720	800	800	1200	1500
Minimum speed	[rpm]	2	2	3	5	-	-
Mechanical efficiency	[%]	78,2	76	73	26	0	0
Starting efficiency	[%]	31,5	0	0	0	0	0
Continuous power (***)	[kW]	65	50	25	5	0	0
Cont. power with flushing	[kW]	80	65	40	10	0	0
Continuous pressure	[bar]	250	250	250	250	17(**)	17(**)
Intermittent pressure	[bar]	310	310	310	310	17(**)	17(**)
Peak pressure	[bar]	350	350	350	350	17(**)	17(**)
Flushing flow	[l/min]	10	10	10	12	15	15
Dry weight	[kg]	210	210	210	210	210	210

(*) Different displacements can be available on request. Please contact ItalgrouP S.r.l. for more information.

(**) Pressure limits at 1000 rpm. For lower speeds the values can be increased. Contact ItalgrouP for more information.

(***) The continuous power and the continuous power with flushing are the output maximum power. To estimate the input power divide the output power by the mechanical efficiency. For example: if required output power is 150 kW and starting efficiency is 86%, estimated required power is $150/0.86 = 174,4$ kW.

Hydrostatic pressure test: 420 bar.

Temperature range: -30 / 70 °C.

IAC 3000 H6

Displacement (*)	[cc]	3085	2950	2790	2620	2460	2290	2130	1970	1800	1640
Th. specific torque	[Nm/bar]	49,1	47	44,4	41,7	39,2	36,5	33,9	31,4	28,7	26,1
Continuous speed	[rpm]	235	240	245	250	250	265	285	305	340	370
Peak speed	[rpm]	280	280	300	300	300	320	340	350	400	420
Minimum speed	[rpm]	1	1	1	1	1	1	1	1	1	1
Mechanical efficiency	[%]	95	94,5	94,2	94	93,7	93,5	92,8	92,3	92	91
Starting efficiency	[%]	86	85,4	84,4	83,6	82,4	82	80,2	78	76	73
Continuous power (***)	[kW]	180	180	180	168	158	153	143	132	122	115
Cont. power with flushing	[kW]	270	270	270	253	238	228	212	196	185	175
Continuous pressure	[bar]	270	270	270	270	270	270	270	270	270	270
Intermittent pressure	[bar]	310	310	310	310	310	310	310	310	310	310
Peak pressure	[bar]	350	350	350	350	350	350	350	350	350	350
Flushing flow	[l/min]	12	12	12	12	12	12	12	12	12	12
Dry weight	[kg]	308	308	308	308	308	308	308	308	308	308

Displacement (*)	[cc]	1470	1310	1150	980	820	670	490	330	160	82	0
Th. specific torque	[Nm/bar]	23,4	20,9	18,3	15,6	13,1	10,7	7,8	5,2	2,5	1,3	0
Continuous speed	[rpm]	400	425	455	490	520	600	600	600	600	1000	1000
Peak speed	[rpm]	450	475	500	540	580	700	700	800	800	1200	1500
Minimum speed	[rpm]	1	1	1	1	2	2	2	3	5	-	-
Mechanical efficiency	[%]	90,5	88	86,2	82,3	81,7	78	76	73,2	25	0	0
Starting efficiency	[%]	70	66,4	62	55,4	46,3	33	0	0	0	0	0
Continuous power (***)	[kW]	106	100	100	100	90	80	70	40	8	0	0
Cont. power with flushing	[kW]	160	150	150	150	135	96	90	60	11	0	0
Continuous pressure	[bar]	270	250	250	250	250	250	250	250	250	17(**)	17(**)
Intermittent pressure	[bar]	310	310	310	310	310	310	310	310	310	17(**)	17(**)
Peak pressure	[bar]	350	350	350	350	350	350	350	350	350	17(**)	17(**)
Flushing flow	[l/min]	12	12	12	12	12	12	12	12	12	15	15
Dry weight	[kg]	308	308	308	308	308	308	308	308	308	308	308

(*) Different displacements can be available on request. Please contact ItalgrouP S.r.l. for more information.

(**) Pressure limits at 1000 rpm. For lower speeds the values can be increased. Contact ItalgrouP for more information.

(***) The continuous power and the continuous power with flushing are the output maximum power. To estimate the input power divide the output power by the mechanical efficiency. For example: if required output power is 150 kW and starting efficiency is 86%, estimated required power is $150/0.86 = 174,4$ kW.

Hydrostatic pressure test: 420 bar.

Temperature range: -30 / 70 °C.

IAC 4600 H7

Displacement (*)	[cc]	4617	4177	3650	3280	2950	2620	2290	1970
Th. specific torque	[Nm/bar]	73,5	66,5	58,1	52,2	47	41,7	36,5	31,4
Continuous speed	[rpm]	150	158	168	175	210	235	275	305
Peak speed	[rpm]	170	185	210	230	255	280	330	380
Minimum speed	[rpm]	1	1	1	1	1	1	1	1
Mechanical efficiency	[%]	95,3	95,1	94,5	94,4	93,3	92,4	91,5	90,1
Starting efficiency	[%]	85,1	84	83,3	82,5	81,2	80,1	78	75,2
Continuous power (***)	[kW]	195	190	175	155	145	135	120	110
Cont. power with flushing	[kW]	290	270	250	235	215	200	180	165
Continuous pressure	[bar]	270	270	270	270	270	270	270	250
Intermittent pressure	[bar]	310	310	310	310	310	310	310	310
Peak pressure	[bar]	350	350	350	350	350	350	350	350
Flushing flow	[l/min]	12	12	12	12	12	12	12	12
Dry weight	[kg]	405	405	405	405	405	405	405	405

Displacement (*)	[cc]	1640	1310	980	655	492	328	164	82	0
Th. specific torque	[Nm/bar]	26,1	20,9	15,6	10,4	7,8	5,2	2,6	0	0
Continuous speed	[rpm]	380	435	460	495	520	550	600	1000	1000
Peak speed	[rpm]	470	530	550	600	600	650	700	1200	1500
Minimum speed	[rpm]	1	1	1	2	2	3	6	-	-
Mechanical efficiency	[%]	86,5	83	78,4	76,2	66	46,4	25	0	0
Starting efficiency	[%]	72,4	67,2	58	41	23,7	0	0	0	0
Continuous power (***)	[kW]	110	95	75	50	45	25	10	0	0
Cont. power with flushing	[kW]	165	140	112	80	65	32	10	0	0
Continuous pressure	[bar]	250	250	250	250	250	250	250	17(**)	17(**)
Intermittent pressure	[bar]	310	310	310	310	310	310	310	17(**)	17(**)
Peak pressure	[bar]	350	350	350	350	350	350	350	17(**)	17(**)
Flushing flow	[l/min]	12	12	12	12	12	12	12	15	15
Dry weight	[kg]	405	405	405	405	405	405	405	405	405

(*) Different displacements can be available on request. Please contact ItalgrouP S.r.l. for more information.

(**) Pressure limits at 1000 rpm. For lower speeds the values can be increased. Contact ItalgrouP for more information.

(***) The continuous power and the continuous power with flushing are the output maximum power. To estimate the input power divide the output power by the mechanical efficiency. For example: if required output power is 160 kW and starting efficiency is 85,1%, estimated required power is $160/0.851 = 188$ kW.

Hydrostatic pressure test: 420 bar.

Temperature range: -30 / 70 °C.

IAC 5400 H7

Displacement (*)	[cc]	5326	5080	4915	4588	4097	3650	3280	2950	2620
Th. specific torque	[Nm/bar]	84,8	80,9	78,2	73	65,2	58,1	52,2	47	41,7
Continuous speed	[rpm]	130	135	140	150	160	170	190	215	230
Peak speed	[rpm]	145	150	155	165	185	210	235	260	290
Minimum speed	[rpm]	1	1	1	1	1	1	1	1	1
Mechanical efficiency	[%]	95,2	95	95	95	95	94,4	94,3	93,2	92
Starting efficiency	[%]	86	85,8	85,8	85,4	85,2	83	82,2	82	79,8
Continuous power (***)	[kW]	195	195	195	190	180	165	155	145	135
Cont. power with flushing	[kW]	265	260	260	255	245	230	230	215	200
Continuous pressure	[bar]	250	250	250	250	250	250	250	250	250
Intermittent pressure	[bar]	310	310	310	310	310	310	310	310	310
Peak pressure	[bar]	350	350	350	350	350	350	350	350	350
Flushing flow	[l/min]	12	12	12	12	12	12	12	12	12
Dry weight	[kg]	405	405	405	405	405	405	405	405	405

Displacement (*)	[cc]	2295	1640	1311	980	655	492	328	164	0
Th. specific torque	[Nm/bar]	36,5	26,1	20,9	15,6	10,4	7,8	5,2	1,6	0
Continuous speed	[rpm]	280	375	445	470	500	520	550	1000	1000
Peak speed	[rpm]	335	450	530	550	600	600	650	1200	1500
Minimum speed	[rpm]	1	1	1	1	2	2	3	-	-
Mechanical efficiency	[%]	91,5	86	82,3	78,3	76,2	66,2	46,5	0	0
Starting efficiency	[%]	77,7	72,1	67	58	41	24	0	0	0
Continuous power (***)	[kW]	125	125	95	95	60	40	28	0	0
Cont. power with flushing	[kW]	185	185	135	135	80	60	32	0	0
Continuous pressure	[bar]	250	250	250	250	250	250	250	17(**)	17(**)
Intermittent pressure	[bar]	310	310	310	310	310	310	310	17(**)	17(**)
Peak pressure	[bar]	350	350	350	350	350	350	350	17(**)	17(**)
Flushing flow	[l/min]	12	12	12	12	12	12	12	15	15
Dry weight	[kg]	405	405	405	405	405	405	405	405	405

(*) Different displacements can be available on request. Please contact ItalgrouP S.r.l. for more information.

(**) Pressure limits at 1000 rpm. For lower speeds the values can be increased. Contact ItalgrouP for more information.

(***) The continuous power and the continuous power with flushing are the output maximum power. To estimate the input power divide the output power by the mechanical efficiency. For example: if required output power is 160 kW and starting efficiency is 86%, estimated required power is $160/0.86 = 186$ kW.

Hydrostatic pressure test: 420 bar.

Temperature range: -30 / 70 °C.

The data specified into the catalogue are for product description purpose only and must not be interpreted as warranted characteristics in legal sense. ItalgrouP S.r.l. reserves the right to implement modifications without notice. All partial or total reproduction and copy without written authorization of ItalgrouP S.r.l. is strictly forbidden.

Fluid selection

In general, we recommend the use of hydraulic oils with minimum viscosity index of 95, with anti-wear additives (ISO HM and HV). Once normal working temperature is reached, the drain oil viscosity must be at least 35-50 cSt, preferably in the range from 40 to 60 cSt.

HE oils (ecological fluids) are allowed, but must be used with particular attention, because they can influence the motor seals compatibility, and can reduce motor performances and life. Please contact us in case of HE oils usage.

Optimal viscosity selection

Referring the first approximated selection to the room temperature, we advice the following:

Room temperature	Oil
-20°C/0°C	BP ENERGOL HLP – HM 22
-15°C/+5°C	BP ENERGOL HLP – HM 32
-8°C/+15°C	BP ENERGOL HLP – HM 46
0°C/+22°C	BP ENERGOL HLP – HM 68
+8°C/+30°C	BP ENERGOL HLP – HM 100
-20°C/+5°C	BP BARTRAN HV 32
-15°C/+22°C	BP BARTRAN HV 46
0°C/+30°C	BP BARTRAN HV 68

ATF (automatic transmission fluid) oils, SAE 10-20-30 W oils, multi-grade motor oils (SAE 15 W 40, 10 W 40), universal oils, can also be used. Always fill the motor (please refer to the “DRAIN RECOMMENDATIONS” section) with the selected hydraulic fluid before motor start-up. During cold start-up avoid high-speed operation until the system reach the working temperature, in order to provide an adequate lubrication. Every 5-8 °C of increase respect to the optimal working temperature for the selected oil, the hydraulic fluid life decrease of about 40-50% (refer to “OXIDATION” section). Consequently, the motor lifetime will be affected by the working temperature increase respect to the optimal working temperature of the selected oil. The maximum continuous working temperature is 70 °C, the temperature must be measured from motor drain line. If the motor doesn't have a drain line, the temperature must be evaluated at the return line port.

Fire resistant oil limitations

	Max cont. Pressure [bar]	Max int. Pressure [bar]	Max Speed [rpm]
HFA, 5-95% oil-water	103	138	50%
HFB, 60-40% oil-water	138	172	100%
HFC, water-glycol	103	138	50%
HFD, ester phosphate	250	293	100%

Filtration

Hydraulic systems oil must always be filtered.

The choice of filtration grade derives from needs of service life and money spent. In order to obtain stated service life it is important to follow our recommendations concerning filtration grade.

When choosing the filter it is important to consider the amount of dirt particles that filter can absorb and still operate satisfactorily. For that reason we recommend filters showing when you need to substitute filtering cartridge.

- 25 µm filtration required in most applications
- 10 µm filtration in closed circuit applications

Oxidation

Hydraulic oil oxidizes with time of use and temperature. Oxidation causes changes in colour and smell, acidity increase or sludge formation in the tank. Oxidation rate increases rapidly at surface temperatures above 60°C, in these situations oil should be checked more often.

The oxidation process increases the acidity of the fluid; the acidity is stated in terms of the “neutralization number”. Oxidation is usually slow at the beginning and then it increases rapidly.

A sharp increase (by a factor of 2 to 3) in neutralization number between inspections shows that oil has oxidized too much and should be replaced immediately.

Water content

Oil contamination by water can be detected by sampling from the bottom of the tank. Most hydraulic oils repel the water, which then collects at the bottom of the tank. This water must be drained off at regular intervals. Certain types of transmission oils and engine oils emulsify the water; this can be detected by coatings on filter cartridges or a change in the colour of the oil. In such cases, obtain your oil supplier advice.

Degree of contamination

Heavy contamination of the oil causes wear rising in hydraulic system components. Contamination causes must be immediately investigated and remedied.

Analysis

It is recommended oil being analyzed every 6 months. The analysis should cover viscosity, oxidation, water content, additives and contamination.

Most oil suppliers are equipped to analyze oil state and to recommend appropriate action. Oil must be immediately replaced if the analysis shows that it is exhausted.

Motor axis horizontal

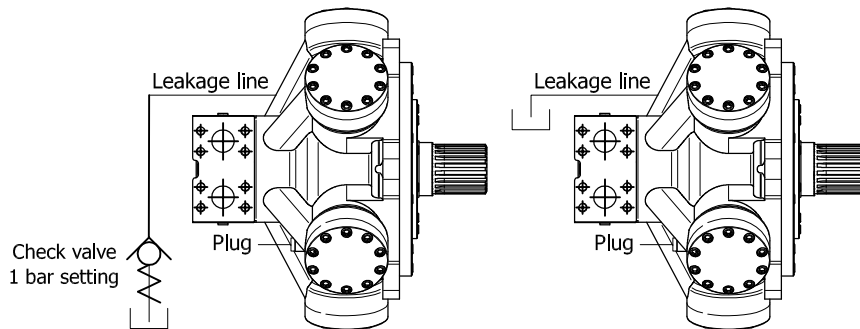

Motor axis vertical, shaft down

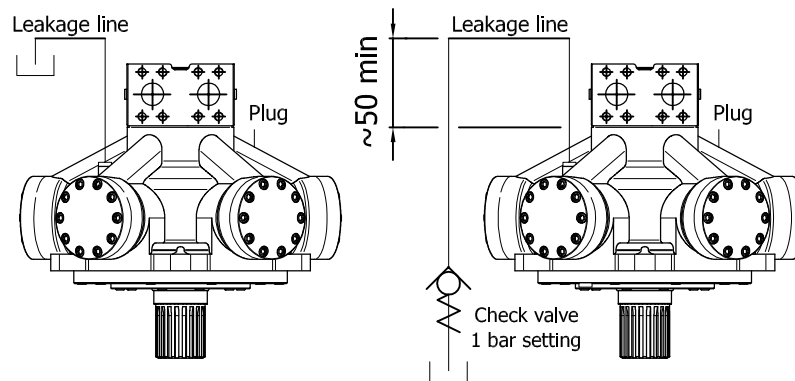

Motor axis vertical, shaft up

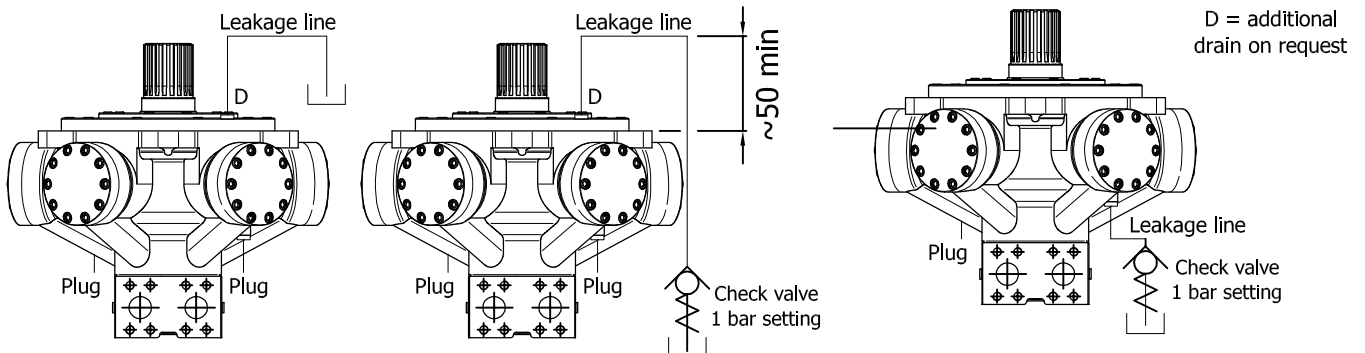

Leakage line connection

Always fill the motor with hydraulic fluid before start-up. Arrange piping in a way that the motor cannot drain off and cannot generate air bubbles into the motor case. Under certain conditions it may be necessary to arrange a check valve in order to help avoid the motor draining off. Always check carefully that the leakage line pressure doesn't overcome 10 bar pressure: therefore leakage lines must be shorter as possible and with a minimum flow resistance.

FLUSHING

Motor	Flushing flow Q_F [l/min]
IAC H1	6
IAC H3	8
IAC H4	10
IAC H5	12 - 15 (*)
IAC H6	12 - 15 (*)
IAC H7	12 - 15 (*)

Important note: the above value are approximated. The correct way to operate is the following: the flushing flow is adequate if during the motor operation the drain oil viscosity be at least 35-50 cSt, preferably in the range from 40 to 60 cSt.

Maximum continuous case pressure 10 bar (15 bar peak pressure). Special seals for 20-25 bar continuous case pressure are available upon request (ordering code: HPS).

(*) The flushing flow for lower displacements that are used for freewheeling at 1000 rpm, must be higher than flushing flow for normal working conditions, and around 15 l/min.

Flushing outlet port

Please note: the flushing outlet port must always be located in the highest possible position.

Maximum case pressure

10 bar continuous
15 bar peak

For standard IAC motors

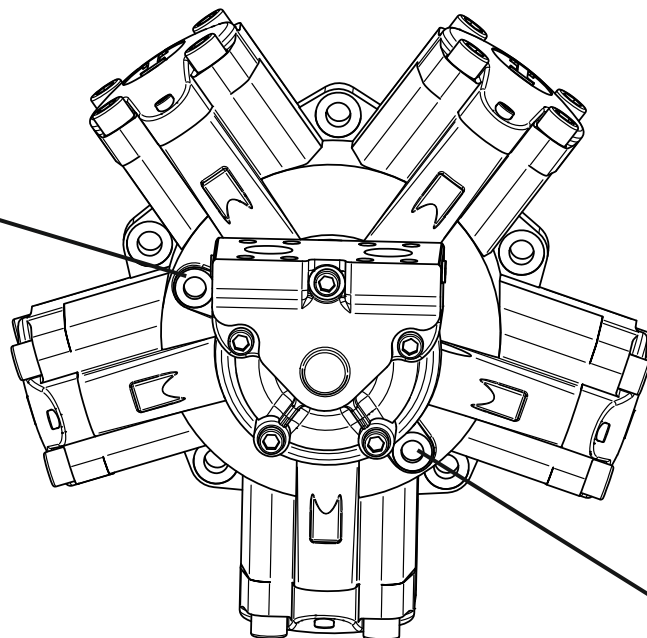

Flushing inlet port

Features	Type: BABSL Form: AS DIN 3760 Material: SIMRIT [®] 72 NBR 902 SIMRIT [®] 75 FKM 595
Material	SIMMERRING [®] radial shaft seal with rubber covered O.D., short, flexibility suspended, spring loaded sealing lip and additional dust lip: see Part B/SIMMERRING [®] , sections 1.1 and 2.
Application	Sealing lip and O.D.: – Acrylonitrile-butadiene rubber with 72 Shore A hardness (designation: SIMRIT [®] 72 NBR 902) – Fluoro rubber with 75 Shore A hardness (designation: SIMRIT [®] 75 FKM 595) Metal insert: – Plain steel DIN 1624 Spring: – Spring steel DIN 17223
Operating conditions	See Part B/ SIMMERRING [®] , sections 2. 4. Media: mineral oils, synthetic oils Temperature: -40°C to +100°C (SIMRIT [®] 72 NBR 902) -40°C to +160°C (SIMRIT [®] 75 FKM 595) Surface speed: up to 5 m/s Working pressure: see diagram on next page, pressure is function of surface speed (i.e. of rotating speed and shaft diameter)

STANDARD SHAFT SEAL FEATURES

Housing and machining criteria

See Part B/ SIMMERRING[®], sections 2.

Shaft:

Tolerance: ISO h11
Concentricity: IT 8
Roughness: Ra=0.2-0.8 μm
Rz=1-4 μm
Rmax=6 μm
Hardness: 45-60 HRC
Roughness: non oriented;
preferably by plunge grinding

Housing:

Tolerance: ISO H8
Roughness: Rmax<25 μm

Pressure diagram

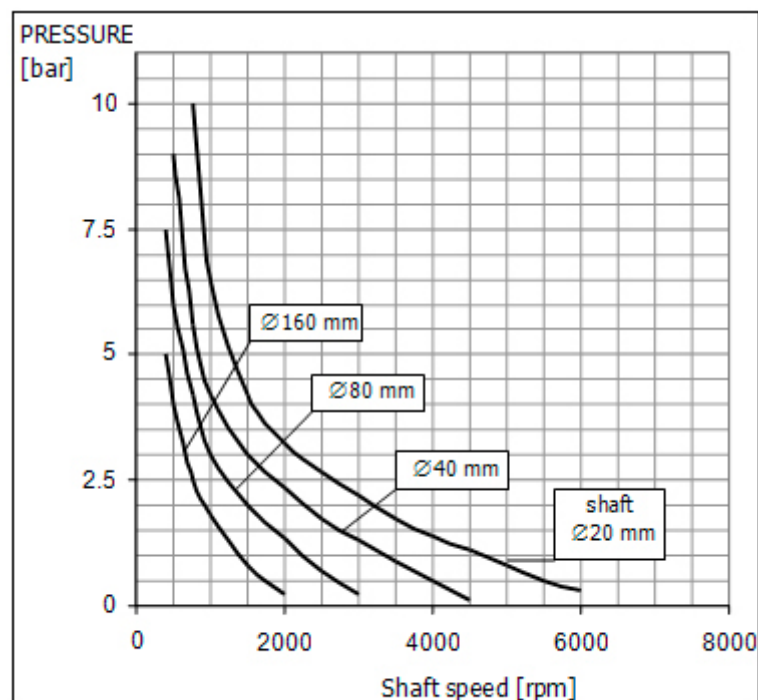

Diagram 1: Pressure Loading Limits

**Special seals for 15-20 bar continuous case pressure are available upon request (ordering code: HPS).
Refer to page 25 for more information.**

FORMULAS - CONVERSIONS

LEGEND		FORMULA	
T	Torque [Nm]	$T = T_s * P_r = (V * P_r) / 62.8$	
T_s	Specific torque [Nm/bar]	$P_1 = (T * S) / 9549$	
P₁	Power [kW]	$P_2 = (T * S) / 7023$	
P₂	Power [CV]	$S = (F * 1000) / V$	
S	Speed [rpm]	$V = (T * 62.8) / P_r$	
V	Displacement [cc/Rev]	$F = (V * S) / 1000$	
F	Flow [l/min]		
P_r	Pressure [bar]		
LENGHT	1 m = 39,3701 in = 3,2808 ft = 1,0936 yd = 1000 mm	MASS	1 kg = 2,2046 lb
1 in	= 0,0833 ft = 25,4 mm	FORCE	1 N = 0,102 kgf = 0,2248 lbf
1 ft	= 0,3048 m = 0,3333 yd = 12 in	1 kgf	= 2,205 lbf = 9,806 N
1 yd	= 0,9144 m = 3 ft = 36 in	1 lbf	= 0,4536 kgf = 4,448 N
1 km	= 1000 m = 1093,6 yd = 0,6214 mile	PRESSURE	1 bar = 14,223 psi = 0,99 atm = 1,02 ata = 100000 Pa = 100 kPa = 0,1 MPa
1 mile	= 1,609 km = 1760 yd	1 psi	= 0,0703 bar
SPEED	1 m/s = 3,6 km/h = 2,237 mph = 3,2808 ft/s	FLOW	1 l/min = 0,264 gpm = 1000 cc/Rev 1 gpm = 3,785 l/min = 3785 cc/min 1 m ³ /s = 60000 l/min = 15852 gpm
1 km/h	= 0,2778 m/s = 0,6214 mph = 0,9113 ft/s		
1 mph	= 1,609 km/h = 0,447 m/s = 1,467 ft/s		
1 ft/s	= 0,3048 m/s = 1,0973 km/h = 0,6818 mph		
POWER	1 kW = 1,341 HP = 1,3596 CV	VOLUME	1 m ³ = 1000 l 1 l = 61,023 in ³ = 0,264 galUS 1 in ³ = 0,01639 l = 16,39 cm ³ = 0,004326 galUS 1 galUS = 3,7879 l = 231,15 in ³
1 HP	= 0,7457 kW = 1,0139 CV	TORQUE	1 Nm = 0,102 kgm = 0,7376 lbf ft 1 kgm = 9,806 Nm = 7,2325 lbf ft 1 lbf ft = 0,1383 kgm = 1,3558 Nm

The data specified into the catalogue are for product description purpose only and must not be interpreted as warranted characteristics in legal sense. Italgroupp S.r.l. reserves the right to implement modifications without notice. All partial or total reproduction and copy without written authorization of Italgroupp S.r.l. is strictly forbidden.

The data specified into the catalogue are for product description purpose only and must not be interpreted as warranted characteristics in legal sense. ItalgrouP S.r.l. reserves the right to implement modifications without notice. All partial or total reproduction and copy without written authorization of ItalgrouP S.r.l. is strictly forbidden.

Motor installation

*The motor must be installed using the correct screws size (we recommends the use of 10.9 and 12.9 class resistance fixing screws) and must be placed on a structure that is capable to correctly support the motor during functioning: for this reason the structure must not only be able to support the motor weight but must also assure the absence of vibration during operation and must win the reaction forces that are generated by the working torque. Regarding the motor fitting design, the concentricity between the centering diameter (spigot) and shaft (both splined or parallel) must be assured with a strict tolerance (please refer to the following general indication). **If the concentricity between the shaft and the centering diameter and/or fixing holes is not respected, in the worst case the motor can have an unusual failure or can work only with low performances.** Splined adaptors (sleeves) are available upon request.*

Hoses and piping must be clean and free from contamination. Use proper hoses for oil connection, both for inlet and outlet main ports, displacement change ports, and for drain line. Refer to hoses and fitting constructors in order to correctly size and select hoses and fittings. In order to keep control on the oil compressibility keep hoses to the minimum recommended size and select pipelines most rigid as possible.

The motor can be mounted in any position (refer also to drain recommendations section). In run-away conditions you must use counterbalance valves. When the motor is installed vertically with shaft pointing upwards, consult our technical department. If the motor is connected to high inertial loads, the hydraulic system must be designed to prevent peaks of pressure and cavitation.

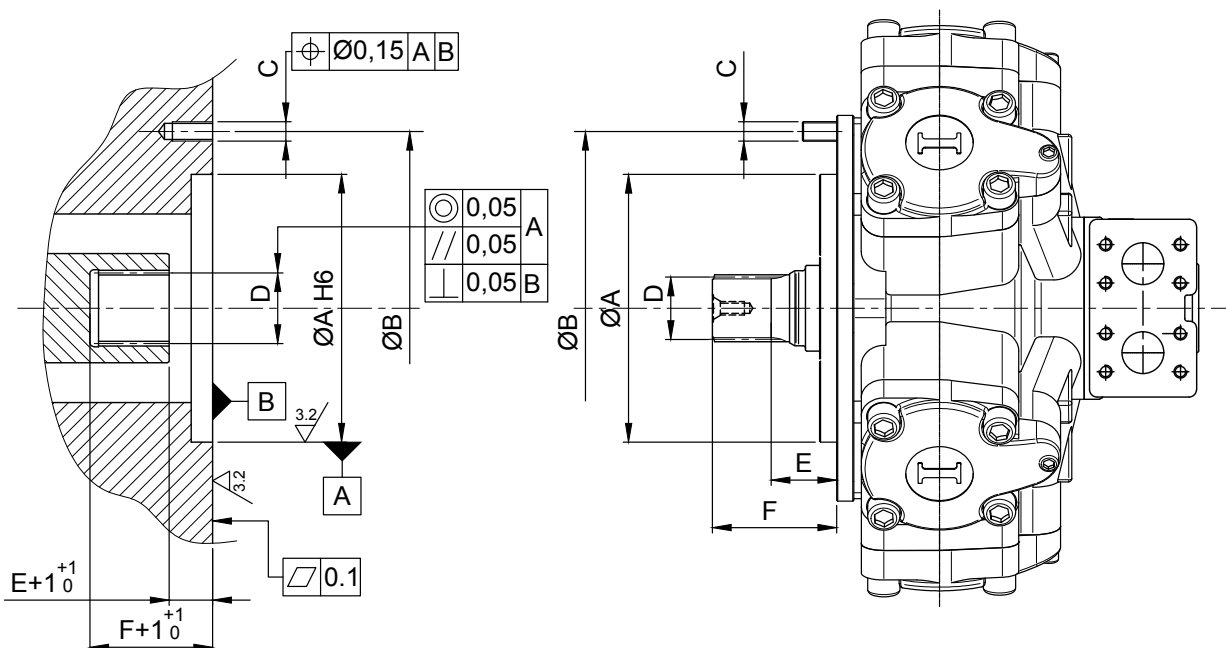

The data specified into the catalogue are for product description purpose only and must not be interpreted as warranted characteristics in legal sense. Italgrou S.r.l. reserves the right to implement modifications without notice. All partial or total reproduction and copy without written authorization of Italgrou S.r.l. is strictly forbidden.

Consider the use of relief valves, possibly directly mounted on motor distributor in case the application can generate pressure peaks at the motor ports: the relief valve should be able to discharge all the flow (or at least a good part of it) with a limited pressure increase. Italgroup can provide different valve types that can be placed directly on the motor distributor (please refer to Italgroup valves technical catalogue).

Motor case and pistons must be completely filled with oil before starting.

Do not load motor to maximum working pressure instantly. During cold start-up avoid high-speed operation until the system reaches the working temperature. Connect the case drain directly to tank, and avoid excessive drain line pressure losses (the case drain pressure must not exceed 6 bar continuous pressure for IAC series standard motors, contact Italgroup if higher motorcase pressure is needed). ***The case drain port on the motor must be located on the highest point of the installation to ensure that the motor will always be full of oil.*** (See drain recommendations page for more details)

Maximum oil temperature must not exceed 70°C. Heat exchangers must be used with higher temperatures. The operating fluid viscosity must always be higher than a certain minimum value (see “fluid recommendation” section) in order to guarantee an optimal motor internal lubrication. When the working conditions cause the motor case overheating above a critical value, the motor flushing is required. Flushing consists in the introduction of fresh oil (taken from the hydraulic circuit) into the motor case. Oil must be taken from the return line to avoid internal motor damage (for standard motors the continuous motor case pressure must be maximum 10 bar). Flushing is an important operation that can be very effective to improve motor lifetime with heavy duty working conditions and improve the motor mechanical efficiency.

The motor flushing, if the motor works in one direction only, can be easily performed connecting the motor return line to the lowest motor drain port. The highest motor drain port must be connected to the tank. For D75 and D90 flow distributors, the side 1/4” metallic plugs can be used for flushing circuit installation: in fact the plug (corresponding to the return line port) can be removed and the connection between motor low pressure port and motor case can be correctly realized. If the motor axis is not horizontal and/or the motor works in bidirectional operation, please contact Italgroup technical department, that can assist you to advise how to perform the desired operation in the best way. Just for your reference, Italgroup can provide you flushing valves in order to perform an effective flushing circuit.

High pressure applications

In case of high pressure applications, a Nitemper treatment on cylinders or in the motor body is suggested to increase wear and tear resistance.

Back pressure

Back pressure limit for IAC series motors is 70-80 bar (back pressure occurs for example when hydraulic motors are installed in series circuit). High back pressure values are often responsible of motor overheating, so if drain temperature reaches values that bring the oil viscosity under the recommended limit (refer to fluid recommendations section), perform appropriate motor flushing and/or reduce the back pressure.

Boost pressure

When the motor runs at a speed that can cause pumping effects, a positive pressure it is needed at the motor ports. The minimum required pressure at the motor ports can be estimated basing on different parameters, using the following formula:

$$p = 1 + p_c + C_H n^2 V^2$$

Where p is the boost pressure, p_c the case pressure, n the rotation speed, V the motor displacement, and C_H is a constant, depending by the motor serie.

Motor	C _H
IAC H1	0,25 * 10 ⁻⁹
IAC H3	0,25 * 10 ⁻⁹
IAC H4	0,5 * 10 ⁻¹⁰
IAC H5	0,5 * 10 ⁻¹⁰
IAC H6	0,4 * 10 ⁻¹⁰
IAC H7	0,25 * 10 ⁻¹⁰

Example:

We suppose (IAC H4 motor): n=400 [rpm], p_c=3 [bar], V=800 [cm³];

We can calculate the boost pressure as follows:

$$p = 1 + 3 + 0,5 * 10^{-10} * 400^2 * 800^2 = 1 + 3 + 5,12 = 9,12 \text{ [bar]}$$

Displacement change

The displacement change can be performed in different ways. The user can use an internal or esternal pilot. In addition Italgroupp can supply a Cetop 3 fitting with or without Cetop 3 displacement change valve (with electric or hydraulic control).

When the displacement change ports are not feeded with pressure, the motor remains at the maximum displacement: to perform the displacement change, the pilot pressure must be at least 2/3 of the motor working pressure.
A minimum pressure of around 3,5 bar (the value is approximate and can have variations in function of the operating parameters) is needed in order to activate the displacement change mechanism.

Please note that in freewheeling operation it is necessary supply the displacement control mechanism with an external supply pressure/flow source. This external supply source will assure that the motor displacement during the freewheeling operation remains fixed at the minimum value, avoiding IAC motor damage.

The oil flow rate required to perform the displacement change can be estimated in function of many different parameters; the most important factor that determinate the required flow rate is the motor case internal leakage. The flow rate that is shown in the next table must be considered as an indicative value that depends by many system parameters and working conditions.

The data specified into the catalogue are for product description purpose only and must not be interpreted as warranted characteristics in legal sense. Italgroupp S.r.l. reserves the right to implement modifications without notice. All partial or total reproduction and copy without written authorization of Italgroupp S.r.l. is strictly forbidden.

Motor	Required flow	Displacement change delay
IAC H1	8 l/min	0,2 s
IAC H3	12 l/min	0,2 s
IAC H4	15 l/min	0,25 s
IAC H5	15 l/min	0,5 s
IAC H6	15 l/min	0,5 s
IAC H7	20 l/min	1 s

The system components (pumps, motors...) present tear and wear phenomena that are clearly variables during the system life, so the required flow rate is variable during the motor life, this variation is very difficult to estimate: for this reason the values reported must be considered as approximated and indicative values.

Minimum speed

Minimum speed is very low and can reach values near to 1-2 rpm (depending on motor displacement). In case of low speed vibration a reasonable back pressure can eliminate or minimize the vibration and noise level (a general guideline value can be defined by 5-8 bar back pressure). For more information please contact our technical department.

Displacement change port configuration

“XY” code

“XY” displacement change port configuration:

when Y port is connected to the supply source (refer to displacement change section) the maximum displacement is activated.

When the X port is connected to the supply source, the minimum displacement is activated.

Please refer to the “displacement change hydraulic circuit” section for more details.

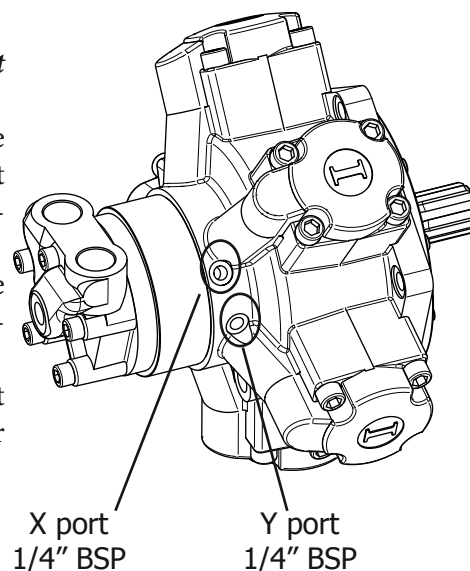

Displacement change port configuration

(continue from previous page)

“C3-SV” displacement change port configuration:

there is a cetop 3 standard fitting that can be used to fit a cetop 3 displacement change valve (solenoid or hydraulic operated).

In addition a shuttle valve SV is integrated inside the motor distributor.

Please refer to the “displacement change hydraulic circuit” section for more details.

Pilot supply source port

“C3-SV” code

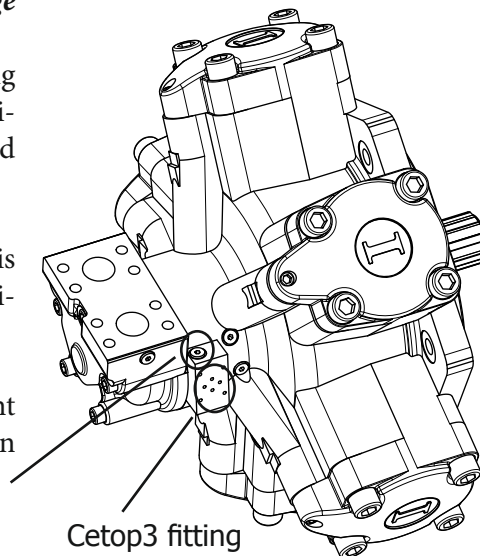

“C3-XX SV” code

“C3-12 SV” displacement change port configuration:

the displacement change valve is solenoid operated, 12 V DC.

“C3-24 SV” displacement change port configuration:

the displacement change valve is solenoid operated, 24 V DC.

“C3-HY SV” displacement change port configuration:

the displacement change valve is hydraulic operated.

Please refer to the “displacement change hydraulic circuit” section for more details.

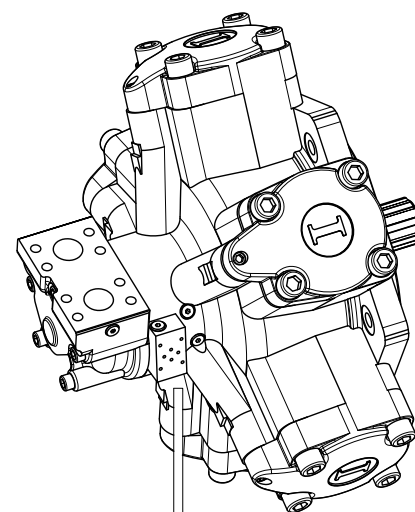

C3-12 SV

C3-24 SV

C3-HY SV

Basic displacement change hydraulic circuits

In all circuits, A and B identify the motor inlet/outlet port (the motor is fully reversible, can work with same behavior in both directions), whereas L identify the motor drain port.

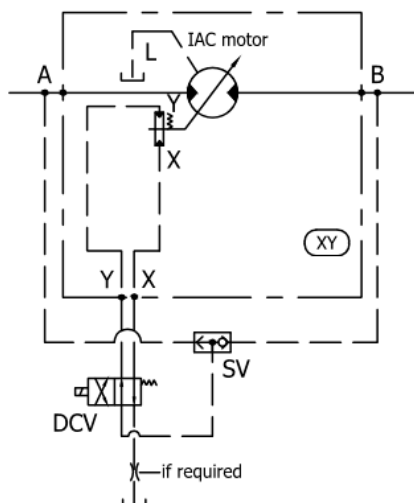

The typical displacement change circuit is shown on the left; the displacement change pressure is taken from the higher pressure motor port (if motor works in a bidirectional way a shuttle valve, SV, is needed to make the selection between the higher and lower pressure port). To order the shown motor assembly the ordering code is "XY" (the displacement change port fittings are 1/4" BSP female thread).

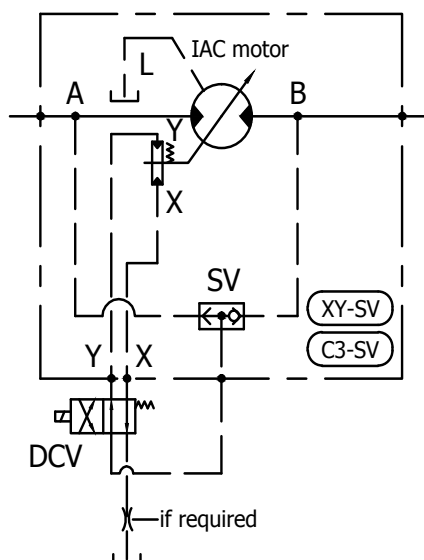

ItalgrouP can provide a special motor distributor with integrated shuttle valve (SV). The ordering code is "XY-SV" for displacement change fitting 1/4" BSP (female threads) or "C3-SV" for cetop 3 displacement change valve fitting.

Italgrou can supply solenoid or hydraulic operated displacement change valves, directly fitted on the motor (please refer to ordering code section and dimensional drawings for more information). The circuit on the right shows a complete assembly with displacement change valve and shuttle valve, included in the motor assembly. The ordering code in this case is “C3-12 SV” or “C3-24 SV”, in case the DCV is solenoid operated, or “C3-HY SV” if is hydraulic operated.

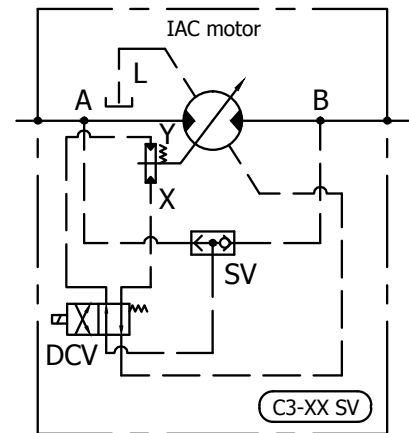

Advanced displacement change hydraulic circuits (with external supply source)

When the working pressure can reach very low values, lower than the minimum pressure that is required for displacement change (approximately 3,5 bar in normal conditions), an external displacement change pilot supply source is required. Please refer to the circuit on the right.

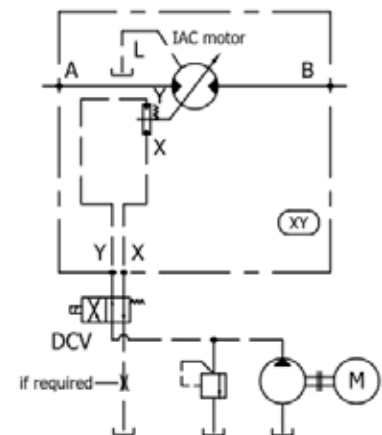

The circuit on the right shows an integrated SV valve with external pilot supply: when the motor working pressure is lower than the external supply relief valve setting, the displacement change pressure is taken from the external supply source. When motor working pressure is higher than the external supply relief valve setting the displacement change pressure is taken from the motor ports. The circuit refer to the “XY” displacement change port configuration.

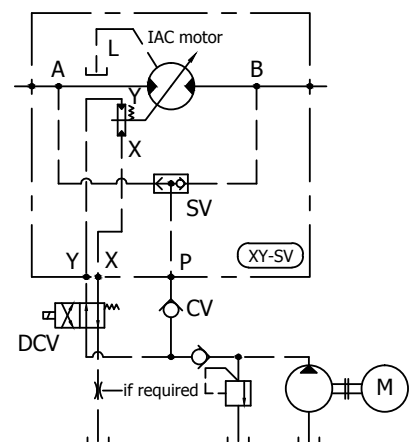

The data specified into the catalogue are for product description purpose only and must not be interpreted as warranted characteristics in legal sense. Italgrou S.r.l. reserves the right to implement modifications without notice. All partial or total reproduction and copy without written authorization of Italgrou S.r.l. is strictly forbidden.

Displacement change hydraulic circuit

(continue from previous page)

The complete assembly with motor, displacement change valve DCV and integrated shuttle valve SV can be equipped with an external pressure supply source. Please refer to the circuit shown on the right. The ordering code in this case is "C3-12 CSV" or "C3-24 CSV" in case the displacement change valve is solenoid operated, or "C3-HY CSV" in case the displacement change valve is hydraulic operated (please refer to ordering code section and dimensional drawings for more information).

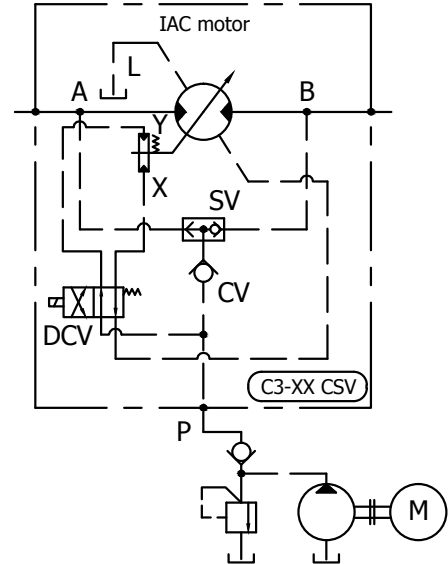

Small displacement / freewheeling circuit

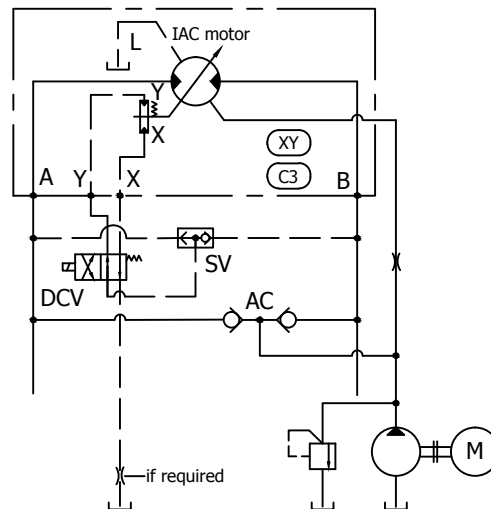

Selecting a zero displacement IAC motor, the motor can run without load at high speed, resulting in a minimum motor torque requirement. The maximum working pressure shown in the motor technical data or the zero displacement code are relative to a 1000 rpm shaft speed.

If the output shaft speed is less than 1000 rpm the maximum working pressure can be slightly increased. Consult ItalgrouP technical department to obtain more details. For output shaft speed higher than 1000 rpm the application duty cycle must be considered by ItalgrouP. When the motor is running at high speed, a minimum pressure must exist at the motor ports (see boost pressure paragraph), but in all cases this pressure must not exceed the maximum working pressure reported in the zero displacement code motor technical data.

To perform the boost circuit, an anticavitation valve (AC valve, referring to the diagram on the previous page) must be present, in order to avoid cavitation.

A crankcase flushing flow is highly recommended in freewheeling operation, to control and reduce the motor temperature rise during the freewheeling. If the motor running speed is between 1000 and 1500 rpm, a 15 l/min (indicative value) flushing flow is compulsory.

Bearings

The bearing life depends by different factors, like bearing type, motor speed, working pressure, external loads, duty cycle, fluid viscosity, oil cleanliness, type and temperature.

Lifetime is measured by L_{10} which is called “theoretic lifetime”. It represents the number of cycles that 90% of identical bearings can effort at the same load without showing wear and tear.

Please refer to bearing lifetime diagrams reported in the following pages to obtain the theoretical bearing lifetime. *The lifetimes diagrams shown the L_{50} median or average lifetime, that can be considered as 5 times L_{10} .*

Please note that the theoretical lifetime can be different from the real lifetime, especially in case of heavy duty applications with continuous work cycle. Please contact Italgroupp S.r.l. for more information.

Motor creep speed

The hydraulic motor is able to hold the load acting as a brake (if proper valves or circuit are considered and installed), but a certain creep speed is always present: this is typical of all brands hydraulic motors.

The motor creep speed depends by many factors, like operating conditions (motor displacement and type, pressure load on the shaft, oil viscosity, type and temperature) and are represented in the creep speed diagrams (see performance diagrams for each motor size). *The creep speed diagrams are shown for an hydraulic oil at reference conditions of 40 cSt.*

If creep speed is higher than desired value a negative brake can be considered: Italgroupp can supply negative brakes that can be fitted to the hydraulic motor. Please contact Italgroupp S.r.l. for more information.

Special features

Marine painting

If needed, special painting or primers are available in order to guarantee optimal protection against normal corrosion and marine environment corrosion. The ordering code is MP. Please contact ItalgrouP S.r.l. for more information.

Speedy-sleeve

A special inox sleeve is available upon request. In case the motor is used in aggressive medias or environments, this can be very useful in order to protect the motor shaft surface located in proximity of the motor shaft seal. This improves the shaft and seal endurance respect to wear and corrosion. The ordering code is SPSL. Please contact ItalgrouP S.r.l. for more information.

High pressure shaft seal

Standard IAC motors are supplied with high pressure shaft seals, the continuous drain pressure must be maximum 10 bar, whereas the peak drain pressure must be maximum 15 bar. In case the drain line can or must has a higher pressure, special shaft seals are available upon request. The ordering code is HPS. The drain pressure with HPS shaft seal can reach 20-25 bar continuous pressure and 30 bar peak pressure. The HPS shaft seal is bi-directional also, so it can be used for example in underwater applications. Please contact ItalgrouP S.r.l. for more information.

Counterclockwise rotation

Standard IAC motors are supplied with *clockwise* distributor timing. Please refer to the installation drawings of each section for more information. With ordering code CCW the motor is supplied with *counterclockwise* rotation timing. Contact ItalgrouP for more information.

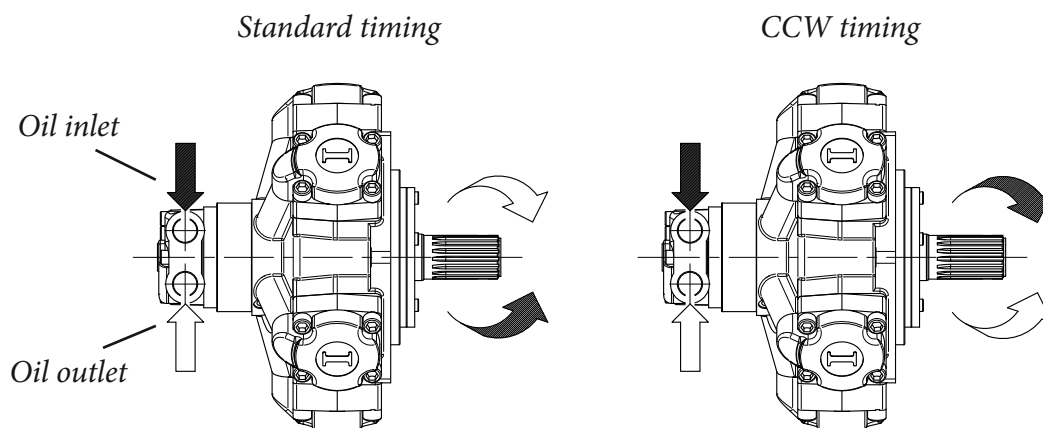

The data specified into the catalogue are for product description purpose only and must not be interpreted as warranted characteristics in legal sense. Italgroupp S.r.l. reserves the right to implement modifications without notice. All partial or total reproduction and copy without written authorization of Italgroupp S.r.l. is strictly forbidden.

ITALGROUP SRL
IAC SERIES - IAC H1
GENERAL CATALOGUE

INDEX - IAC H1

TECHNICAL DATA	Pag	36
IAC 195-250 H1 - INSTALLATION DRAWING	“	37
IAC 195/S-250/S H1 - INSTALLATION DRAWING	“	38
IAC 195/BH-250/BH H1 - INSTALLATION DRAWING	“	39
IAC H1 - NIP OPTION	“	40
IAC H1 - CETOP 3 FITTING	“	41
IAC H1 - ORDERING CODE	“	42
IAC 195 H1 - PERFORMANCE DIAGRAMS	“	44 - 45
IAC 250 H1 - PERFORMANCE DIAGRAMS	“	46 - 47

IAC 195 H1

Displacement (*)	[cc]	195	175	150	125	100	95	75	69
Th. specific torque	[Nm/bar]	3,1	2,8	2,4	2	1,6	1,5	1,2	1,1
Continuous speed	[rpm]	850	850	1000	1000	1050	1050	1100	1100
Peak speed	[rpm]	950	1050	1150	1150	1200	1200	1250	1250
Minimum speed	[rpm]	3	3	3	4	4	4	5	5
Mechanical efficiency	[%]	89,5	89,2	89	88,5	88	87,8	87	85,5
Starting efficiency	[%]	84,5	84,2	84	83,5	83	82	80	77
Continuous power (**)	[kW]	36	34	32	30	28	26	20	18
Cont. power with flushing	[kW]	45	42	38	36	35	32	26	24
Continuous pressure	[bar]	270	270	270	270	250	250	250	250
Intermittent pressure	[bar]	310	310	310	310	310	310	310	310
Peak pressure	[bar]	350	350	350	350	350	350	350	350
Flushing flow	[l/min]	6	6	6	6	6	6	6	6
Dry weight	[kg]	26	26	26	26	26	26	26	26

IAC 250 H1

Displacement (*)	[cc]	257	232	195	175	150	125	100	95
Th. specific torque	[Nm/bar]	4,1	3,7	3,1	2,8	2,4	2	1,6	1,5
Continuous speed	[rpm]	810	810	850	850	1000	1000	1050	1050
Peak speed	[rpm]	920	920	950	1050	1150	1150	1200	1200
Minimum speed	[rpm]	3	3	3	3	3	4	4	5
Mechanical efficiency	[%]	88,5	88,2	88	87,5	87	86,8	86	84,5
Starting efficiency	[%]	83,5	83,2	83	82,5	82	81	79	76
Continuous power (**)	[kW]	38	37	36	34	32	30	28	28
Cont. power with flushing	[kW]	48	46	45	43	40	38	34	32
Continuous pressure	[bar]	250	250	250	250	250	250	250	250
Intermittent pressure	[bar]	310	310	310	310	310	310	310	310
Peak pressure	[bar]	350	350	350	350	350	350	350	350
Flushing flow	[l/min]	6	6	6	6	6	6	6	6
Dry weight	[kg]	26	26	26	26	26	26	26	26

(*) Different displacements can be available on request. Please contact ItalgrouP S.r.l. for more information.

(**) The continuous power and the continuous power with flushing are the output maximum power. To estimate the input power divide the output power by the mechanical efficiency. For example: if required output power is 40 kW and starting efficiency is 90%, estimated required power is $40/0.9 = 44,44$ kW.

Hydrostatic pressure test: 420 bar.

Temperature range: -30 / 70 °C.

IAC 195-250 H1 - INSTALLATION DRAWING

XY DISPLACEMENT CHANGE CONFIGURATION

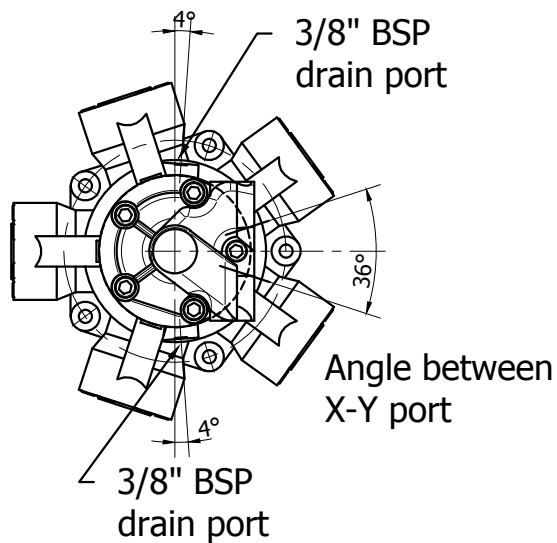
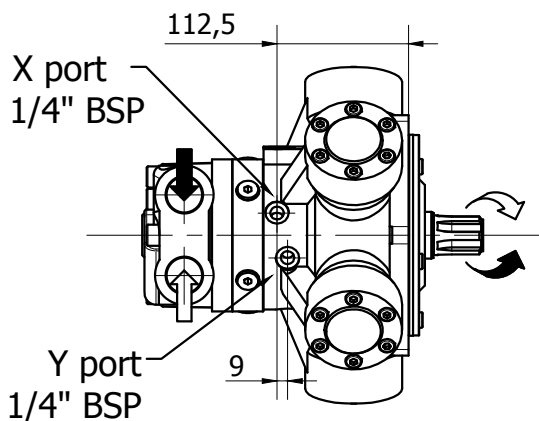
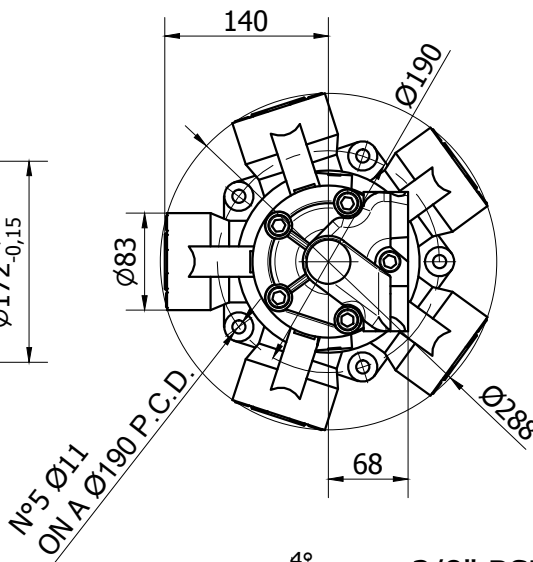
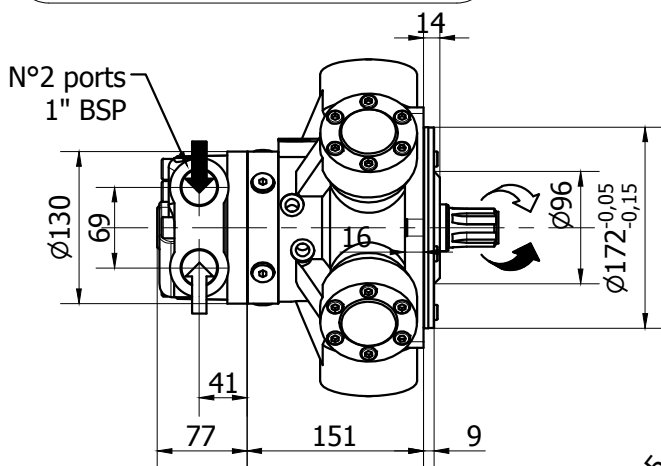

SHAFT TYPE: A0

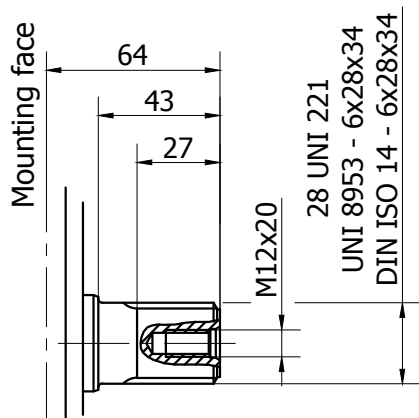

X - minimum displacement
Y - maximum displacement

The data specified into the catalogue are for product description purpose only and must not be interpreted as warranted characteristics in legal sense. Italgrou S.r.l. reserves the right to implement modifications without notice. All partial or total reproduction and copy without written authorization of Italgrou S.r.l. is strictly forbidden.

XY DISPLACEMENT CHANGE CONFIGURATION

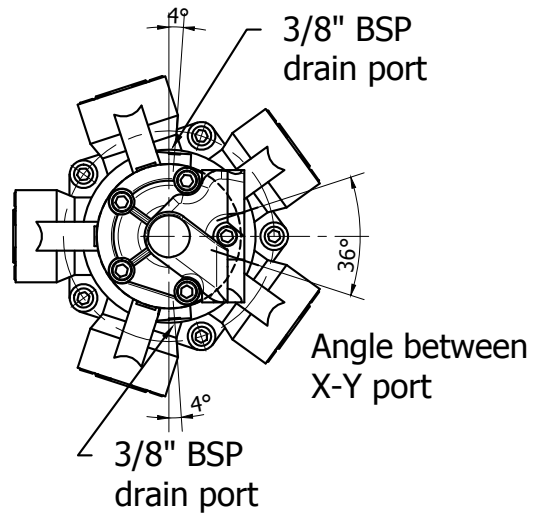
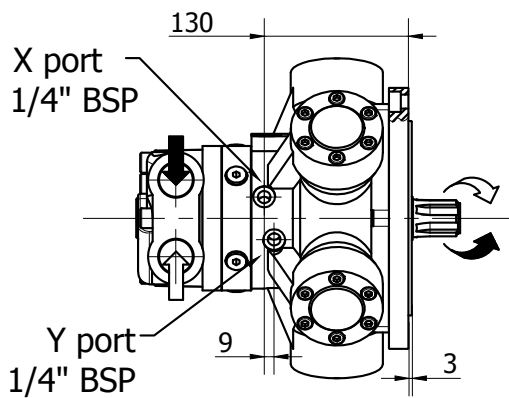
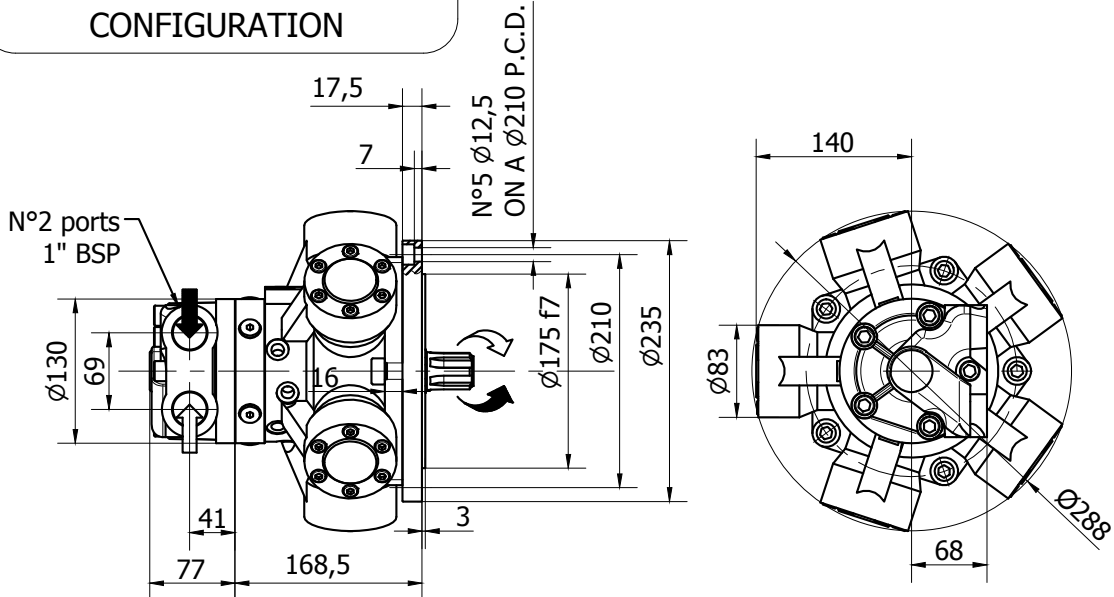

SHAFT TYPE: A0

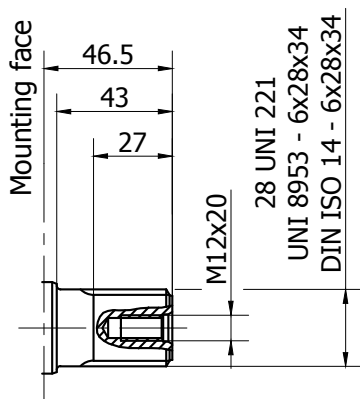

X - minimum displacement
 Y - maximum displacement

The data specified into the catalogue are for product description purpose only and must not be interpreted as warranted characteristics in legal sense. Italgrou S.r.l. reserves the right to implement modifications without notice. All partial or total reproduction and copy without written authorization of Italgrou S.r.l. is strictly forbidden.

XY DISPLACEMENT CHANGE
CONFIGURATION

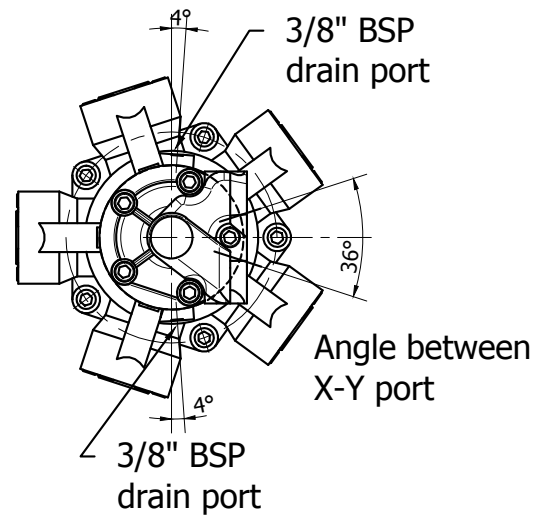
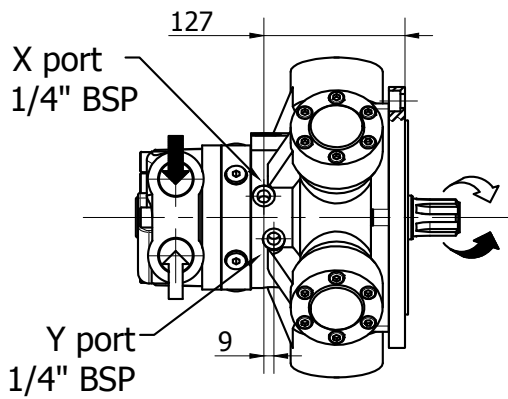
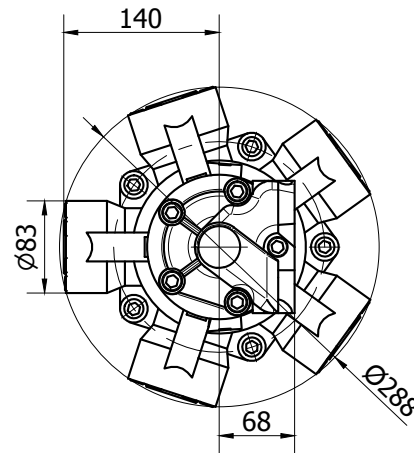
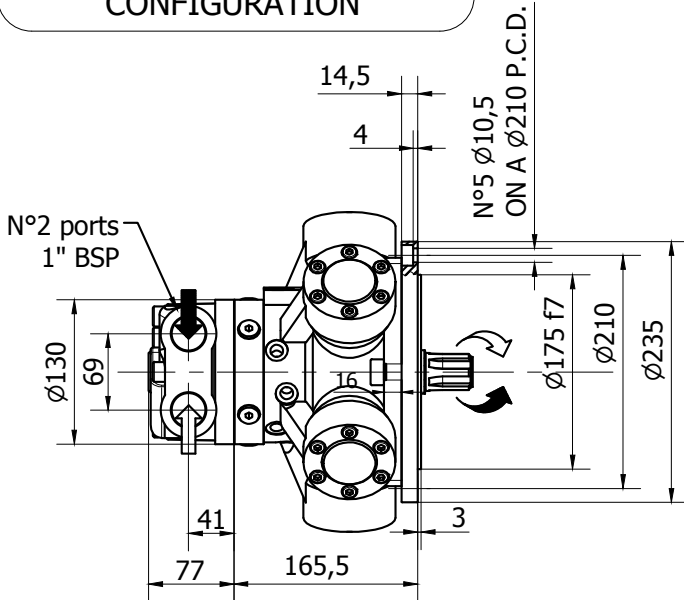

SHAFT TYPE: A0

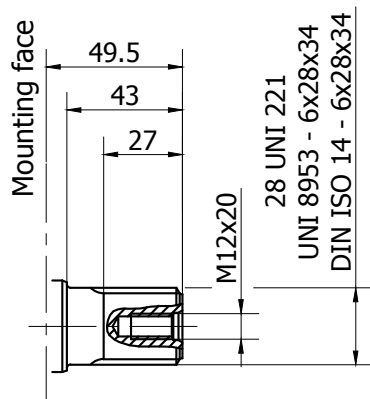

X - minimum displacement
Y - maximum displacement

**XY DISPLACEMENT CHANGE
CONFIGURATION**

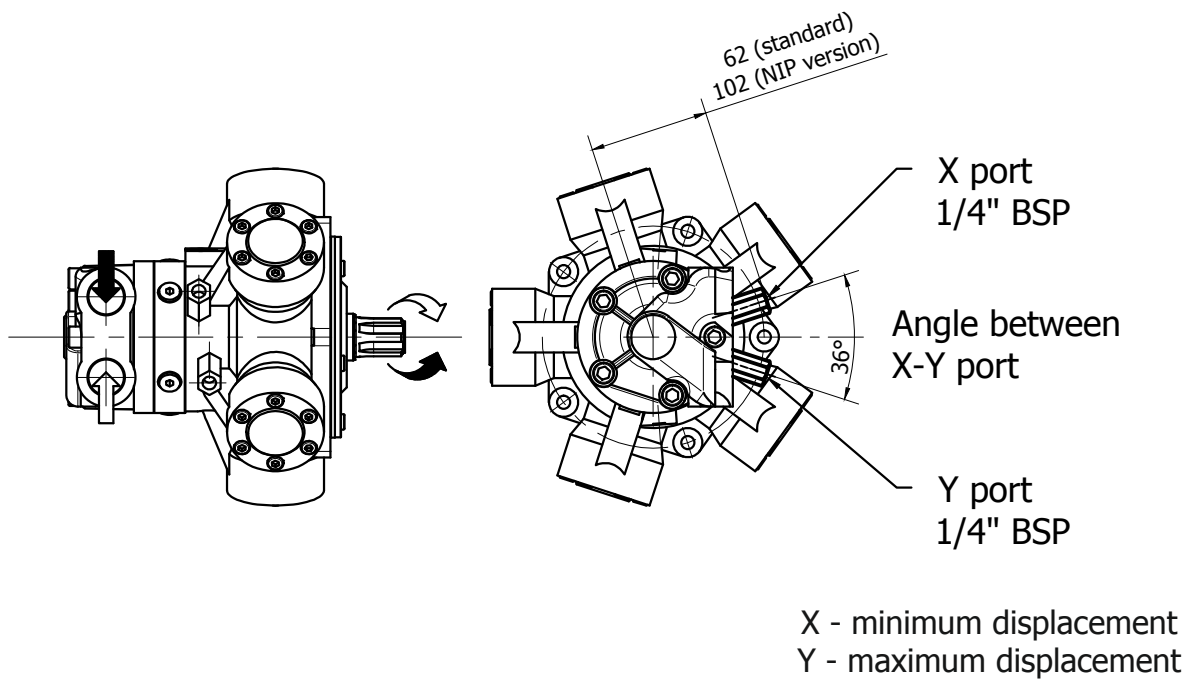

IAC H1 - CETOP 3 FITTING

CETOP 3 DISPLACEMENT CHANGE CONFIGURATION

X - minimum displacement
Y - maximum displacement

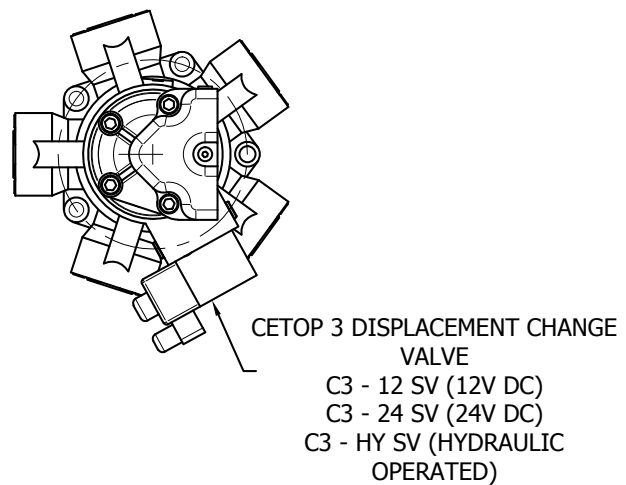
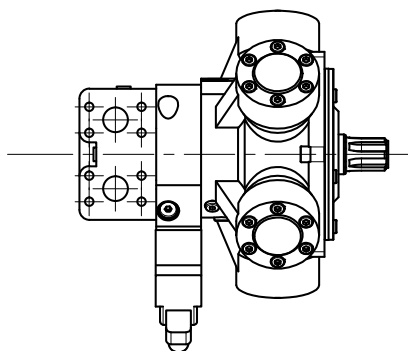
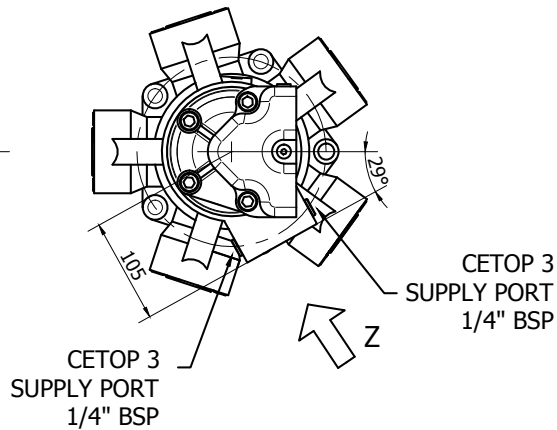
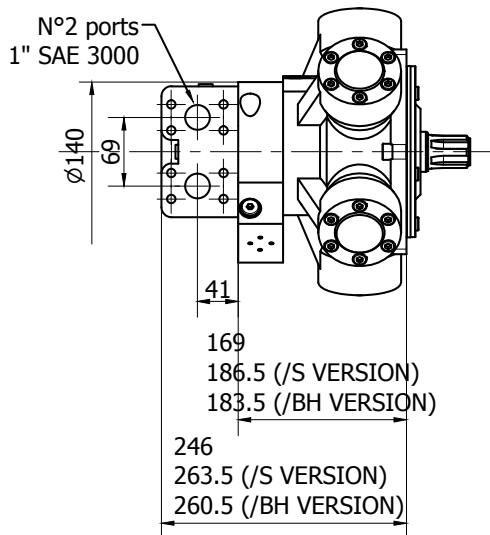
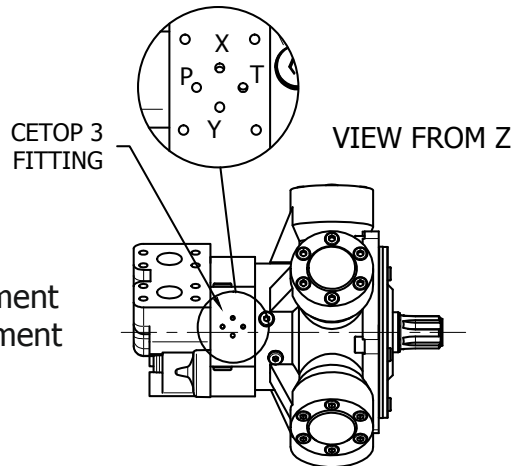

The data specified into the catalogue are for product description purpose only and must not be interpreted as warranted characteristics in legal sense. Italgroup S.r.l. reserves the right to implement modifications without notice. All partial or total reproduction and copy without written authorization of Italgroup S.r.l. is strictly forbidden.

IAC 195-250 H1 - ORDERING CODE

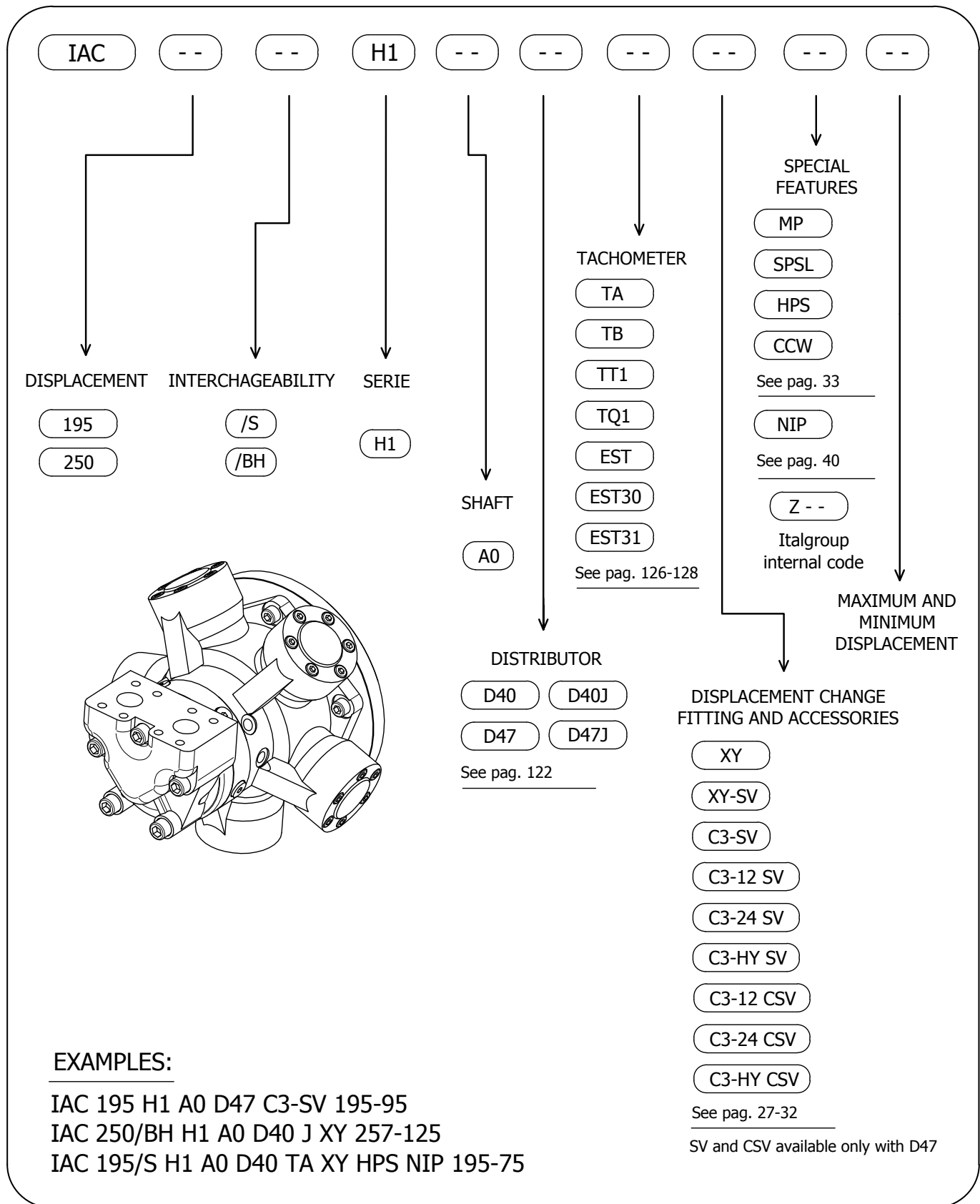

The data specified into the catalogue are for product description purpose only and must not be interpreted as warranted characteristics in legal sense. Italgrou S.r.l. reserves the right to implement modifications without notice. All partial or total reproduction and copy without written authorization of Italgrou S.r.l. is strictly forbidden.

195 cc - WITHOUT FLUSHING

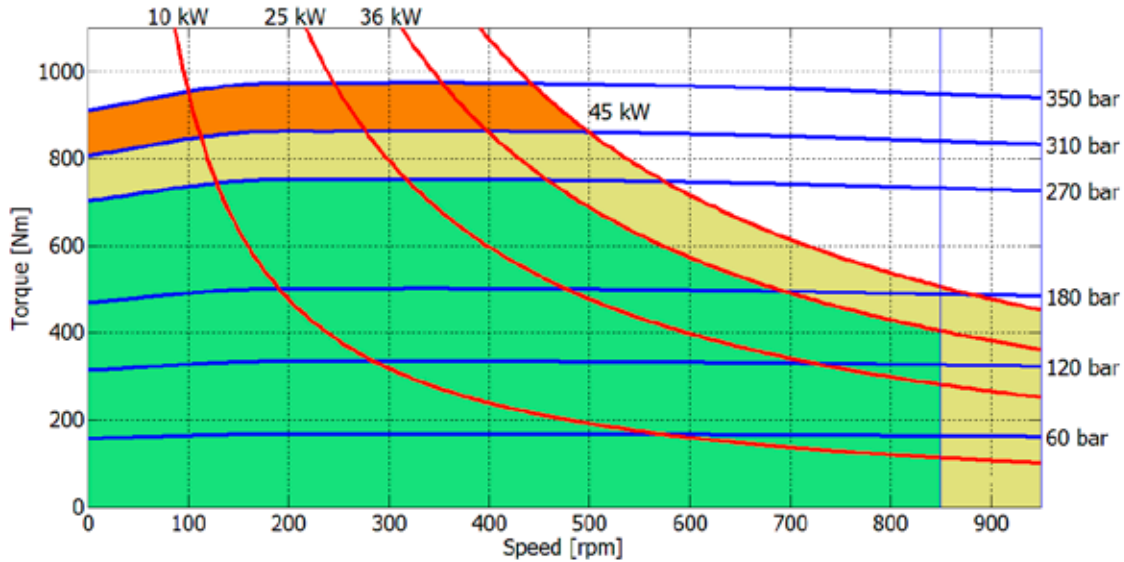

95 cc - WITHOUT FLUSHING

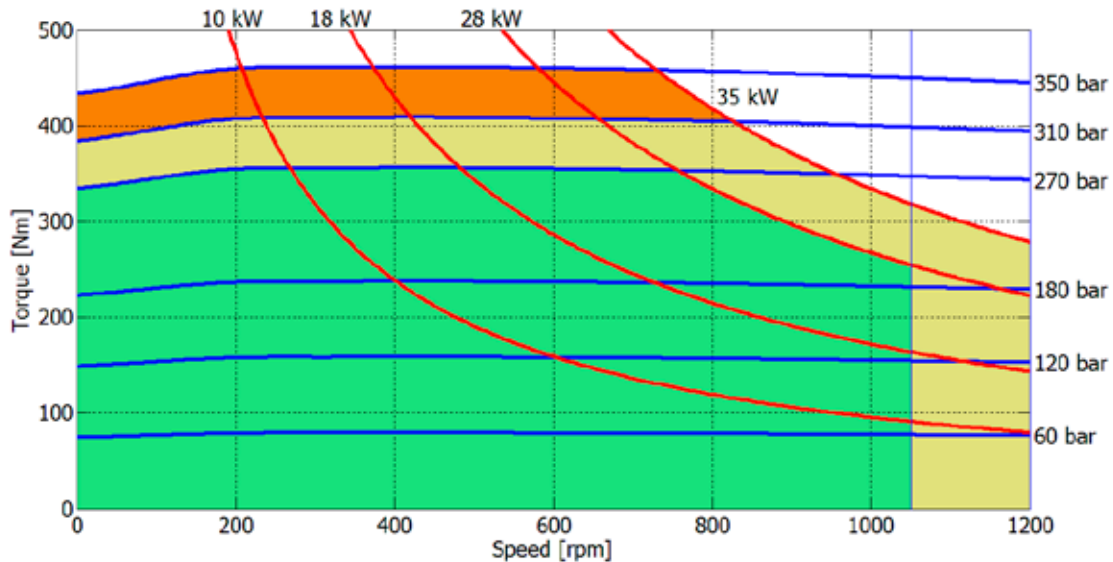

Continuous operation



Intermittent operation: permitted for a 15% of duty cycle, for 3 minutes maximum period.



Peak operation: permitted for very short periods (3-5 seconds every 10-15 minutes).

The above diagrams are referring to the hydraulic motor working with a fluid in ideal conditions (viscosity at 40 cSt). In case the working temperature increases and viscosity reach values under the recommended values (see hydraulic fluid recommendations) flushing must be performed or ISO oil grade must be changed. The working temperature must not overcome 70 °C.

The data specified into the catalogue are for product description purpose only and must not be interpreted as warranted characteristics in legal sense. ItalgrouP S.r.l. reserves the right to implement modifications without notice. All partial or total reproduction and copy without written authorization of ItalgrouP S.r.l. is strictly forbidden.

195 cc - WITH FLUSHING

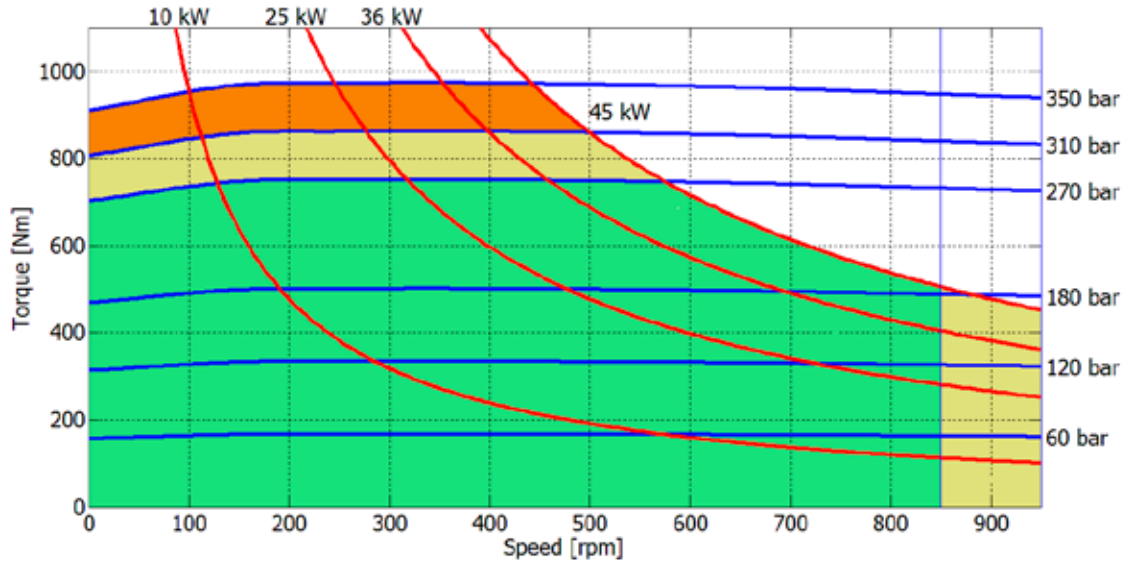

95 cc - WITH FLUSHING

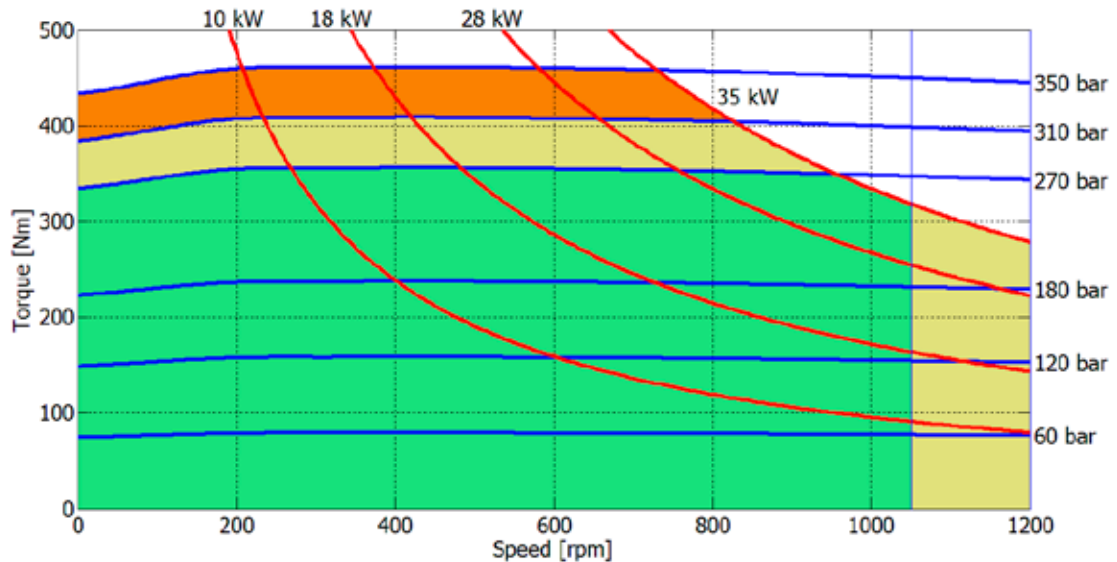

Continuous operation



Intermittent operation: permitted for a 15% of duty cycle, for 3 minutes maximum period.



Peak operation: permitted for very short periods (3-5 seconds every 10-15 minutes).

The above diagrams are referring to the hydraulic motor working with a fluid in ideal conditions (viscosity at 40 cSt). In case the working temperature increases and viscosity reach values under the recommended values (see hydraulic fluid recommendations) flushing must be optimized or ISO oil grade must be changed. The working temperature must not overcome 70 °C.

The data specified into the catalogue are for product description purpose only and must not be interpreted as warranted characteristics in legal sense. Italgrou S.r.l. reserves the right to implement modifications without notice. All partial or total reproduction and copy without written authorization of Italgrou S.r.l. is strictly forbidden.

CREEP SPEED - VOLUMETRIC EFFICIENCY

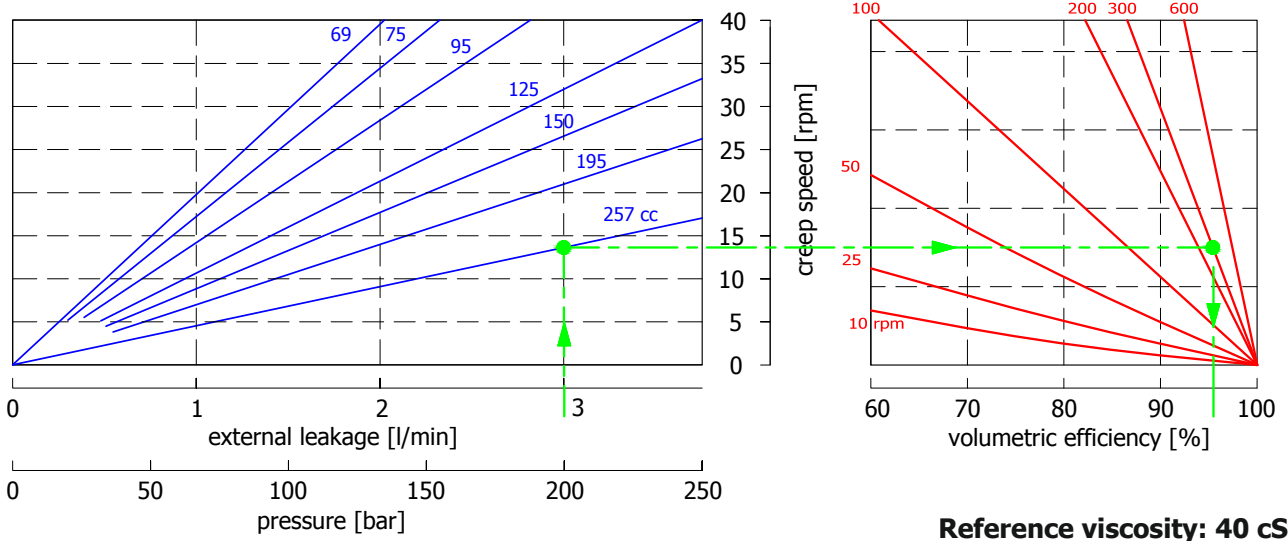

Example:

We suppose (257 cc): $p=200$ [bar], we obtain: external leakage 2,9 [l/min], shaft creep speed 13,5 [rpm].
 If we suppose (257 cc): $p=200$ [bar] and $n=300$ [rpm] we obtain a volumetric efficiency of 96%;

BEARING LIFE

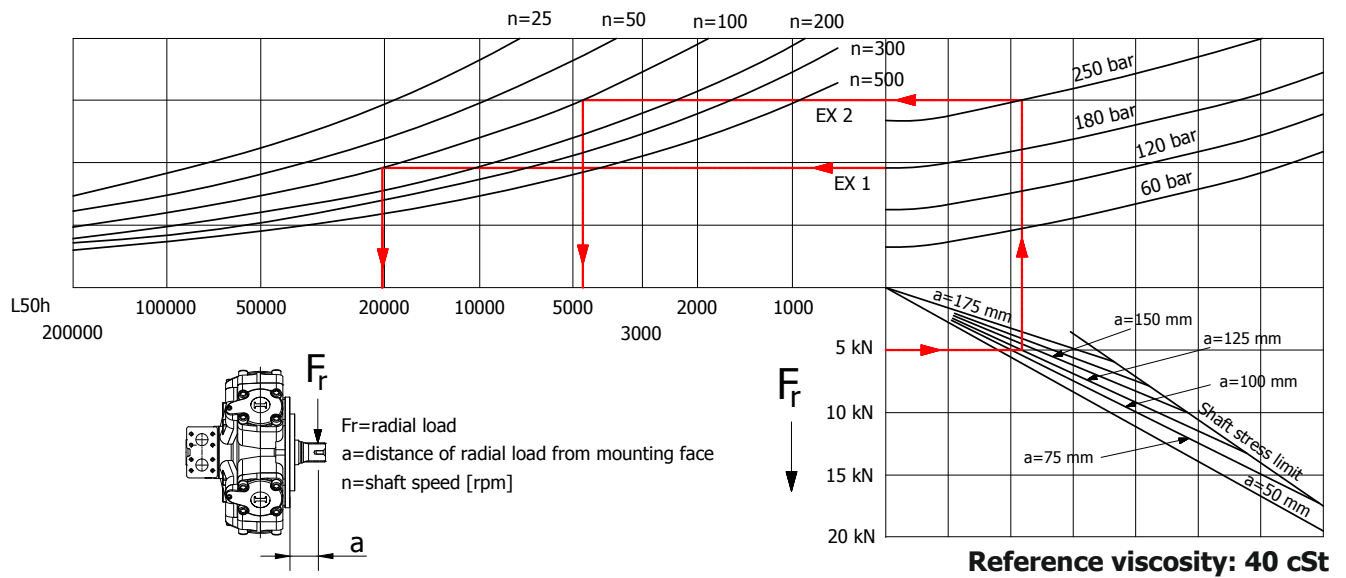

Example:

We suppose (EX1): $p=180$ [bar], $n=100$ [rpm]; we obtain an average lifetime of 20000 [h].

If we suppose (EX2): $F_r=5$ [kN], $a=125$ [mm], $p=250$ [bar] and $n=100$ [rpm], we obtain an average lifetime of 4500 [h].

The data specified into the catalogue are for product description purpose only and must not be interpreted as warranted characteristics in legal sense. ItalgrouP S.r.l. reserves the right to implement modifications without notice. All partial or total reproduction and copy without written authorization of ItalgrouP S.r.l. is strictly forbidden.

257 cc - WITHOUT FLUSHING

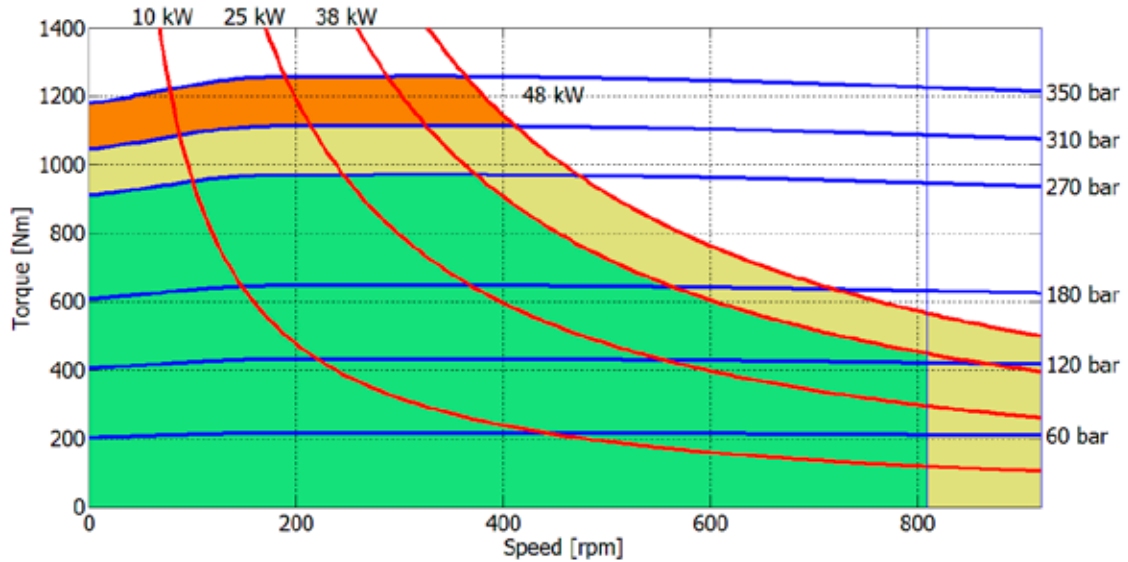

125 cc - WITHOUT FLUSHING

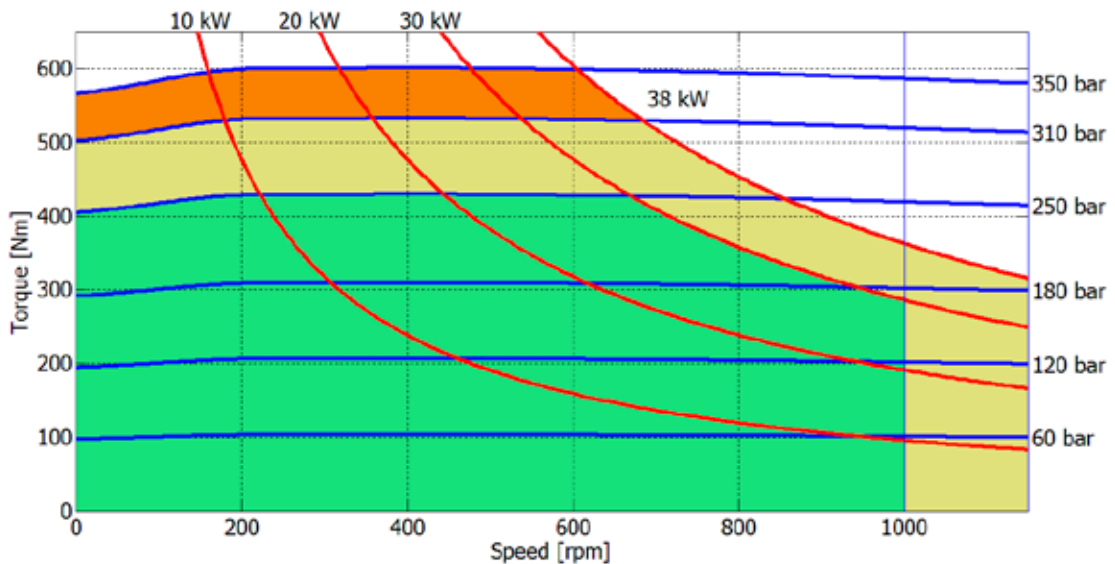

Continuous operation



Intermittent operation: permitted for a 15% of duty cycle, for 3 minutes maximum period.



Peak operation: permitted for very short periods (3-5 seconds every 10-15 minutes).

The above diagrams are referring to the hydraulic motor working with a fluid in ideal conditions (viscosity at 40 cSt). In case the working temperature increases and viscosity reach values under the recommended values (see hydraulic fluid recommendations) flushing must be performed or ISO oil grade must be changed. The working temperature must not overcome 70 °C.

The data specified into the catalogue are for product description purpose only and must not be interpreted as warranted characteristics in legal sense. Italgrou S.r.l. reserves the right to implement modifications without notice. All partial or total reproduction and copy without written authorization of Italgrou S.r.l. is strictly forbidden.

250 cc - WITH FLUSHING

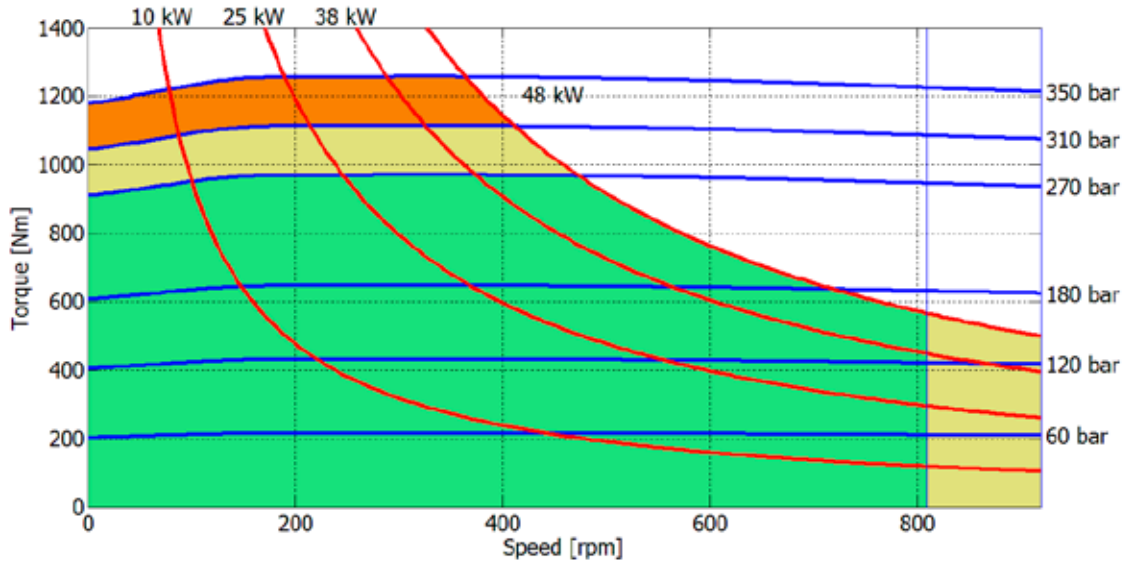

125 cc - WITH FLUSHING

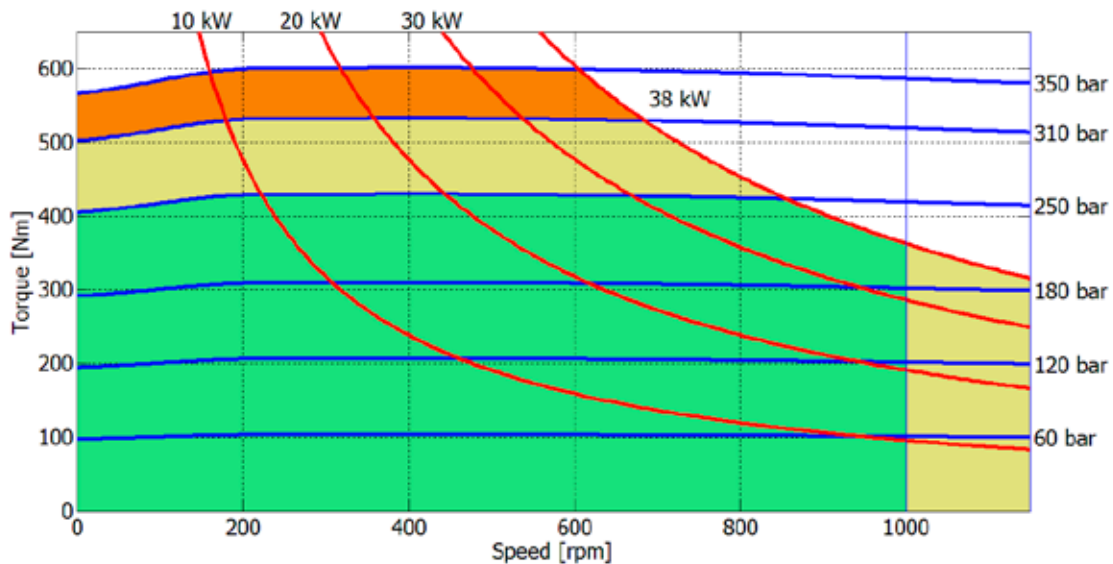

Continuous operation



Intermittent operation: permitted for a 15% of duty cycle, for 3 minutes maximum period.



Peak operation: permitted for very short periods (3-5 seconds every 10-15 minutes).

The above diagrams are referring to the hydraulic motor working with a fluid in ideal conditions (viscosity at 40 cSt). In case the working temperature increases and viscosity reach values under the recommended values (see hydraulic fluid recommendations) flushing must be optimized or ISO oil grade must be changed. The working temperature must not overcome 70 °C.

The data specified into the catalogue are for product description purpose only and must not be interpreted as warranted characteristics in legal sense. ItalgrouP S.r.l. reserves the right to implement modifications without notice. All partial or total reproduction and copy without written authorization of ItalgrouP S.r.l. is strictly forbidden.

CREEP SPEED - VOLUMETRIC EFFICIENCY

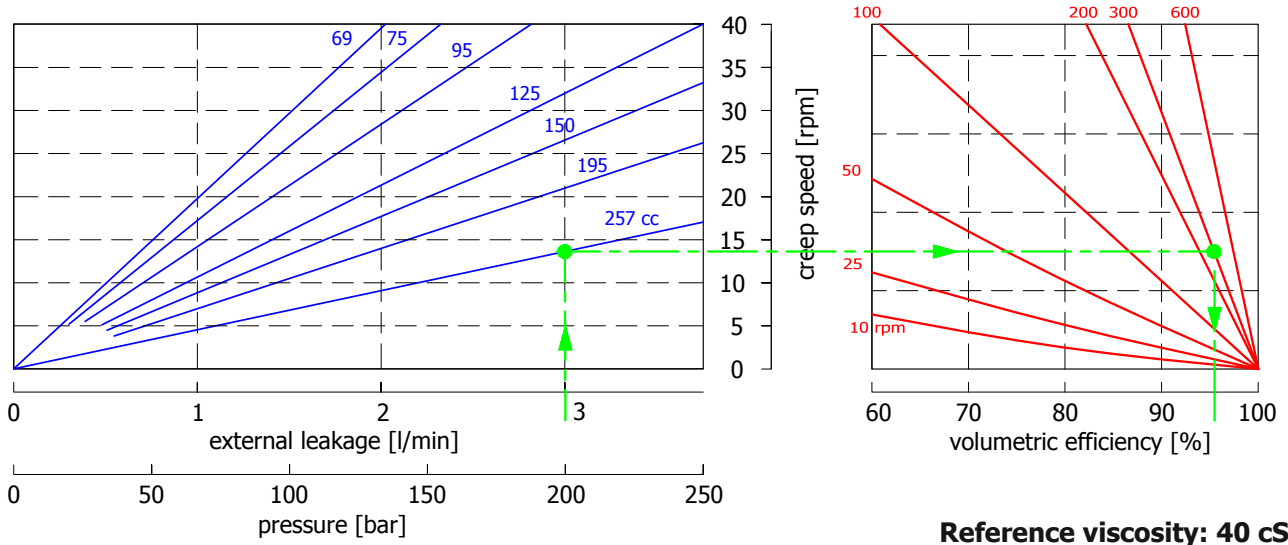

Example:

We suppose (257 cc): $p=200$ [bar], we obtain: external leakage 3 [l/min], shaft creep speed 13,5 [rpm].
If we suppose (257 cc): $p=200$ [bar] and $n=300$ [rpm] we obtain a volumetric efficiency of 96%;

BEARING LIFE

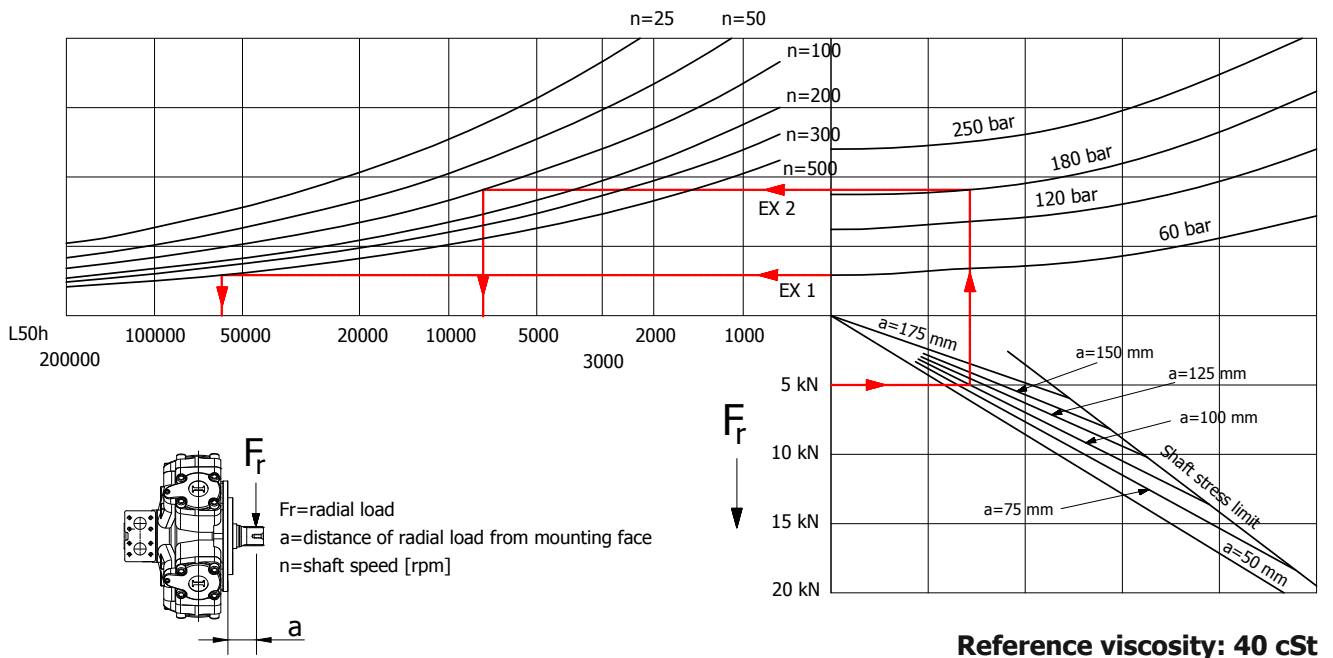

Example:

We suppose (EX1): $p=60$ [bar], $n=500$ [rpm]; we obtain an average lifetime of 55000 [h].
If we suppose (EX2): $F_r=5$ [kN], $a=100$ [mm], $p=180$ [bar] and $n=100$ [rpm], we obtain an average lifetime of 7500 [h].

The data specified into the catalogue are for product description purpose only and must not be interpreted as warranted characteristics in legal sense. Italgrou S.r.l. reserves the right to implement modifications without notice. All partial or total reproduction and copy without written authorization of Italgrou S.r.l. is strictly forbidden.

ITALGROUP SRL
IAC SERIES - IAC H3
GENERAL CATALOGUE

INDEX - IAC H3

TECHNICAL DATA	Pag	50
IAC 500 H3 - INSTALLATION DRAWING	“	51
IAC 500/B30 H3 - INSTALLATION DRAWING	“	52
IAC 500/C H3 - INSTALLATION DRAWING	“	53
IAC 500/MRH H3 - INSTALLATION DRAWING	“	54
IAC H3 - NIP OPTION	“	55
IAC H3 - CETOP 3 FITTING	“	56
IAC H3 - ORDERING CODE	“	57
IAC 500 H3 - PERFORMANCE DIAGRAMS	“	58 - 59

IAC 500 H3

Displacement (*)	[cc]	492	442	393	344	292
Th. specific torque	[Nm/bar]	7,8	7	6,3	5,5	4,7
Continuous speed	[rpm]	500	550	600	630	630
Peak speed	[rpm]	600	650	680	700	700
Minimum speed	[rpm]	2	2	2	2	2
Mechanical efficiency	[%]	87,5	86	85	83,6	82,4
Starting efficiency	[%]	82,5	81	80	77,2	74,3
Continuous power (**)	[kW]	65	65	65	60	50
Cont. power with flushing	[kW]	78	78	78	70	60
Continuous pressure	[bar]	270	270	270	270	270
Intermittent pressure	[bar]	310	310	310	310	310
Peak pressure	[bar]	350	350	350	350	350
Flushing flow	[l/min]	8	8	8	8	8
Dry weight	[kg]	68	68	68	68	68

Displacement (*)	[cc]	255	197	147	98
Th. specific torque	[Nm/bar]	4,1	3,1	2,3	1,6
Continuous speed	[rpm]	650	700	700	700
Peak speed	[rpm]	750	800	900	1000
Minimum speed	[rpm]	3	3	3	4
Mechanical efficiency	[%]	82	80	78	73,4
Starting efficiency	[%]	69,6	62,1	52	30
Continuous power (**)	[kW]	48	38	24	15
Cont. power with flushing	[kW]	55	41	28	18
Continuous pressure	[bar]	270	250	250	250
Intermittent pressure	[bar]	310	310	310	310
Peak pressure	[bar]	350	350	350	350
Flushing flow	[l/min]	8	8	8	8
Dry weight	[kg]	68	68	68	68

(*) Different displacements can be available on request. Please contact ItalgrouP S.r.l. for more information.

(**) The continuous power and the continuous power with flushing are the output maximum power. To estimate the input power divide the output power by the mechanical efficiency. For example: if required output power is 60 kW and starting efficiency is 82,5%, estimated required power is $60/0.825 = 72,7$ kW.

Hydrostatic pressure test: 420 bar.

Temperature range: -30 / 70 °C.

IAC 500 H3 - INSTALLATION DRAWING

XY DISPLACEMENT CHANGE CONFIGURATION

VIEW FROM Z

X - minimum displacement
Y - maximum displacement

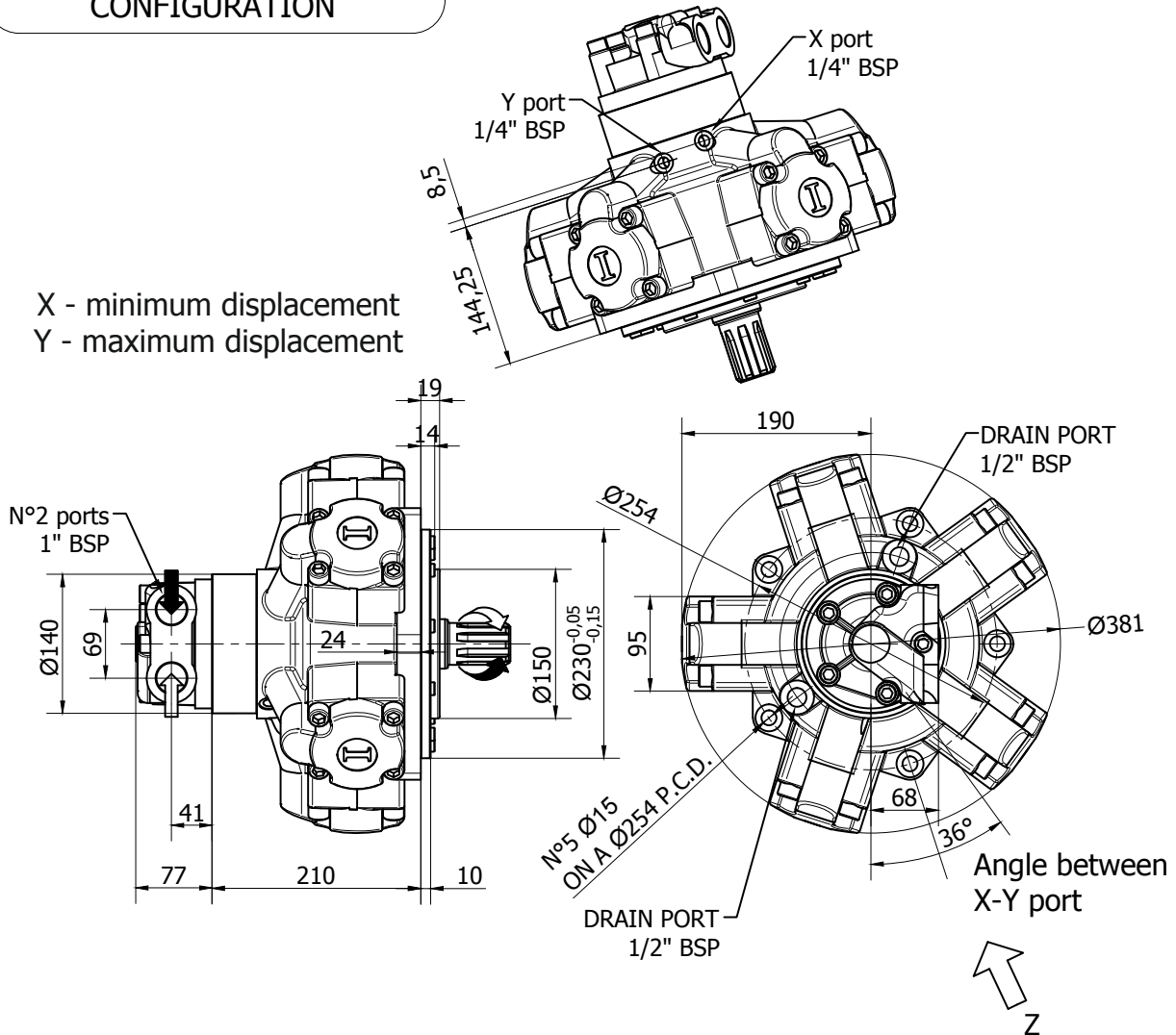

SHAFT TYPE: A0

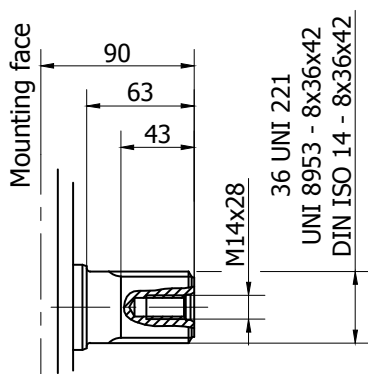

SHAFT TYPE: A3

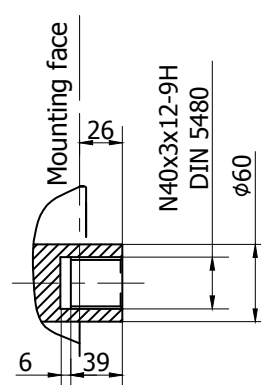

The data specified into the catalogue are for product description purpose only and must not be interpreted as warranted characteristics in legal sense. Italgrou S.r.l. reserves the right to implement modifications without notice. All partial or total reproduction and copy without written authorization of Italgrou S.r.l. is strictly forbidden.

XY DISPLACEMENT CHANGE CONFIGURATION

X - minimum displacement
Y - maximum displacement

VIEW FROM Z

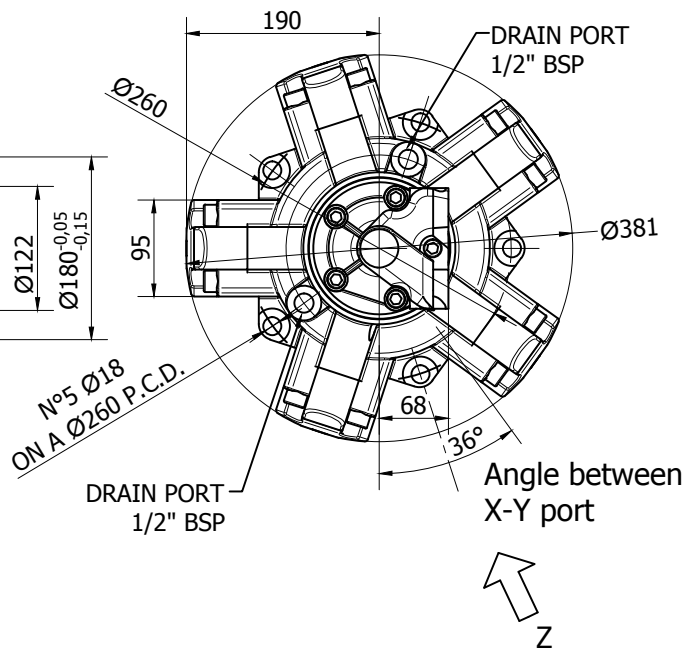
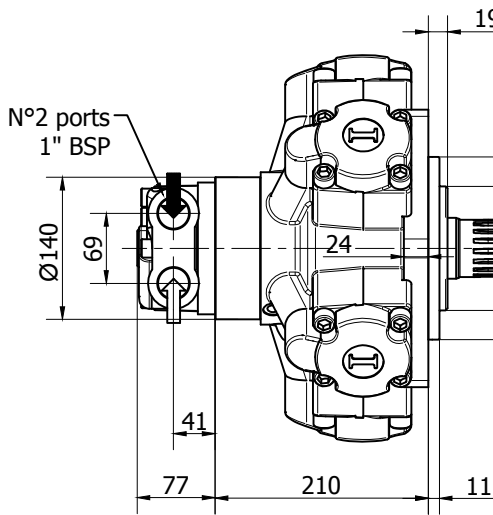
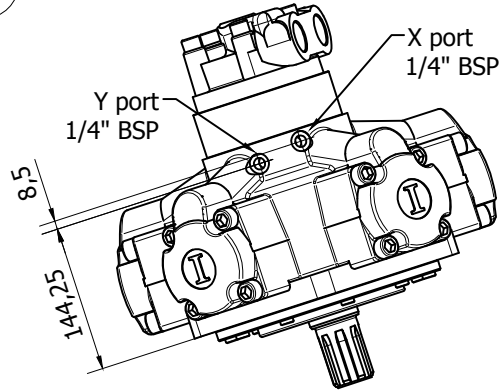

SHAFT TYPE: A1

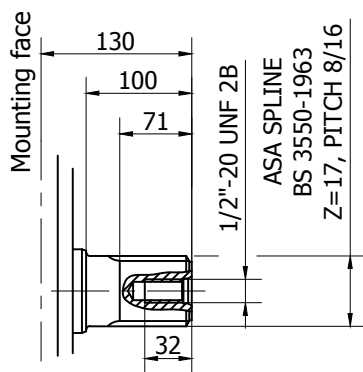

SHAFT TYPE: A2

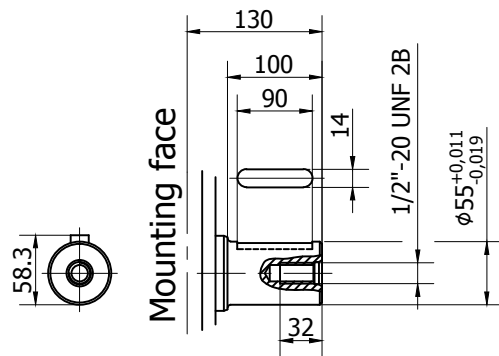

The data specified into the catalogue are for product description purpose only and must not be interpreted as warranted characteristics in legal sense. Italgrou S.r.l. reserves the right to implement modifications without notice. All partial or total reproduction and copy without written authorization of Italgrou S.r.l. is strictly forbidden.

IAC 500/C H3 - INSTALLATION DRAWING

XY DISPLACEMENT CHANGE CONFIGURATION

VIEW FROM Z

X - minimum displacement
Y - maximum displacement

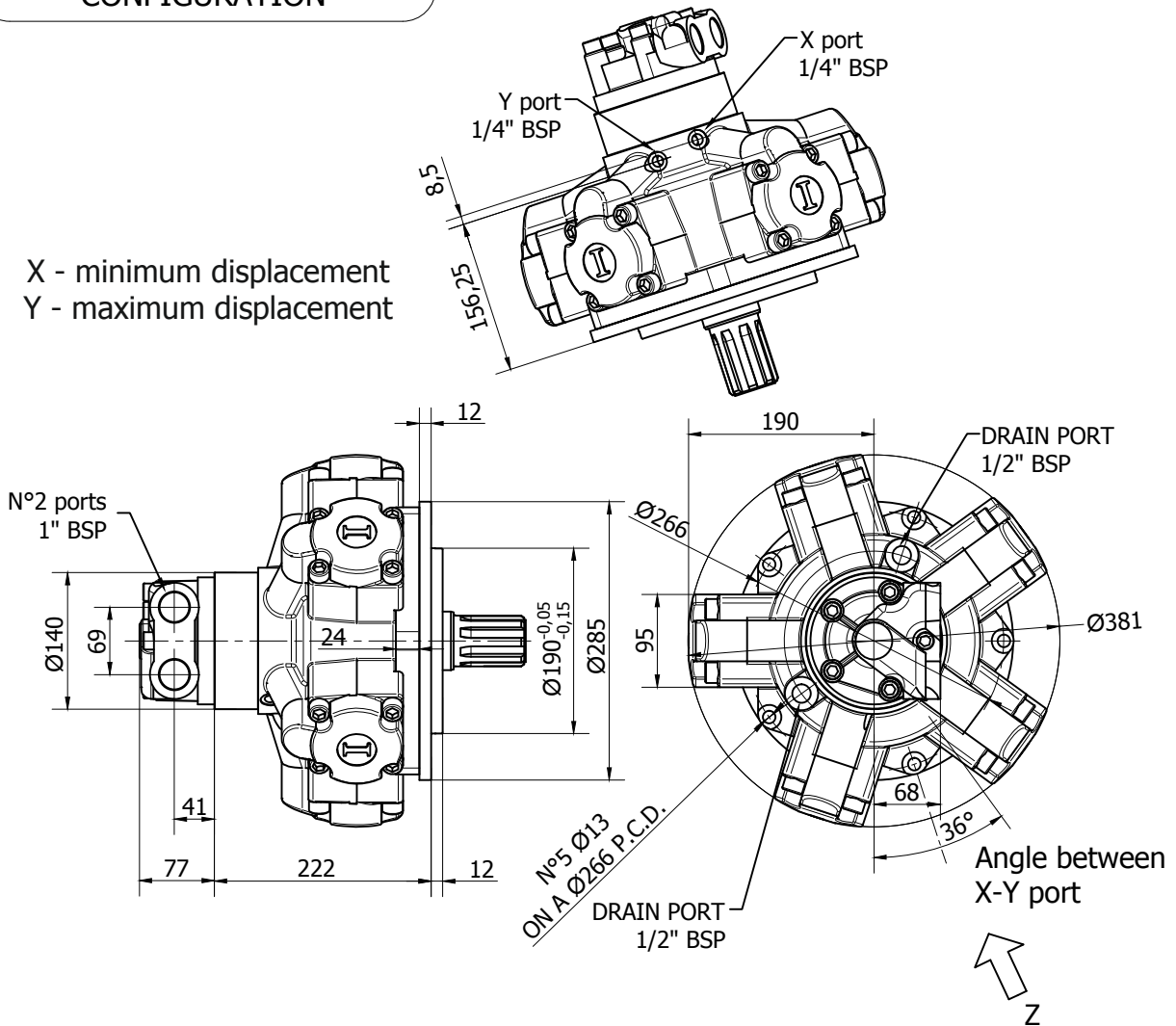

SHAFT TYPE: A0

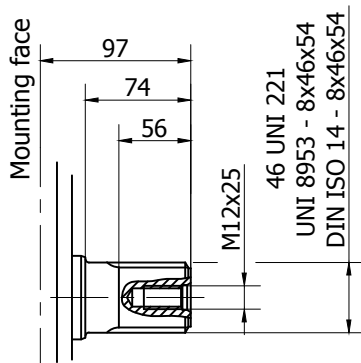

SHAFT TYPE: A11

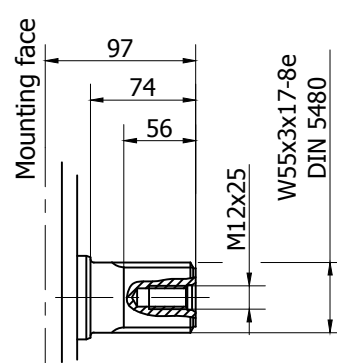

The data specified into the catalogue are for product description purpose only and must not be interpreted as warranted characteristics in legal sense. Italgrou S.r.l. reserves the right to implement modifications without notice. All partial or total reproduction and copy without written authorization of Italgrou S.r.l. is strictly forbidden.

XY DISPLACEMENT CHANGE CONFIGURATION

X - minimum displacement
Y - maximum displacement

VIEW FROM Z

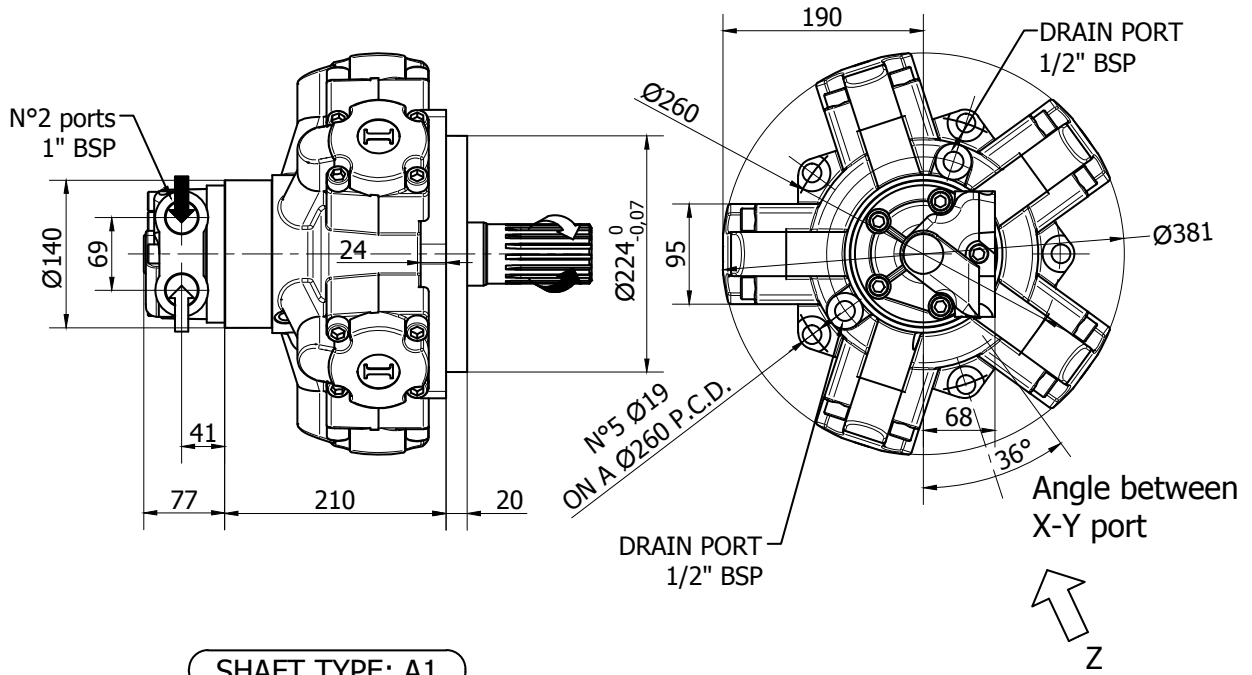
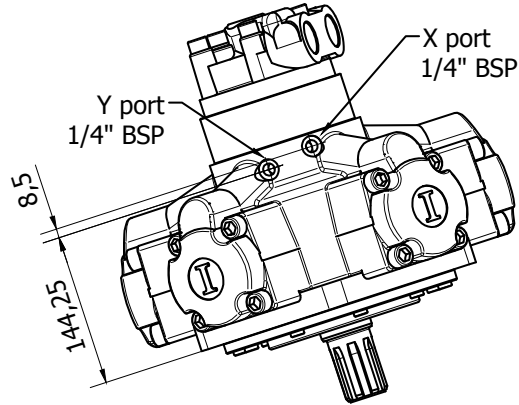

SHAFT TYPE: A1

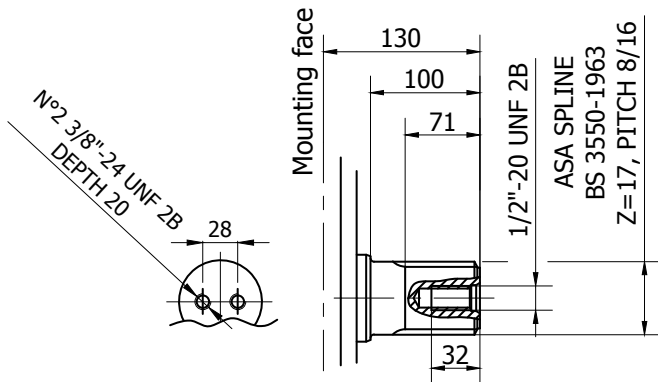

The data specified into the catalogue are for product description purpose only and must not be interpreted as warranted characteristics in legal sense. Italgrou S.r.l. reserves the right to implement modifications without notice. All partial or total reproduction and copy without written authorization of Italgrou S.r.l. is strictly forbidden.

XY DISPLACEMENT CHANGE
CONFIGURATION

X - minimum displacement
Y - maximum displacement

VIEW FROM Z

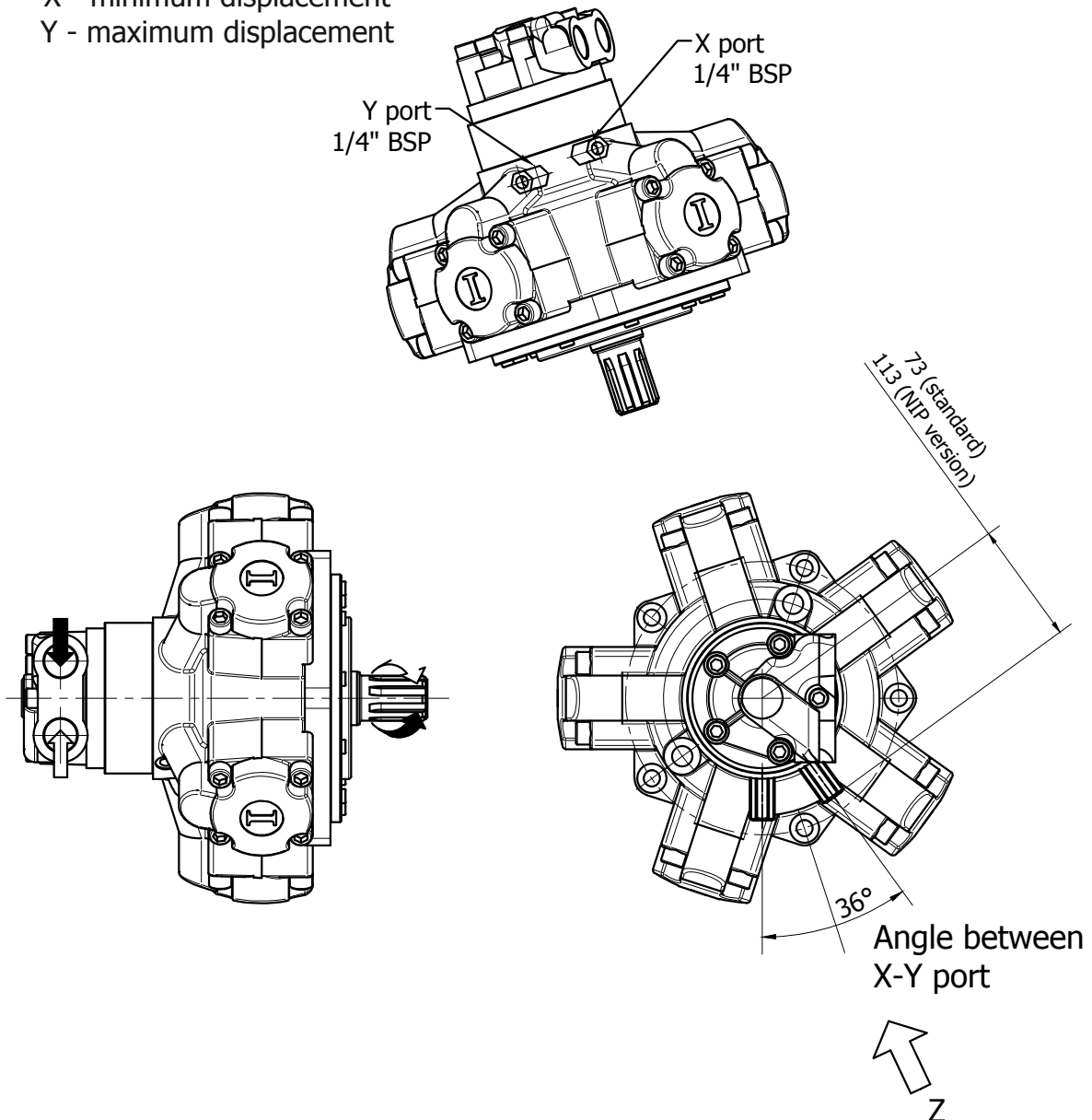

The data specified into the catalogue are for product description purpose only and must not be interpreted as warranted characteristics in legal sense. Italgroup S.r.l. reserves the right to implement modifications without notice. All partial or total reproduction and copy without written authorization of Italgroup S.r.l. is strictly forbidden.

**CETOP 3 DISPLACEMENT
 CHANGE CONFIGURATION**

CETOP 3
 FITTING

VIEW FROM Z

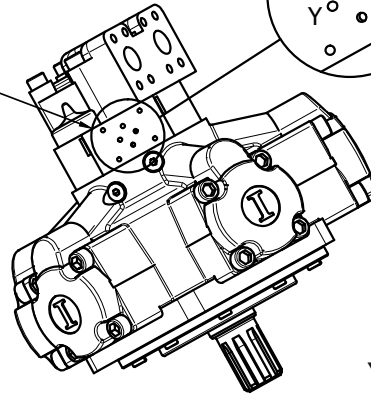
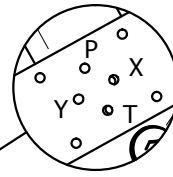

X - minimum displacement
 Y - maximum displacement

N°2 ports
 1" SAE 3000

Ø140
 69

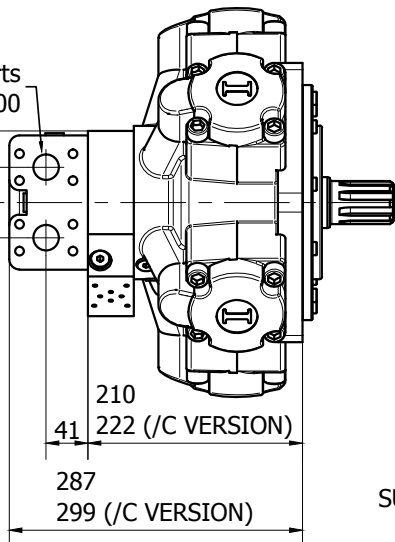

210
 222 (/C VERSION)

41
 287
 299 (/C VERSION)

CETOP 3
 SUPPLY PORT
 1/4" BSP

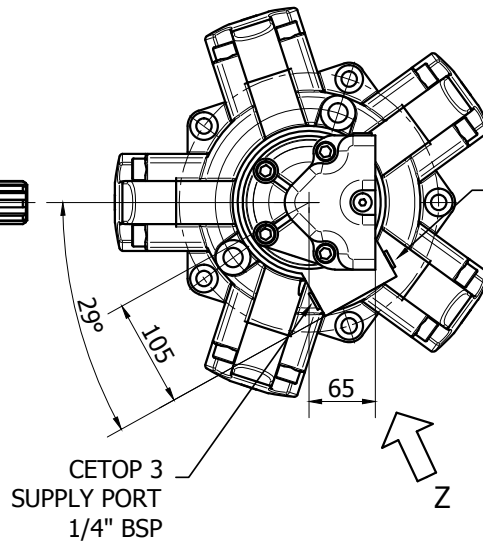

CETOP 3
 SUPPLY PORT
 1/4" BSP

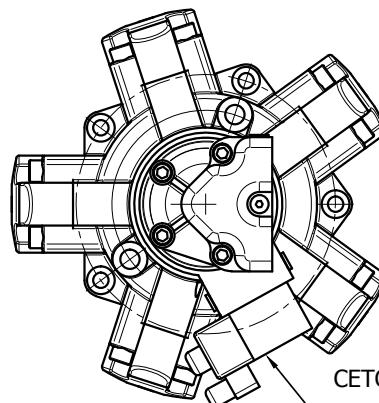
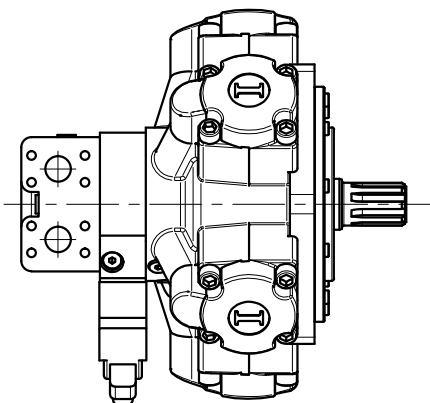

CETOP 3 DISPLACEMENT CHANGE
 VALVE

- C3 - 12 SV (12V DC)
- C3 - 24 SV (24V DC)
- C3 - HY SV (HYDRAULIC OPERATED)

The data specified into the catalogue are for product description purpose only and must not be interpreted as warranted characteristics in legal sense. Italgrou S.r.l. reserves the right to implement modifications without notice. All partial or total reproduction and copy without written authorization of Italgrou S.r.l. is strictly forbidden.

IAC 500 H3 - ORDERING CODE

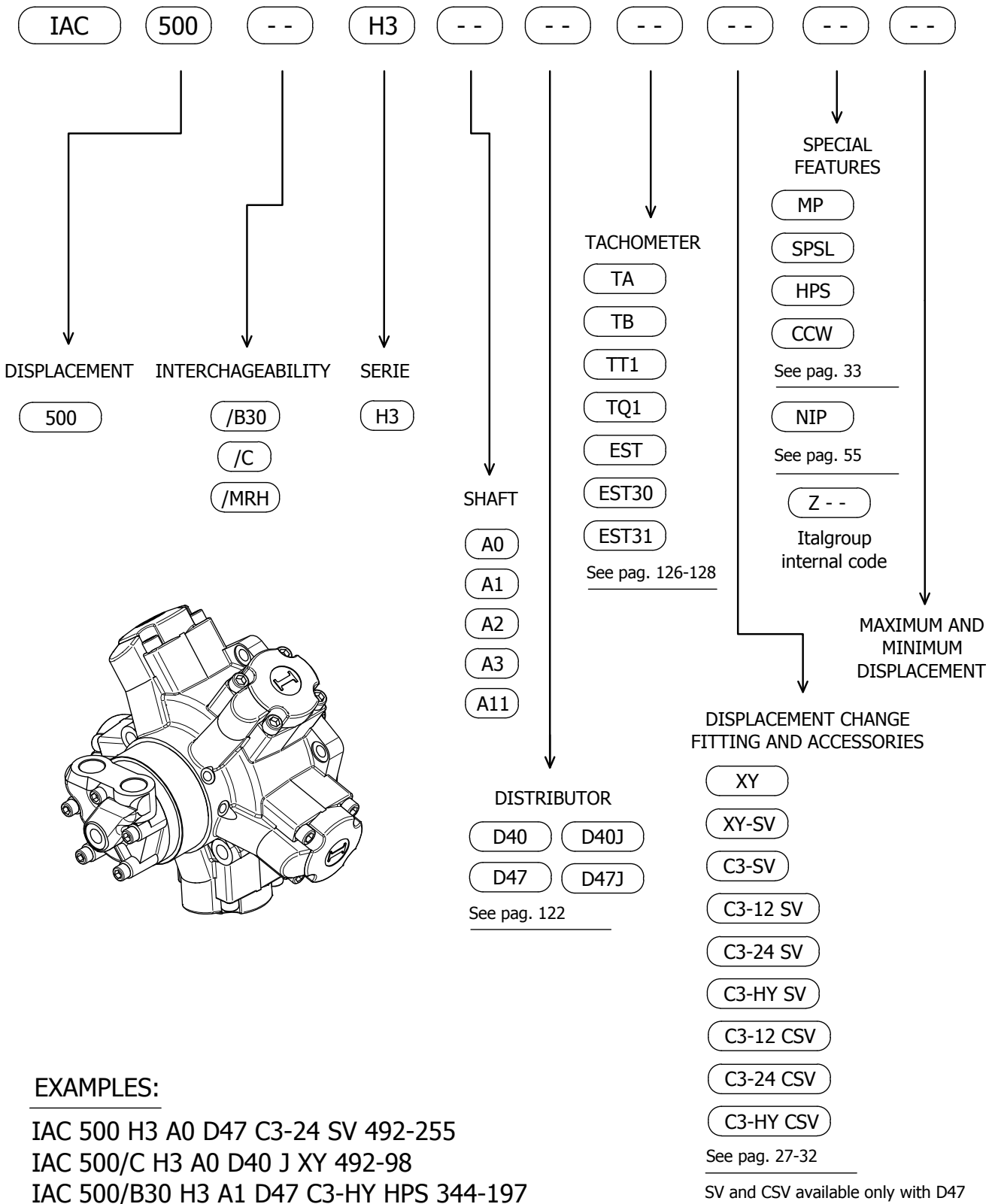

The data specified into the catalogue are for product description purpose only and must not be interpreted as warranted characteristics in legal sense. Italgroup S.r.l. reserves the right to implement modifications without notice. All partial or total reproduction and copy without written authorization of Italgroup S.r.l. is strictly forbidden.

492 cc - WITHOUT FLUSHING

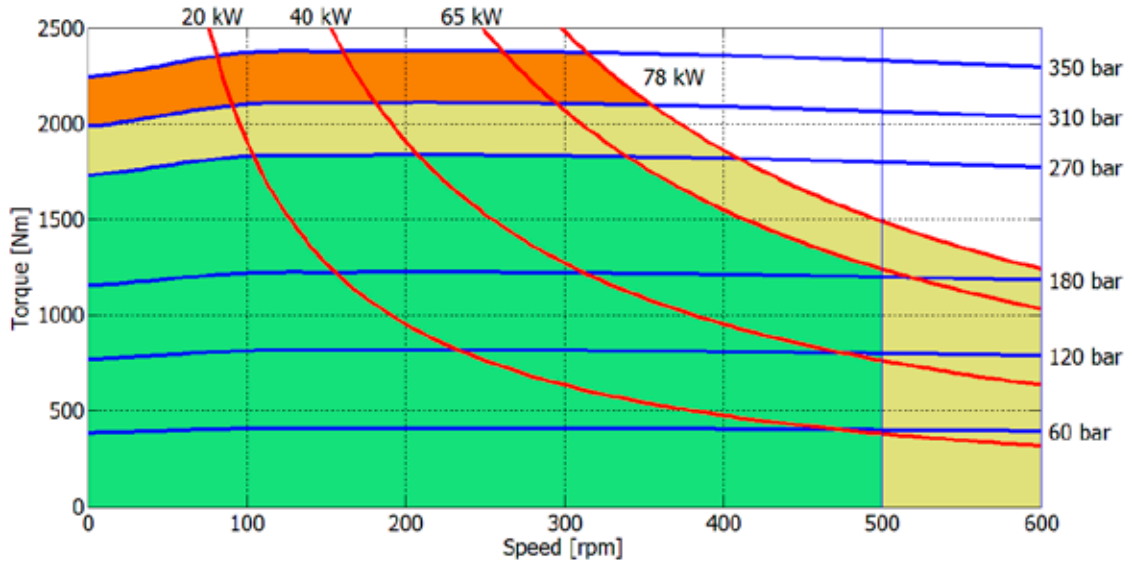

255 cc - WITHOUT FLUSHING

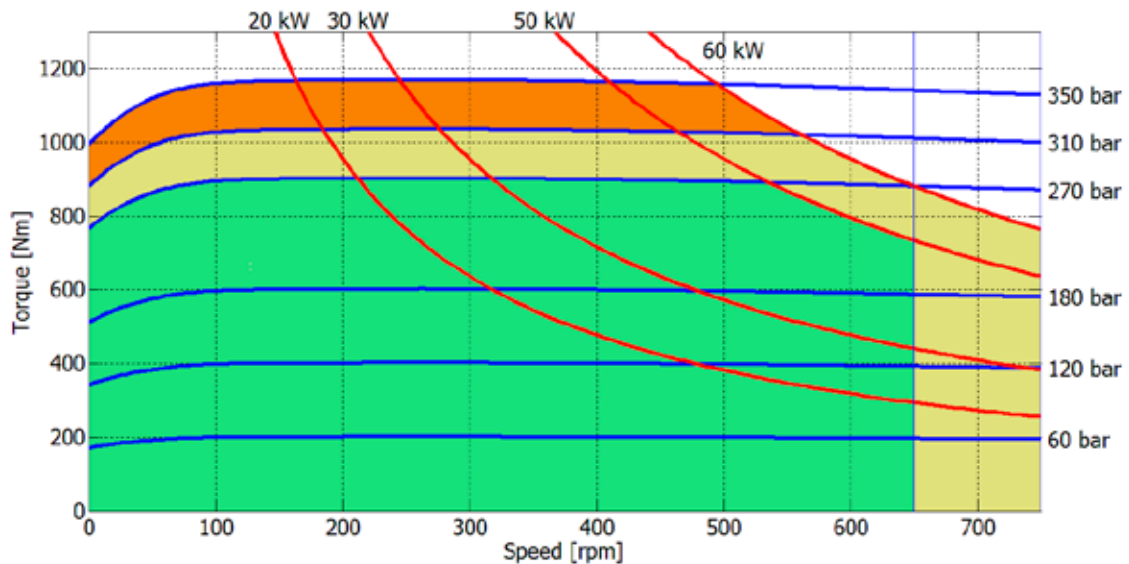

Continuous operation



Intermittent operation: permitted for a 15% of duty cycle, for 3 minutes maximum period.



Peak operation: permitted for very short periods (3-5 seconds every 10-15 minutes).

The above diagrams are referring to the hydraulic motor working with a fluid in ideal conditions (viscosity at 40 cSt). In case the working temperature increases and viscosity reach values under the recommended values (see hydraulic fluid recommendations) flushing must be performed or ISO oil grade must be changed. The working temperature must not overcome 70 °C.

492 cc - WITH FLUSHING

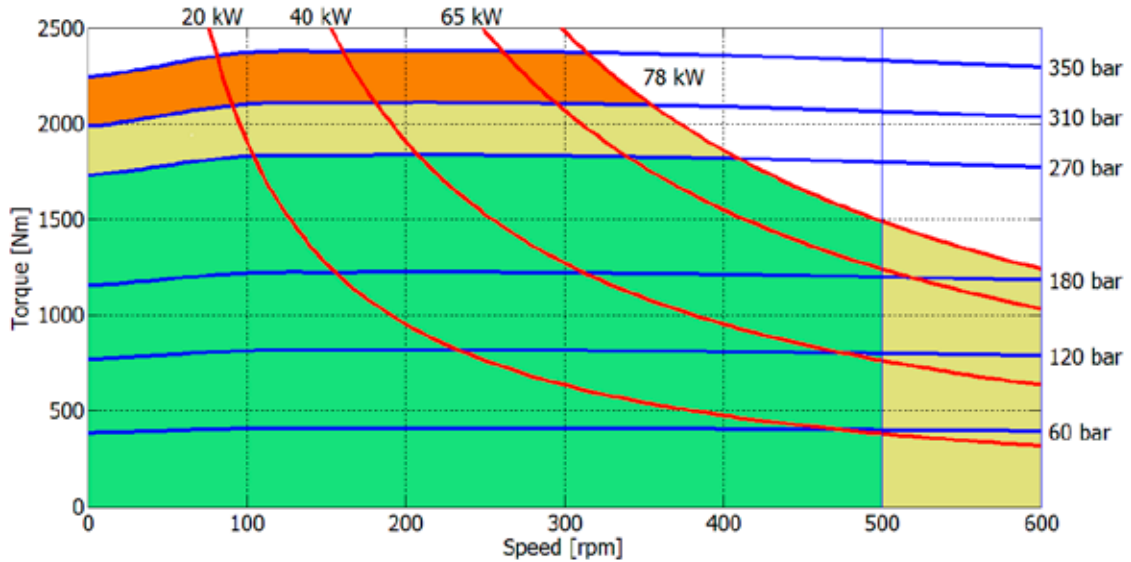

255 cc - WITH FLUSHING

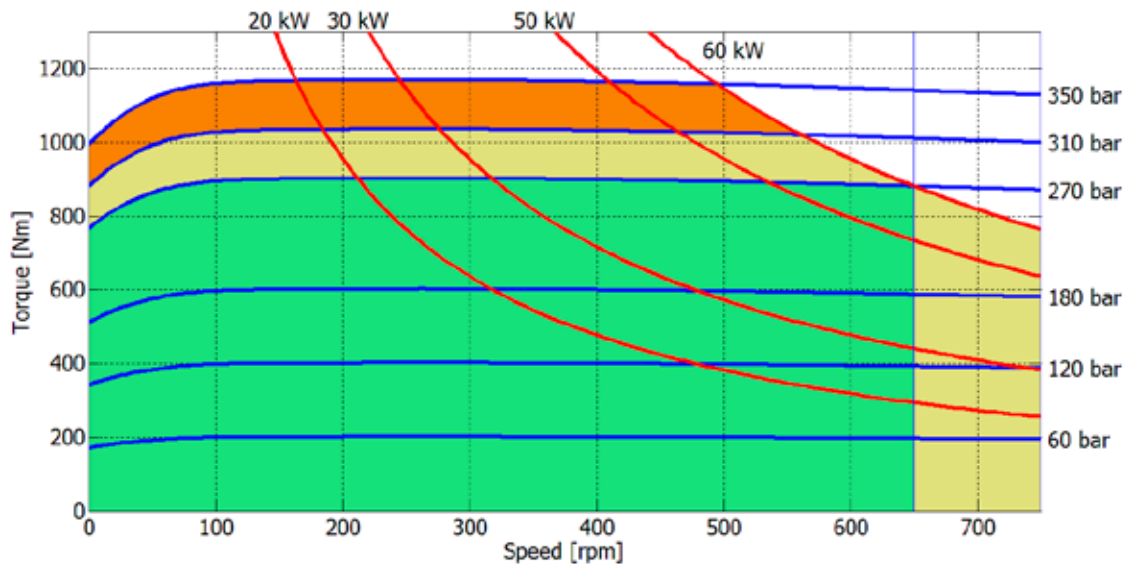

Continuous operation



Intermittent operation: permitted for a 15% of duty cycle, for 3 minutes maximum period.



Peak operation: permitted for very short periods (3-5 seconds every 10-15 minutes).

The above diagrams are referring to the hydraulic motor working with a fluid in ideal conditions (viscosity at 40 cSt). In case the working temperature increases and viscosity reach values under the recommended values (see hydraulic fluid recommendations) flushing must be optimized or ISO oil grade must be changed. The working temperature must not overcome 70 °C.

CREEP SPEED - VOLUMETRIC EFFICIENCY

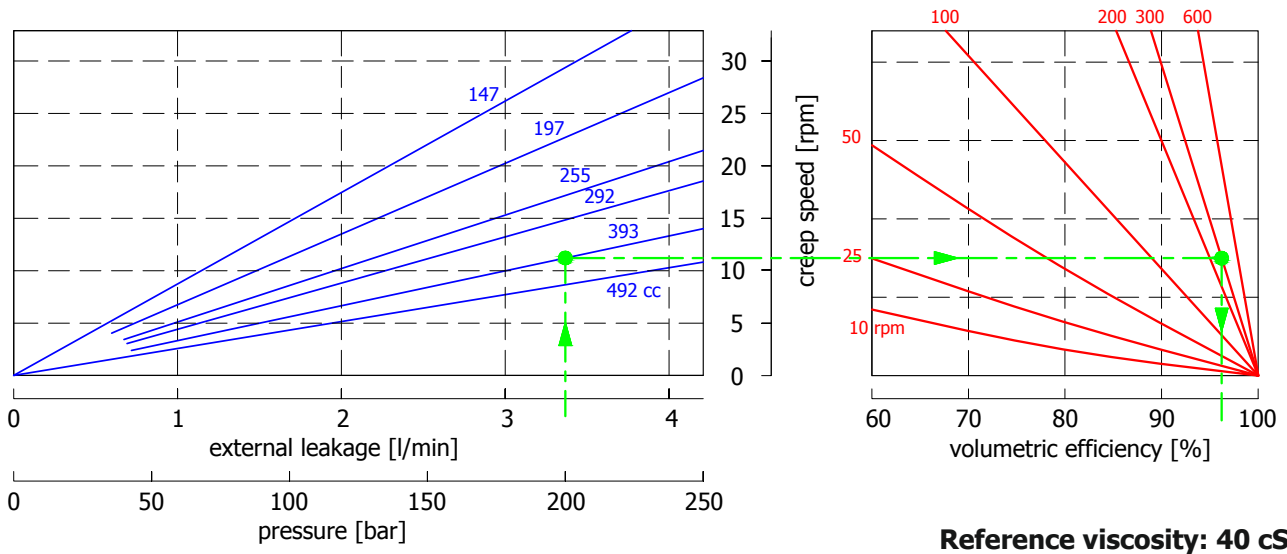

Example:

We suppose (393 cc): $p=200$ [bar], we obtain: external leakage 3,3 [l/min], shaft creep speed 11.5 [rpm].

If we suppose (393 cc): $p=200$ [bar] and $n=300$ [rpm] we obtain a volumetric efficiency of 97%;

BEARING LIFE

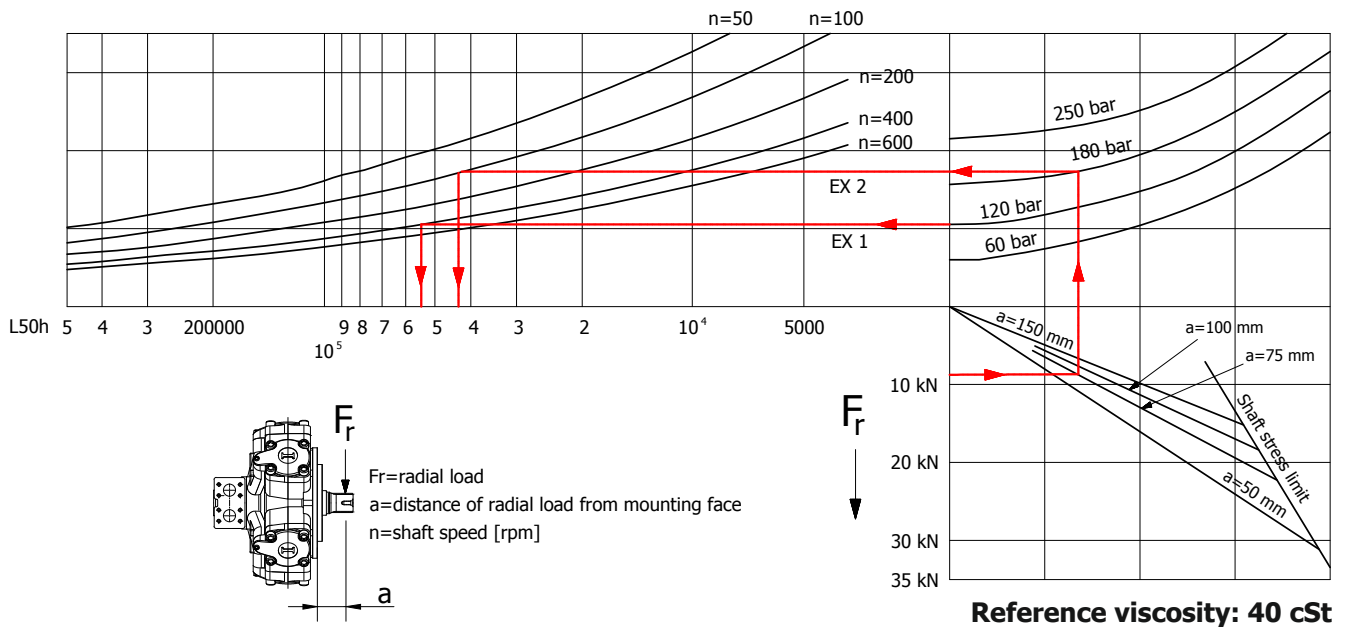

Example:

We suppose (EX1): $p=120$ [bar], $n=400$ [rpm]; we obtain an average lifetime of 53000 [h].

If we suppose (EX2): $F_r=9$ [kN], $a=75$ [mm], $p=180$ [bar] and $n=100$ [rpm], we obtain an average lifetime of 42000 [h].

The data specified into the catalogue are for product description purpose only and must not be interpreted as warranted characteristics in legal sense. Italgrou S.r.l. reserves the right to implement modifications without notice. All partial or total reproduction and copy without written authorization of Italgrou S.r.l. is strictly forbidden.

ITALGROUP SRL
IAC SERIES - IAC H4
GENERAL CATALOGUE

INDEX - IAC H4

TECHNICAL DATA	Pag	62
IAC 800 H4 - INSTALLATION DRAWING	“	63
IAC 800/B45 H4 - INSTALLATION DRAWING	“	64
IAC 800/C H4 - INSTALLATION DRAWING	“	65
IAC 800/MRH H4 - INSTALLATION DRAWING	“	66
IAC H4 - NIP OPTION	“	67
IAC H4 - CETOP 3 FITTING	“	68
IAC H4 - ORDERING CODE	“	69
IAC 800 H4 - PERFORMANCE DIAGRAMS	“	70 - 71

IAC 800 H4

Displacement (*)	[cc]	792	660	575	493	410
Th. specific torque	[Nm/bar]	12,6	10,5	9,2	7,8	6,5
Continuous speed	[rpm]	450	550	620	650	650
Peak speed	[rpm]	550	700	720	750	800
Minimum speed	[rpm]	2	2	2	2	2
Mechanical efficiency	[%]	90,8	90,4	88,5	88	87,4
Starting efficiency	[%]	84,8	84,4	82,6	79	75
Continuous power (**)	[kW]	105	92	82	70	54
Cont. power with flushing	[kW]	125	110	98	84	65
Continuous pressure	[bar]	270	270	270	270	270
Intermittent pressure	[bar]	310	310	310	310	310
Peak pressure	[bar]	350	350	350	350	350
Flushing flow	[l/min]	10	10	10	10	10
Dry weight	[kg]	92	92	92	92	92

Displacement (*)	[cc]	328	273	245	165
Th. specific torque	[Nm/bar]	5,2	4,3	3,9	2,6
Continuous speed	[rpm]	700	700	700	700
Peak speed	[rpm]	800	850	850	900
Minimum speed	[rpm]	2	2	3	3
Mechanical efficiency	[%]	84,5	82,4	82	60,2
Starting efficiency	[%]	70,2	68,3	60,8	43,3
Continuous power (**)	[kW]	54	42	40	18
Cont. power with flushing	[kW]	65	50	48	24
Continuous pressure	[bar]	250	250	250	250
Intermittent pressure	[bar]	310	310	310	310
Peak pressure	[bar]	350	350	350	350
Flushing flow	[l/min]	10	10	10	10
Dry weight	[kg]	92	92	92	92

(*) Different displacements can be available on request. Please contact Italgroupp S.r.l. for more information.

(**) The continuous power and the continuous power with flushing are the output maximum power. To estimate the input power divide the output power by the mechanical efficiency. For example: if required output power is 100 kW and starting efficiency is 90.8%, estimated required power is $100/0.908 = 110,1$ kW.

Hydrostatic pressure test: 420 bar.

Temperature range: -30 / 70 °C.

IAC 800 H4 - INSTALLATION DRAWING

XY DISPLACEMENT CHANGE CONFIGURATION

X - minimum displacement
Y - maximum displacement

VIEW FROM Z

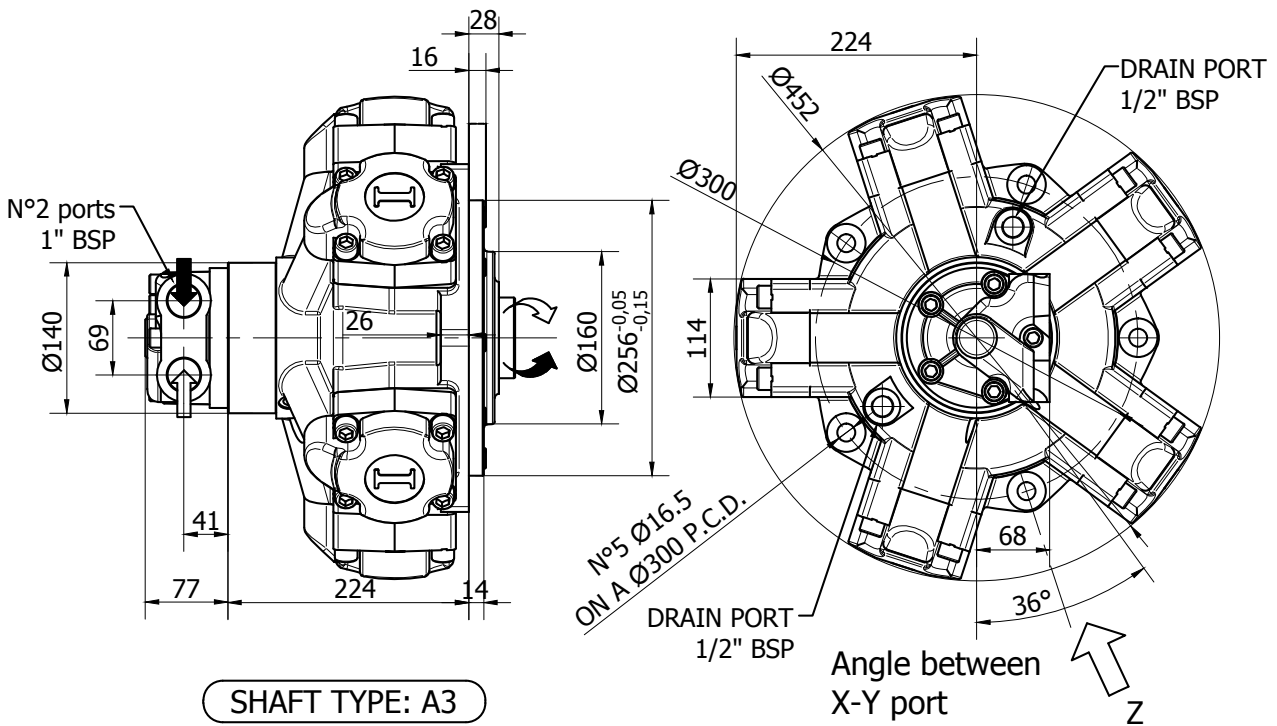
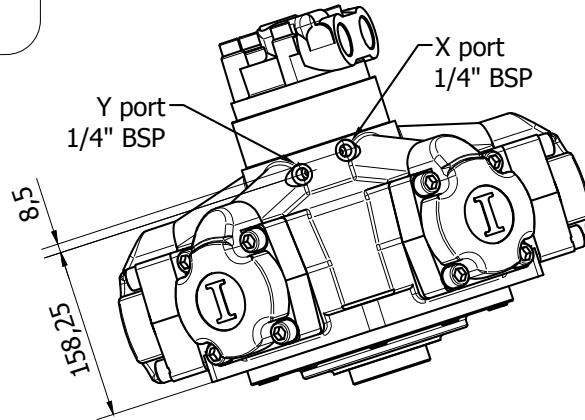

SHAFT TYPE: A3

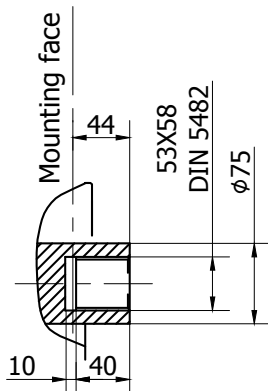

The data specified into the catalogue are for product description purpose only and must not be interpreted as warranted characteristics in legal sense. Italgrou S.r.l. reserves the right to implement modifications without notice. All partial or total reproduction and copy without written authorization of Italgrou S.r.l. is strictly forbidden.

XY DISPLACEMENT CHANGE CONFIGURATION

X - minimum displacement
Y - maximum displacement

VIEW FROM Z

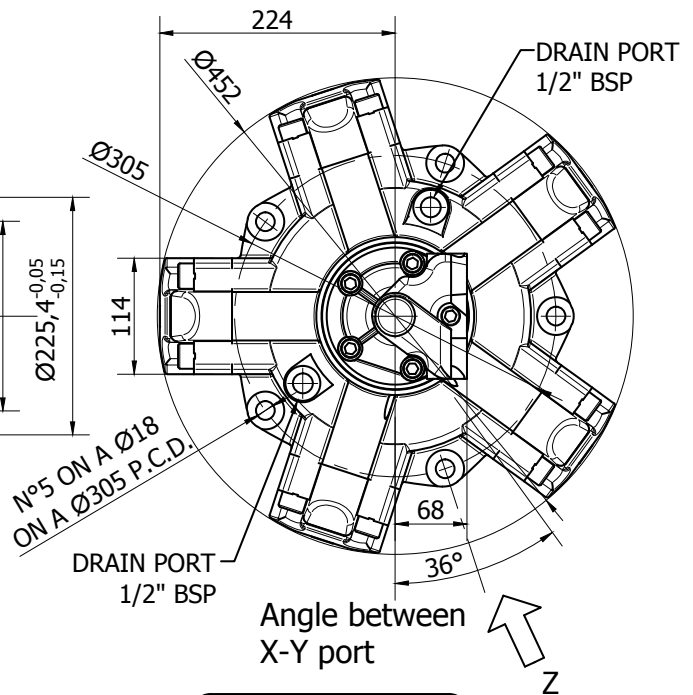
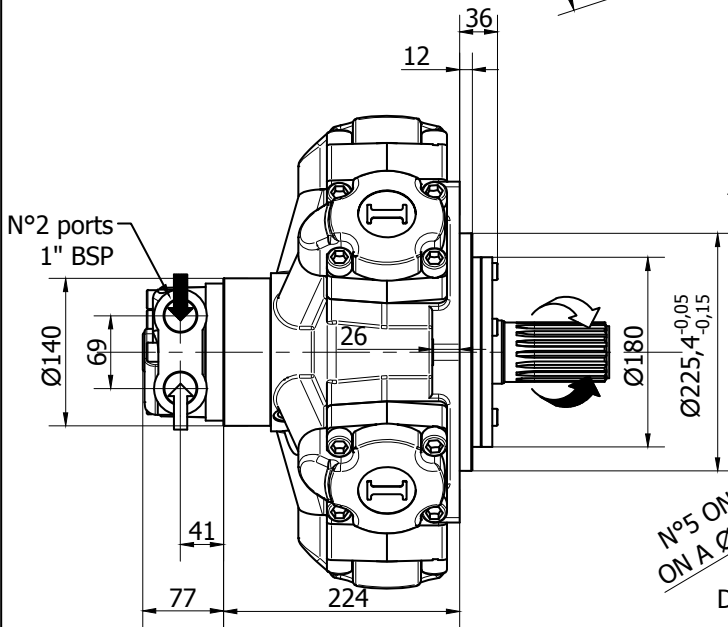
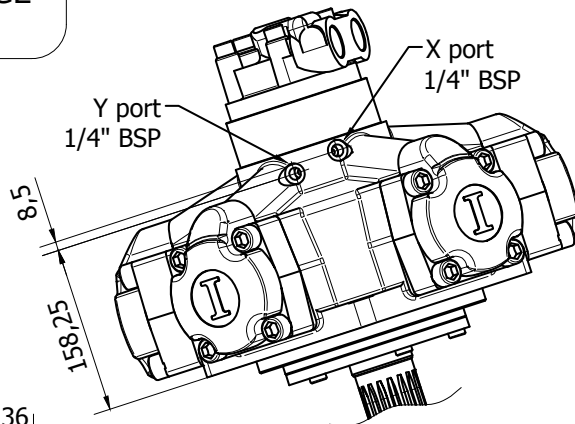

SHAFT TYPE: A1

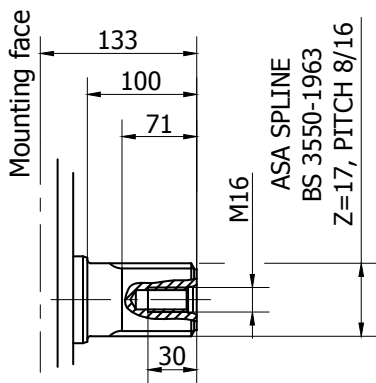

SHAFT TYPE: A2

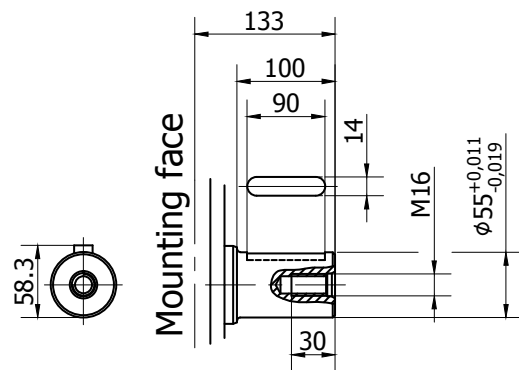

The data specified into the catalogue are for product description purpose only and must not be interpreted as warranted characteristics in legal sense. Italgrou S.r.l. reserves the right to implement modifications without notice. All partial or total reproduction and copy without written authorization of Italgrou S.r.l. is strictly forbidden.

IAC 800/C H4 - INSTALLATION DRAWING

XY DISPLACEMENT CHANGE CONFIGURATION

X - minimum displacement
Y - maximum displacement

VIEW FROM Z

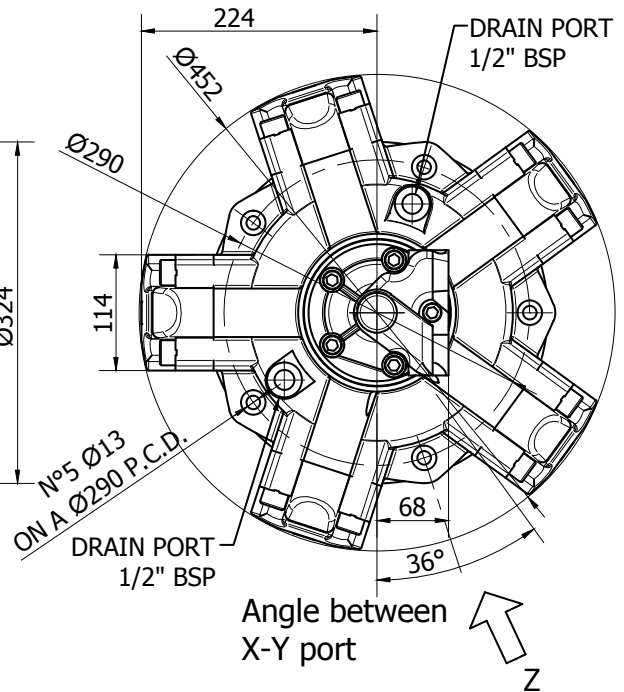
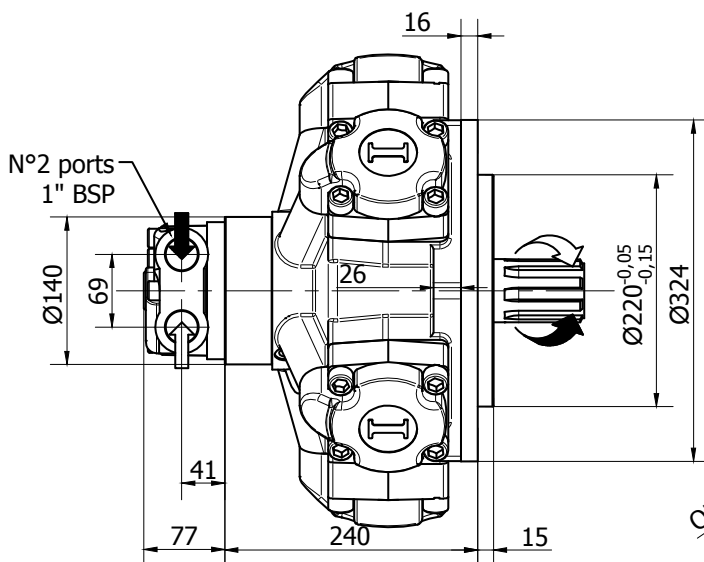
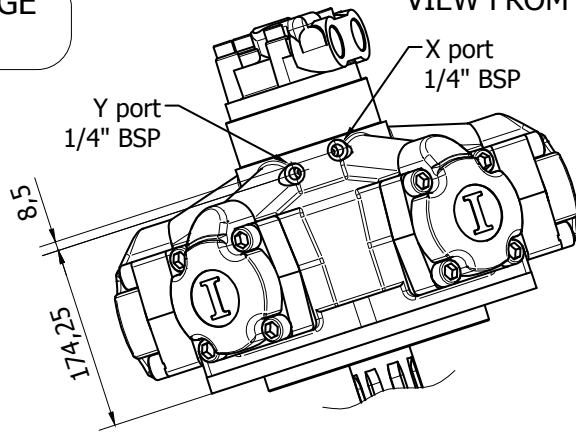

SHAFT TYPE: A0

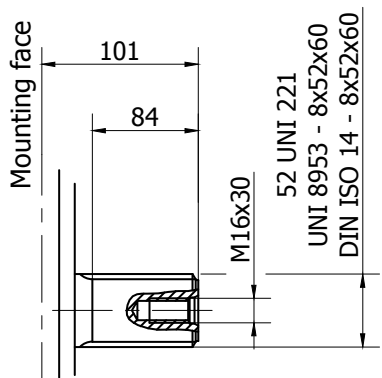

SHAFT TYPE: A3

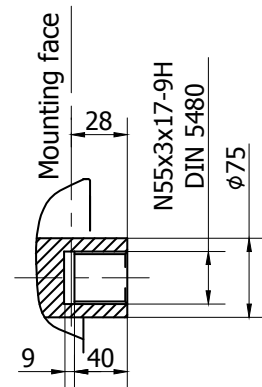

The data specified into the catalogue are for product description purpose only and must not be interpreted as warranted characteristics in legal sense. Italgrou S.r.l. reserves the right to implement modifications without notice. All partial or total reproduction and copy without written authorization of Italgrou S.r.l. is strictly forbidden.

XY DISPLACEMENT CHANGE CONFIGURATION

X - minimum displacement
Y - maximum displacement

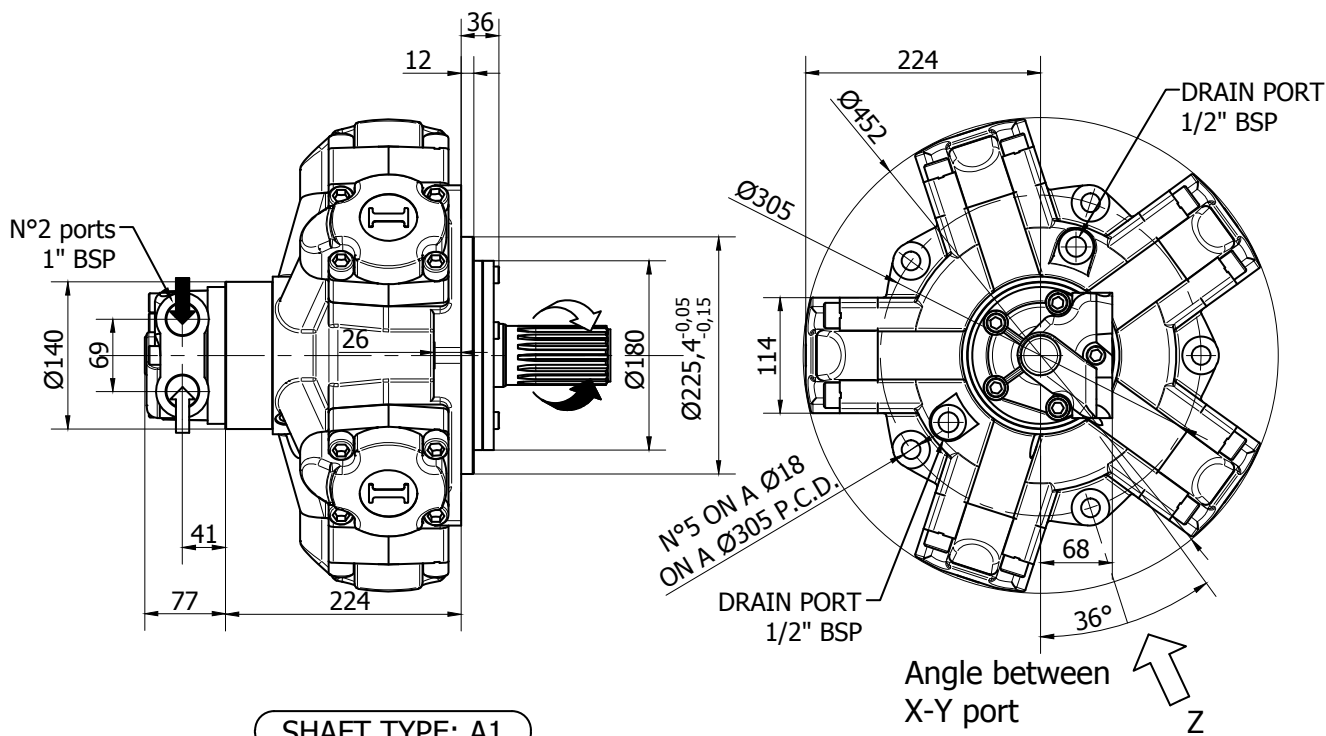
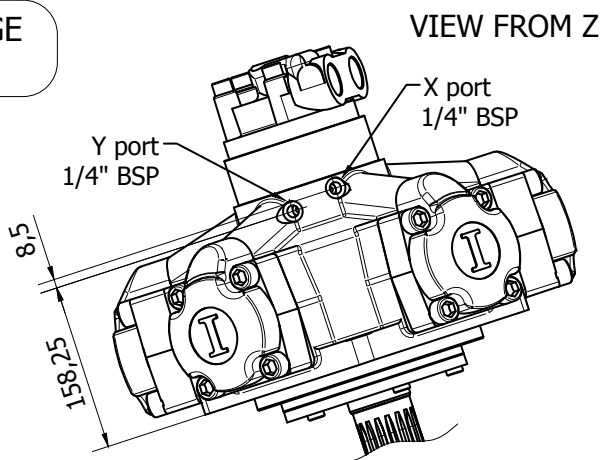

SHAFT TYPE: A1

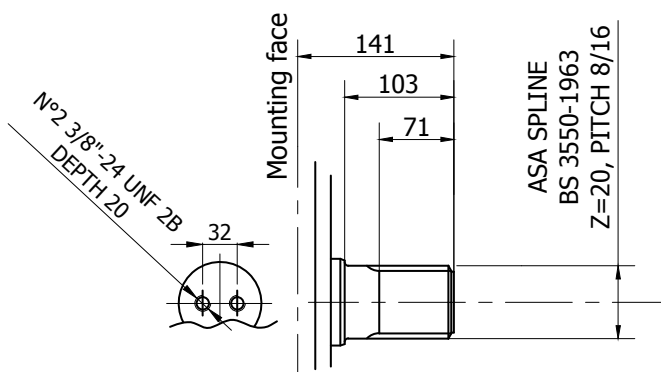

The data specified into the catalogue are for product description purpose only and must not be interpreted as warranted characteristics in legal sense. Italgrou S.r.l. reserves the right to implement modifications without notice. All partial or total reproduction and copy without written authorization of Italgrou S.r.l. is strictly forbidden.

XY DISPLACEMENT CHANGE
CONFIGURATION

X - minimum displacement
Y - maximum displacement

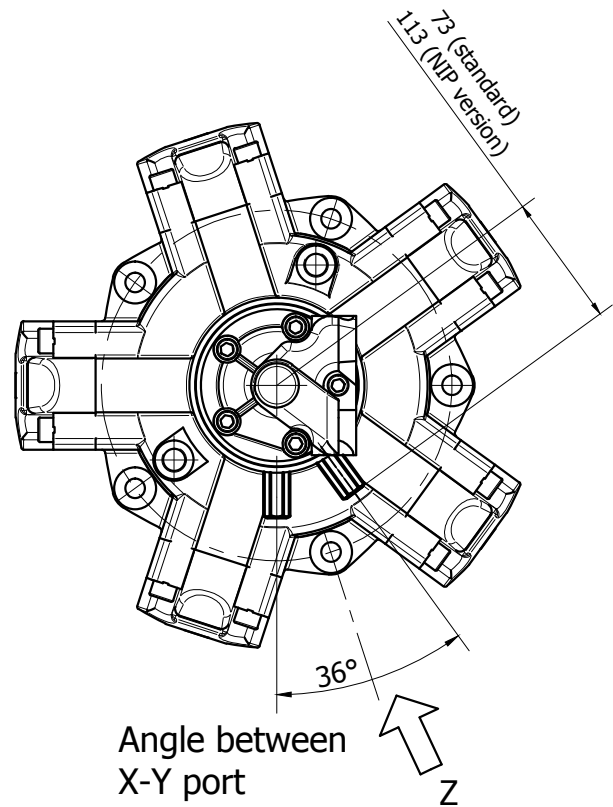
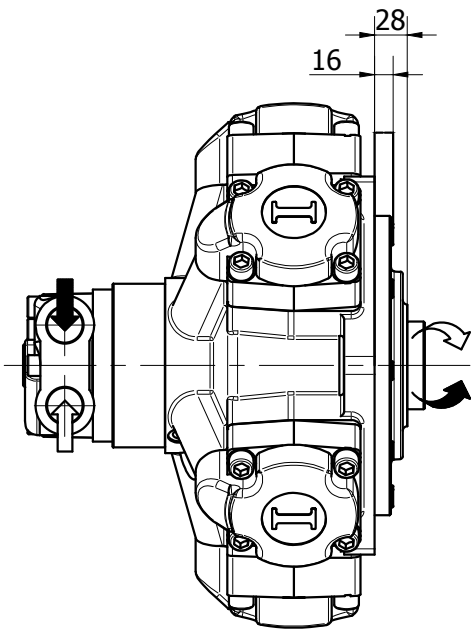
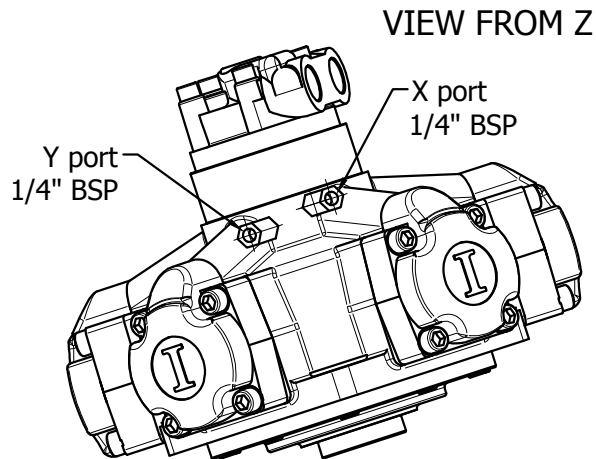

**CETOP 3 DISPLACEMENT
 CHANGE CONFIGURATION**

VIEW FROM Z

CETOP 3
 FITTING

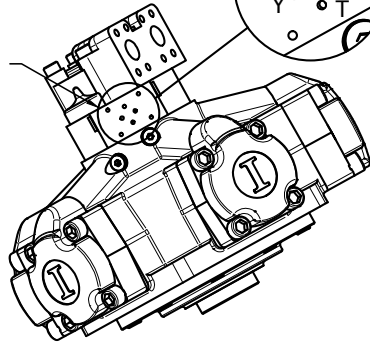
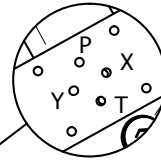

X - minimum displacement
 Y - maximum displacement

N°2 ports
 1" SAE 3000

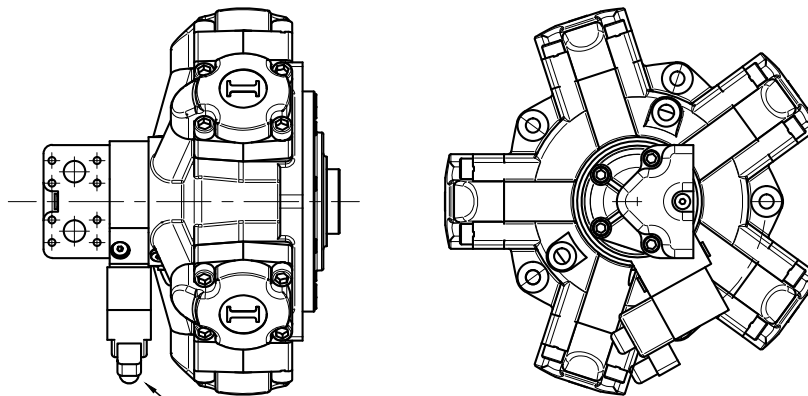
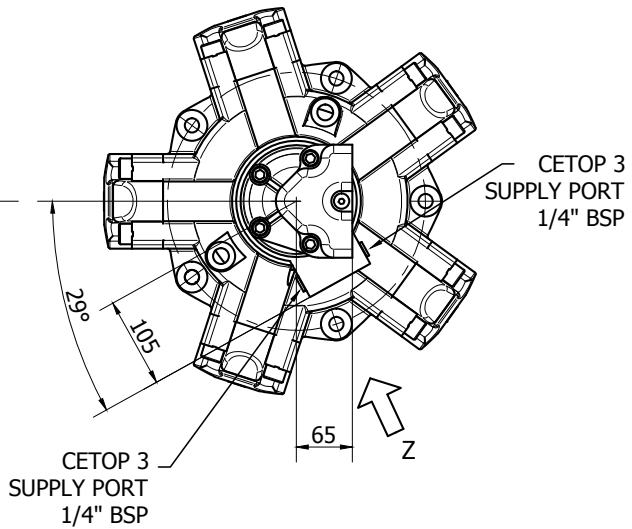
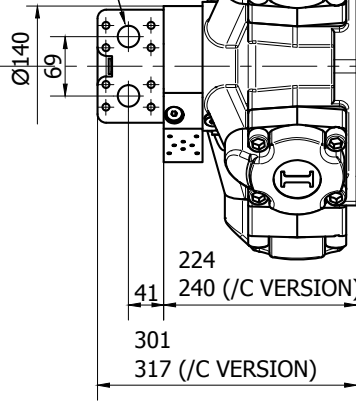

CETOP 3 DISPLACEMENT CHANGE
 VALVE
 C3 - 12 SV (12V DC)
 C3 - 24 SV (24V DC)
 C3 - HY SV (HYDRAULIC
 OPERATED)

The data specified into the catalogue are for product description purpose only and must not be interpreted as warranted characteristics in legal sense. Italgrou S.r.l. reserves the right to implement modifications without notice. All partial or total reproduction and copy without written authorization of Italgrou S.r.l. is strictly forbidden.

IAC 800 H4 - ORDERING CODE

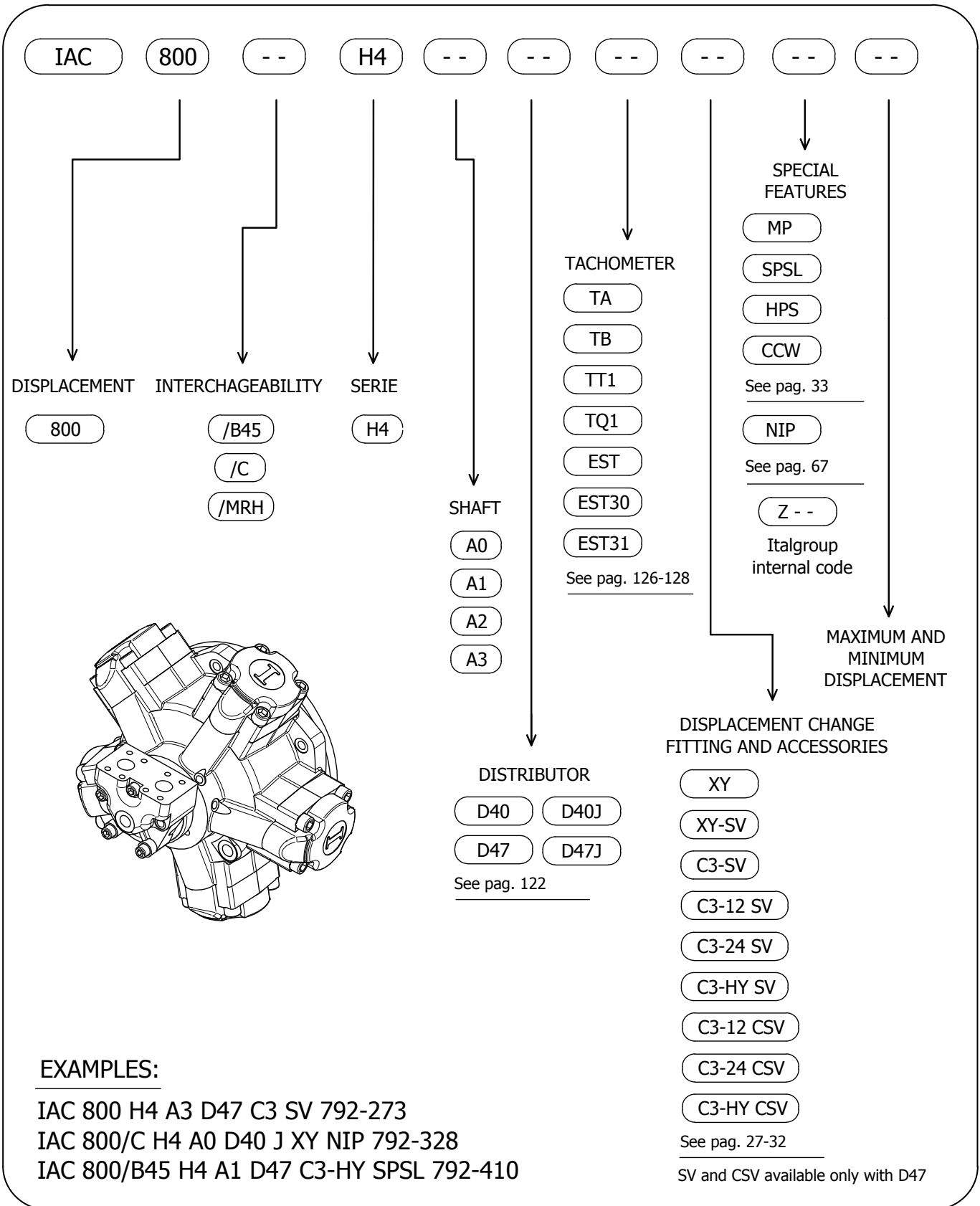

The data specified into the catalogue are for product description purpose only and must not be interpreted as warranted characteristics in legal sense. ItalgrouP S.r.l. reserves the right to implement modifications without notice. All partial or total reproduction and copy without written authorization of ItalgrouP S.r.l. is strictly forbidden.

792 cc - WITHOUT FLUSHING

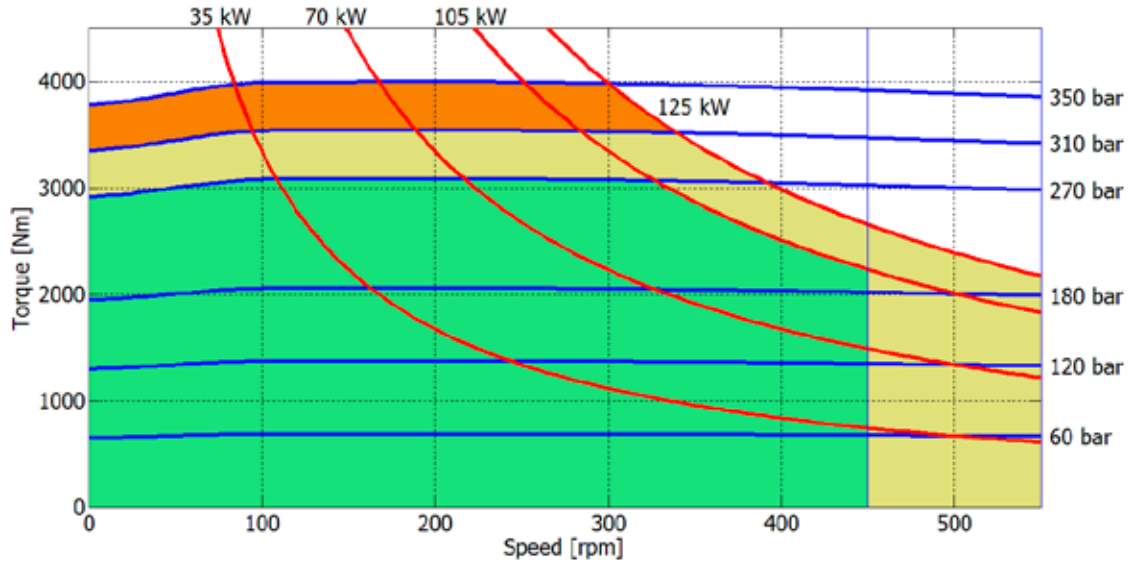

410 cc - WITHOUT FLUSHING

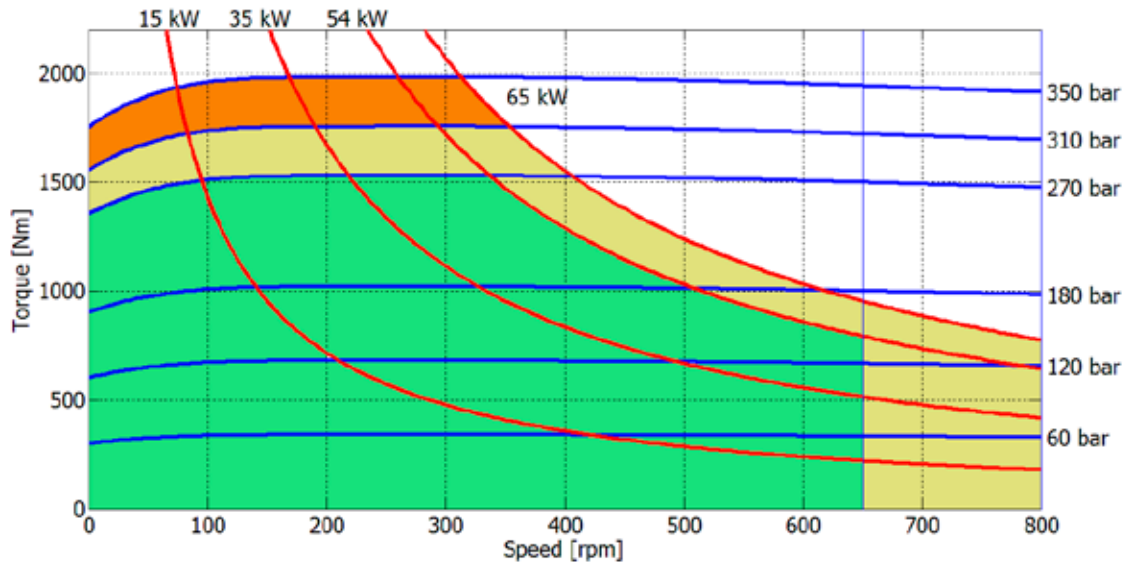

Continuous operation



Intermittent operation: permitted for a 15% of duty cycle, for 3 minutes maximum period.



Peak operation: permitted for very short periods (3-5 seconds every 10-15 minutes).

The above diagrams are referring to the hydraulic motor working with a fluid in ideal conditions (viscosity at 40 cSt). In case the working temperature increases and viscosity reach values under the recommended values (see hydraulic fluid recommendations) flushing must be performed or ISO oil grade must be changed. The working temperature must not overcome 70 °C.

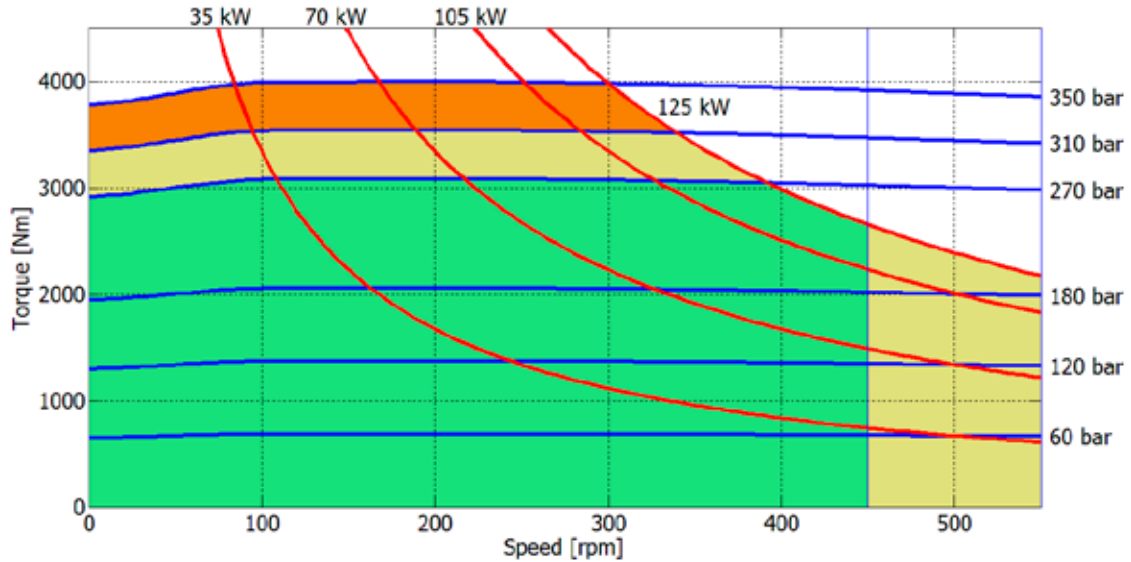

The data specified into the catalogue are for product description purpose only and must not be interpreted as warranted characteristics in legal sense. Italgroup S.r.l. reserves the right to implement modifications without notice. All partial or total reproduction and copy without written authorization of Italgroup S.r.l. is strictly forbidden.

792 cc - WITH FLUSHING

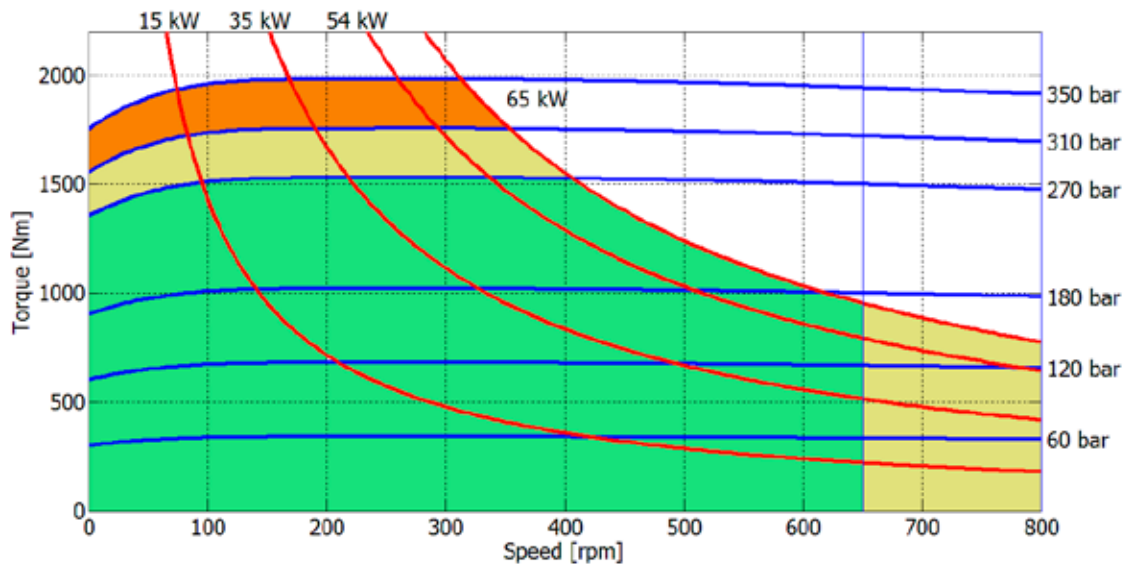

410 cc - WITH FLUSHING



-  Continuous operation
-  Intermittent operation: permitted for a 15% of duty cycle, for 3 minutes maximum period.
-  Peak operation: permitted for very short periods (3-5 seconds every 10-15 minutes).

The above diagrams are referring to the hydraulic motor working with a fluid in ideal conditions (viscosity at 40 cSt). In case the working temperature increases and viscosity reach values under the recommended values (see hydraulic fluid recommendations) flushing must be optimized or ISO oil grade must be changed. The working temperature must not overcome 70 °C.

The data specified into the catalogue are for product description purpose only and must not be interpreted as warranted characteristics in legal sense. ItalgrouP S.r.l. reserves the right to implement modifications without notice. All partial or total reproduction and copy without written authorization of ItalgrouP S.r.l. is strictly forbidden.

CREEP SPEED - VOLUMETRIC EFFICIENCY

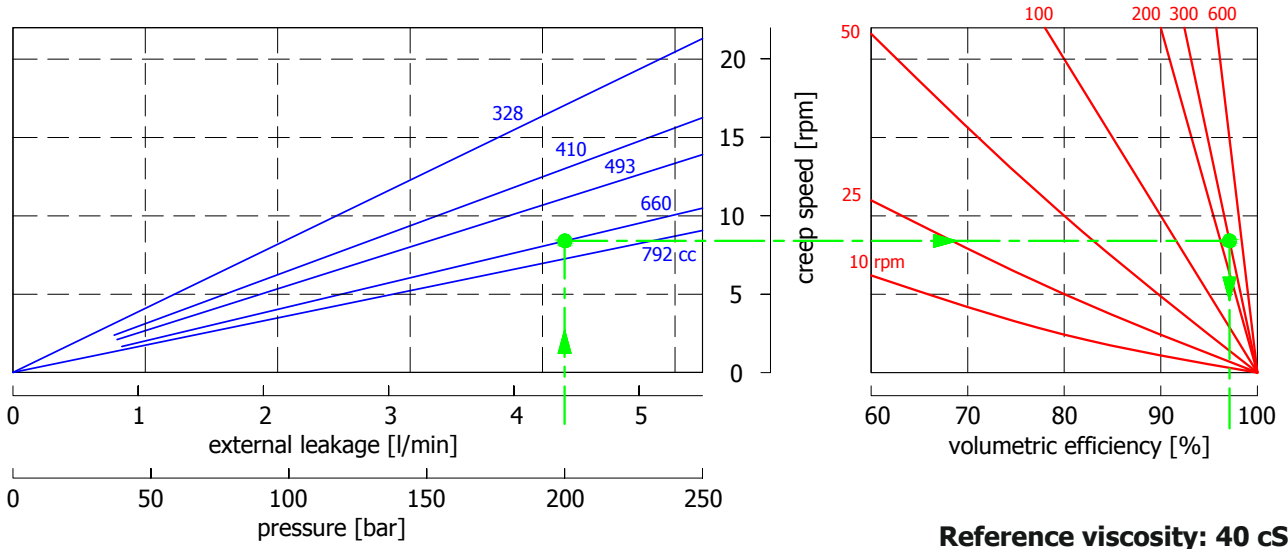

Example:

We suppose (660 cc): $p=200$ [bar], we obtain: external leakage 4,3 [l/min], shaft creep speed 8 [rpm].
If we suppose (660 cc): $p=200$ [bar] and $n=300$ [rpm] we obtain a volumetric efficiency of 97%;

BEARING LIFE

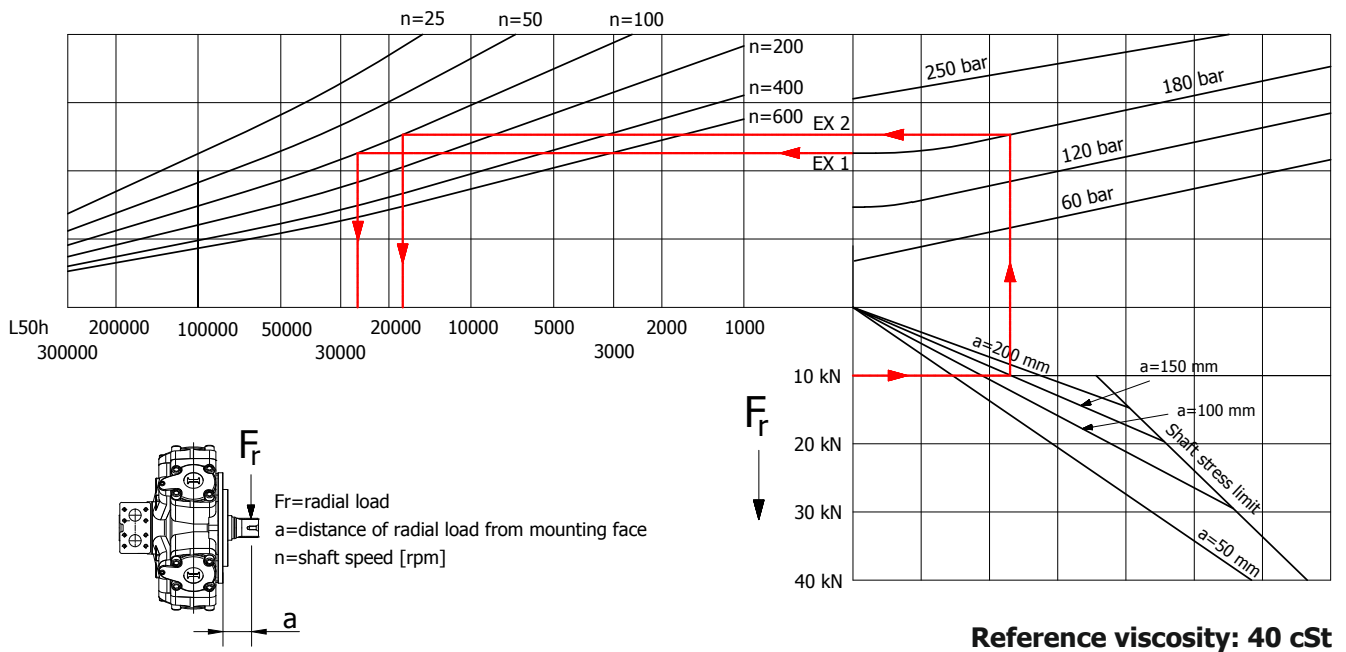

Example:

We suppose (EX1): $p=180$ [bar], $n=100$ [rpm]; we obtain an average lifetime of 33000 [h].
If we suppose (EX2): $F_r=10$ [kN], $a=150$ [mm] and $p=180$ [bar] we obtain an average lifetime of 18000 [h].

The data specified into the catalogue are for product description purpose only and must not be interpreted as warranted characteristics in legal sense. Italgrou S.r.l. reserves the right to implement modifications without notice. All partial or total reproduction and copy without written authorization of Italgrou S.r.l. is strictly forbidden.

ITALGROUP SRL
IAC SERIES - IAC H5
GENERAL CATALOGUE

INDEX - IAC H5

<u>TECHNICAL DATA</u>	Pag	74
<u>IAC 1400 H5 - INSTALLATION DRAWING</u>	“	75
<u>IAC 1400/C H5 - INSTALLATION DRAWING</u>	“	76
<u>IAC 1400/MRH H5 - INSTALLATION DRAWING</u>	“	77
<u>IAC H5 - NIP OPTION</u>	“	78
<u>IAC H5 - CETOP 3 FITTING</u>	“	79
<u>IAC H5 - ORDERING CODE</u>	“	80
<u>IAC 1400 H5 - PERFORMANCE DIAGRAMS</u>	“	82 - 83

IAC 1400 H5 - TECHNICAL DATA

IAC 1400 H5

Displacement (*)	[cc]	1600	1499	1393	1313	1235	1150	1070	980	900	820
Th. specific torque	[Nm/bar]	24,5	23,9	22,2	20,9	19,7	18,3	17	15,6	14,3	13
Continuous speed	[rpm]	370	400	410	435	440	460	480	490	495	520
Peak speed	[rpm]	450	500	500	500	550	550	575	600	600	600
Minimum speed	[rpm]	1	1	1	1	1	1	1	1	1	2
Mechanical efficiency	[%]	94,2	94	93,9	93,7	93,5	93,4	93,2	93	92,6	92,3
Starting efficiency	[%]	88,2	88	86,5	85,3	85,1	82,6	81,3	79,8	77,9	76
Continuous power (***)	[kW]	142	140	135	130	130	125	120	115	110	105
Cont. power with flushing	[kW]	172	170	165	155	155	150	145	138	132	126
Continuous pressure	[bar]	270	270	270	270	270	270	270	270	270	270
Intermittent pressure	[bar]	310	310	310	310	310	310	310	310	310	310
Peak pressure	[bar]	350	350	350	350	350	350	350	350	350	350
Flushing flow	[l/min]	12	12	12	12	12	12	12	12	12	12
Dry weight	[kg]	173	173	173	173	173	173	173	173	173	173

Displacement (*)	[cc]	737	655	574	492	410	328	246	164	82	0
Th. specific torque	[Nm/bar]	11,7	10,4	9,1	7,8	6,5	5,2	3,9	2,6	1,3	0
Continuous speed	[rpm]	545	600	600	600	600	600	600	600	1000	1000
Peak speed	[rpm]	650	700	700	700	800	800	800	800	1200	1500
Minimum speed	[rpm]	2	2	2	2	2	3	3	3	-	-
Mechanical efficiency	[%]	91	89,3	87	83	81,7	75,5	65,7	60,5	0	0
Starting efficiency	[%]	72,9	83,2	65	59,2	51	39	18	0	0	0
Continuous power (***)	[kW]	105	105	95	70	55	40	25	18	0	0
Cont. power with flushing	[kW]	126	126	110	90	75	55	35	22	0	0
Continuous pressure	[bar]	250	250	250	250	250	250	250	250	17(**)	17(**)
Intermittent pressure	[bar]	310	310	310	310	310	310	310	310	17(**)	17(**)
Peak pressure	[bar]	350	350	350	350	350	350	350	350	17(**)	17(**)
Flushing flow	[l/min]	12	12	12	12	12	12	12	12	15	15
Dry weight	[kg]	173	173	173	173	173	173	173	173	173	173

(*) Different displacements can be available on request. Please contact ItalgrouP S.r.l. for more information.

(**) Pressure limits at 1000 rpm. For lower speeds the values can be increased. Contact ItalgrouP for more information.

(***) The continuous power and the continuous power with flushing are the output maximum power. To estimate the input power divide the output power by the mechanical efficiency. For example: if required output power is 120 kW and starting efficiency is 88,2%, estimated required power is $120/0.882 = 136$ kW.

Hydrostatic pressure test: 420 bar.

Temperature range: -30 / 70 °C.

IAC 1400 H5 - INSTALLATION DRAWING

XY DISPLACEMENT CHANGE CONFIGURATION

X - minimum displacement
Y - maximum displacement

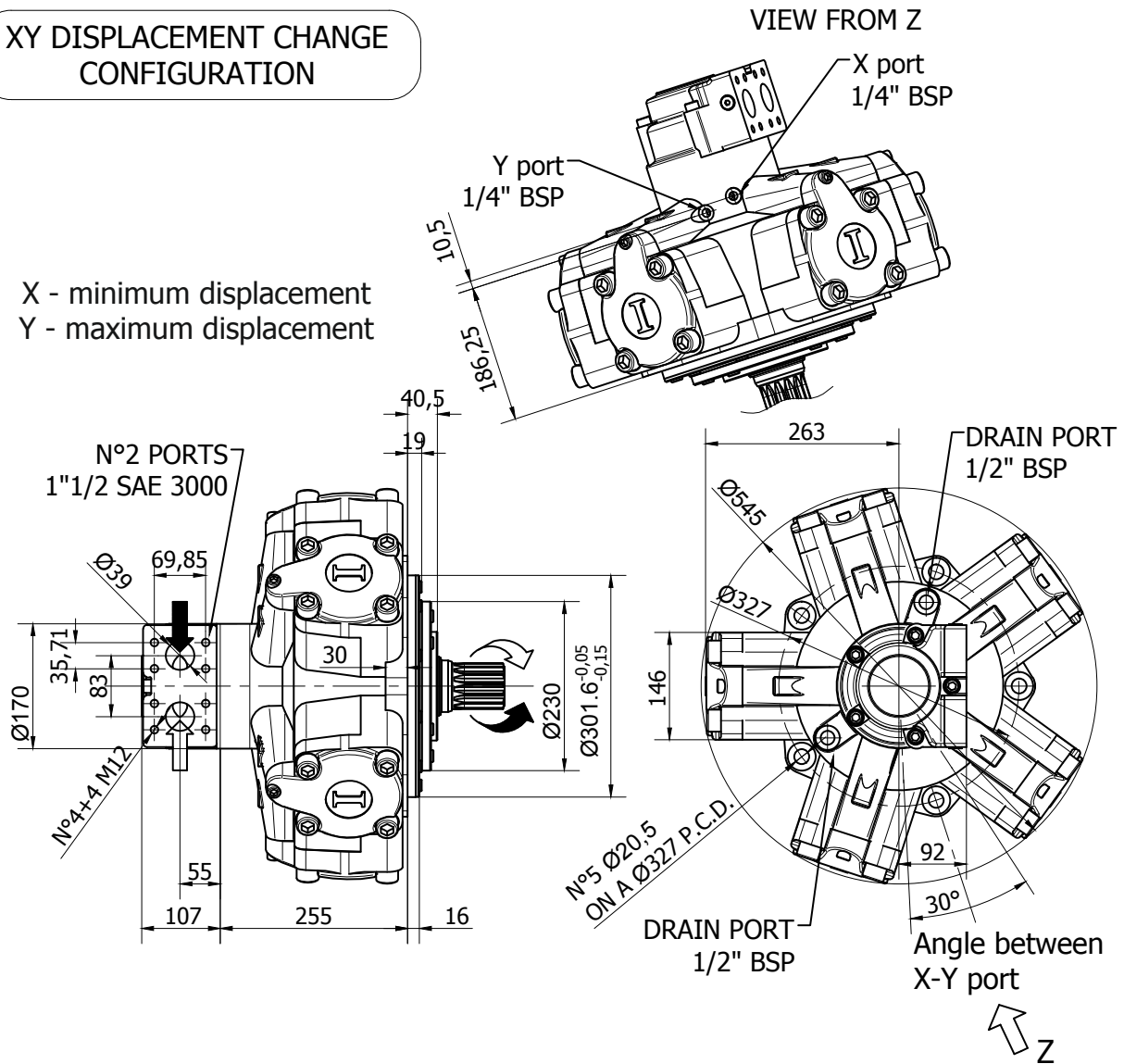

SHAFT TYPE: A0

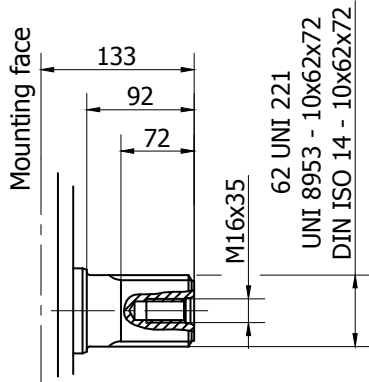

SHAFT TYPE: A1

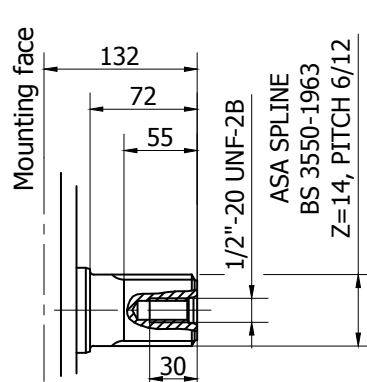

SHAFT TYPE: A2

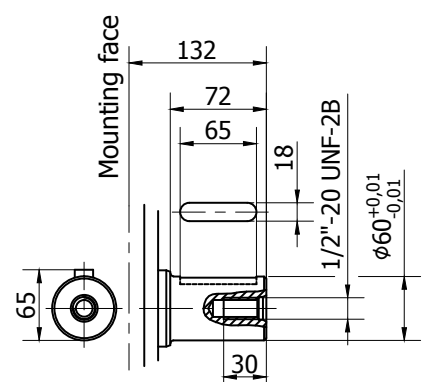

The data specified into the catalogue are for product description purpose only and must not be interpreted as warranted characteristics in legal sense. Italgrou S.r.l. reserves the right to implement modifications without notice. All partial or total reproduction and copy without written authorization of Italgrou S.r.l. is strictly forbidden.

XY DISPLACEMENT CHANGE CONFIGURATION

X - minimum displacement
Y - maximum displacement

VIEW FROM Z

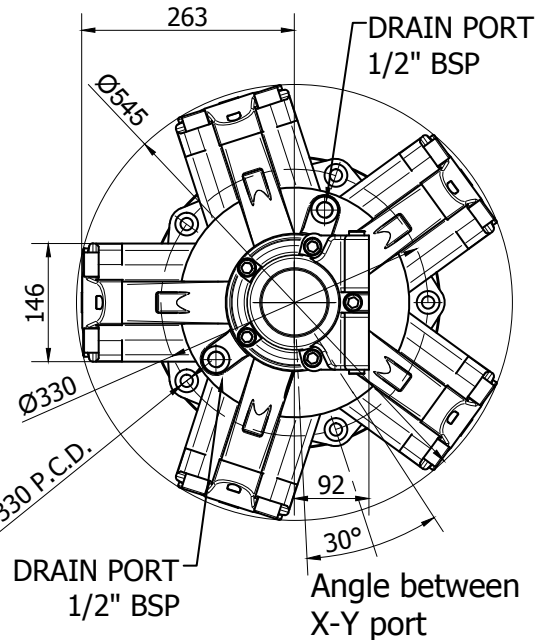
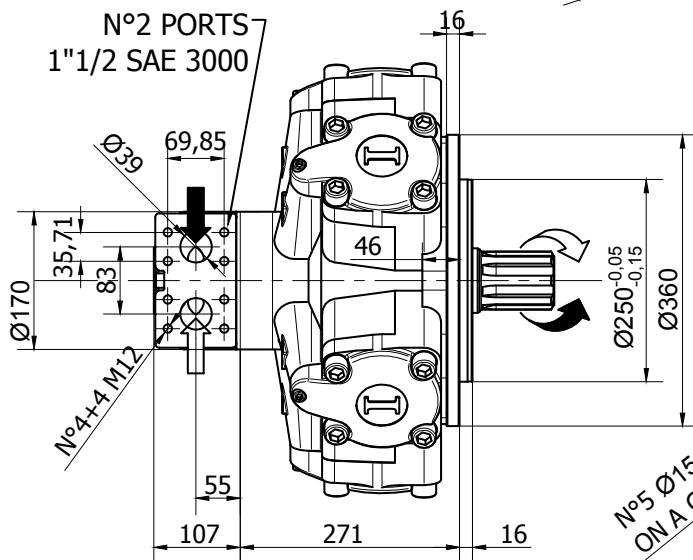
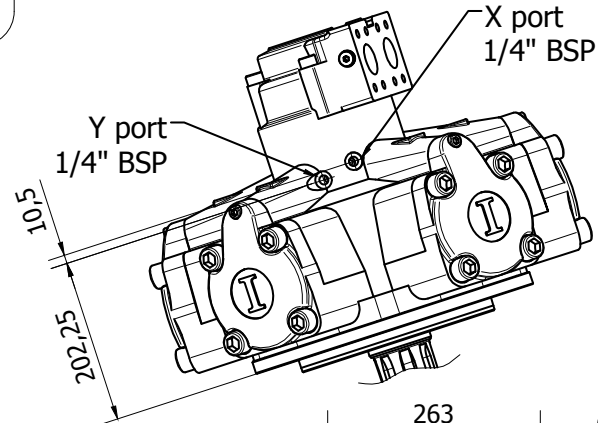

SHAFT TYPE: A0

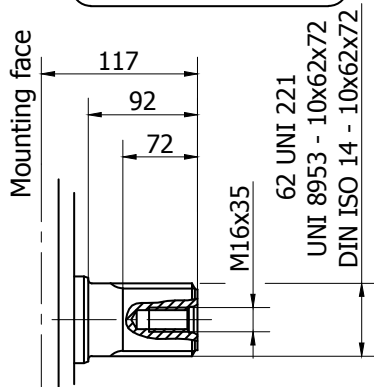

SHAFT TYPE: A3

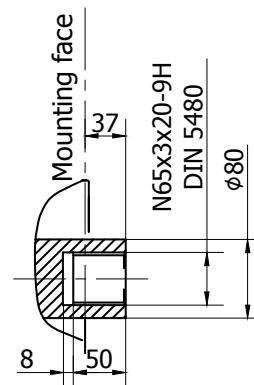

The data specified into the catalogue are for product description purpose only and must not be interpreted as warranted characteristics in legal sense. Italgrou S.r.l. reserves the right to implement modifications without notice. All partial or total reproduction and copy without written authorization of Italgrou S.r.l. is strictly forbidden.

IAC 1400/MRH H5 - INSTALLATION DRAWING



HYDRAULIC MOTORS
ITALY

XY DISPLACEMENT CHANGE CONFIGURATION

X - minimum displacement
Y - maximum displacement

VIEW FROM Z

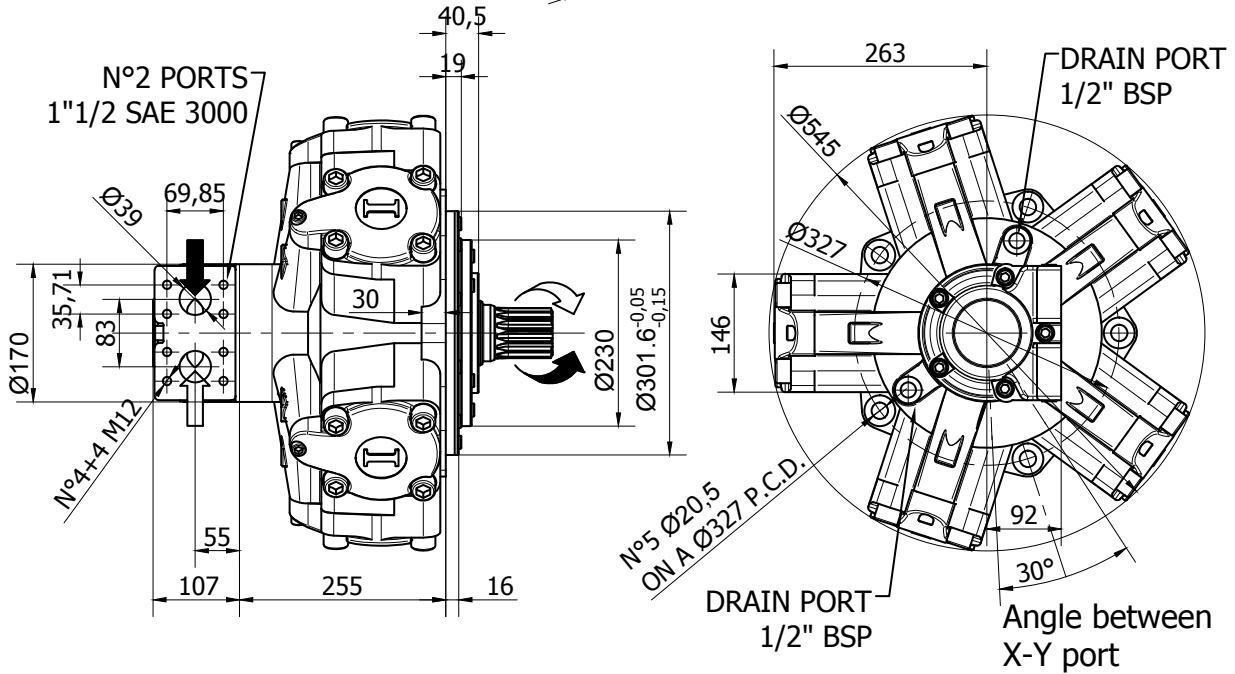
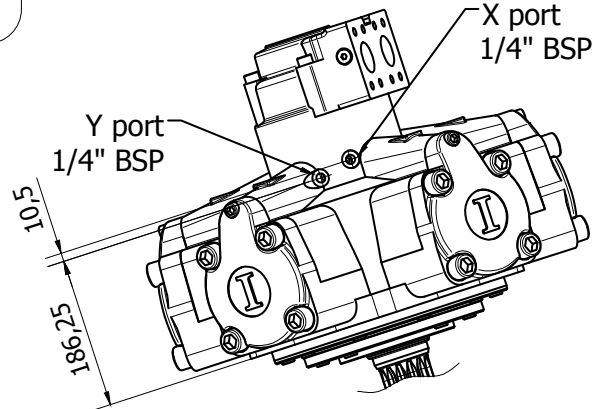

SHAFT TYPE: A1

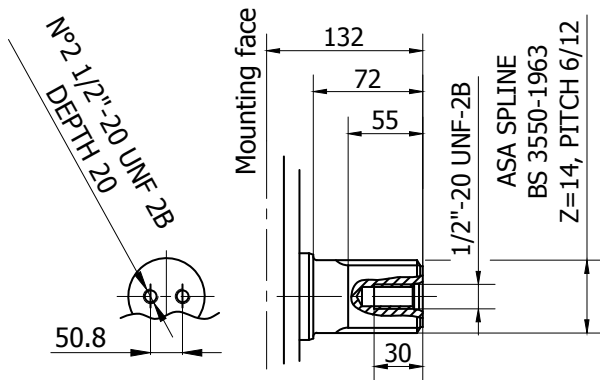

The data specified into the catalogue are for product description purpose only and must not be interpreted as warranted characteristics in legal sense. ItalgrouP S.r.l. reserves the right to implement modifications without notice. All partial or total reproduction and copy without written authorization of ItalgrouP S.r.l. is strictly forbidden.

**XY DISPLACEMENT CHANGE
 CONFIGURATION**

X - minimum displacement
 Y - maximum displacement

VIEW FROM Z

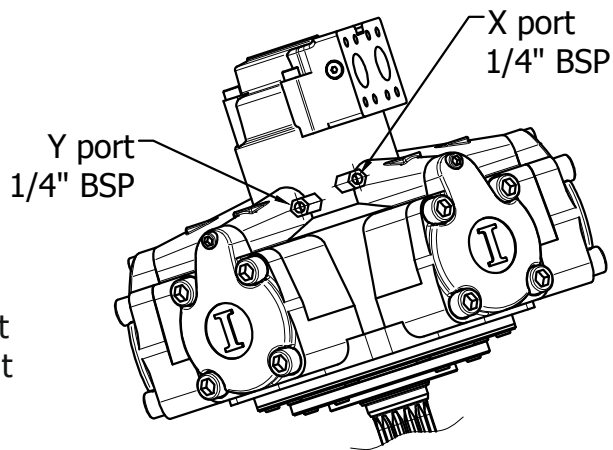

83 (standard version)
 123 (NIP version)

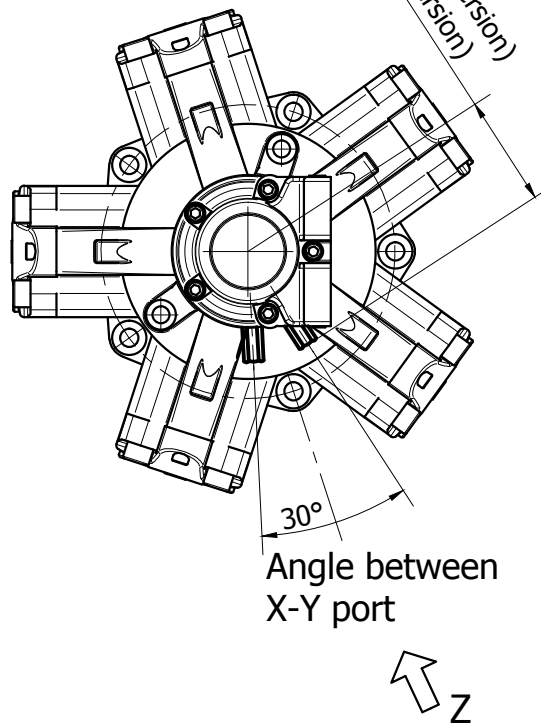
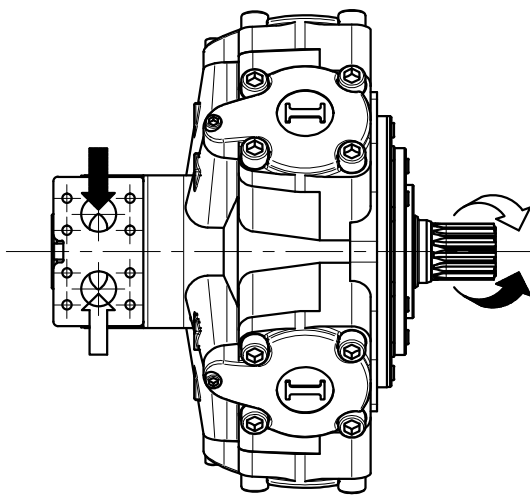

30°
 Angle between
 X-Y port

The data specified into the catalogue are for product description purpose only and must not be interpreted as warranted characteristics in legal sense. Italgrou**S.r.l.** reserves the right to implement modifications without notice. All partial or total reproduction and copy without written authorization of Italgrou**S.r.l.** is strictly forbidden.

IAC 1400 H5 - CETOP 3 FITTING

CETOP 3 DISPLACEMENT CHANGE CONFIGURATION

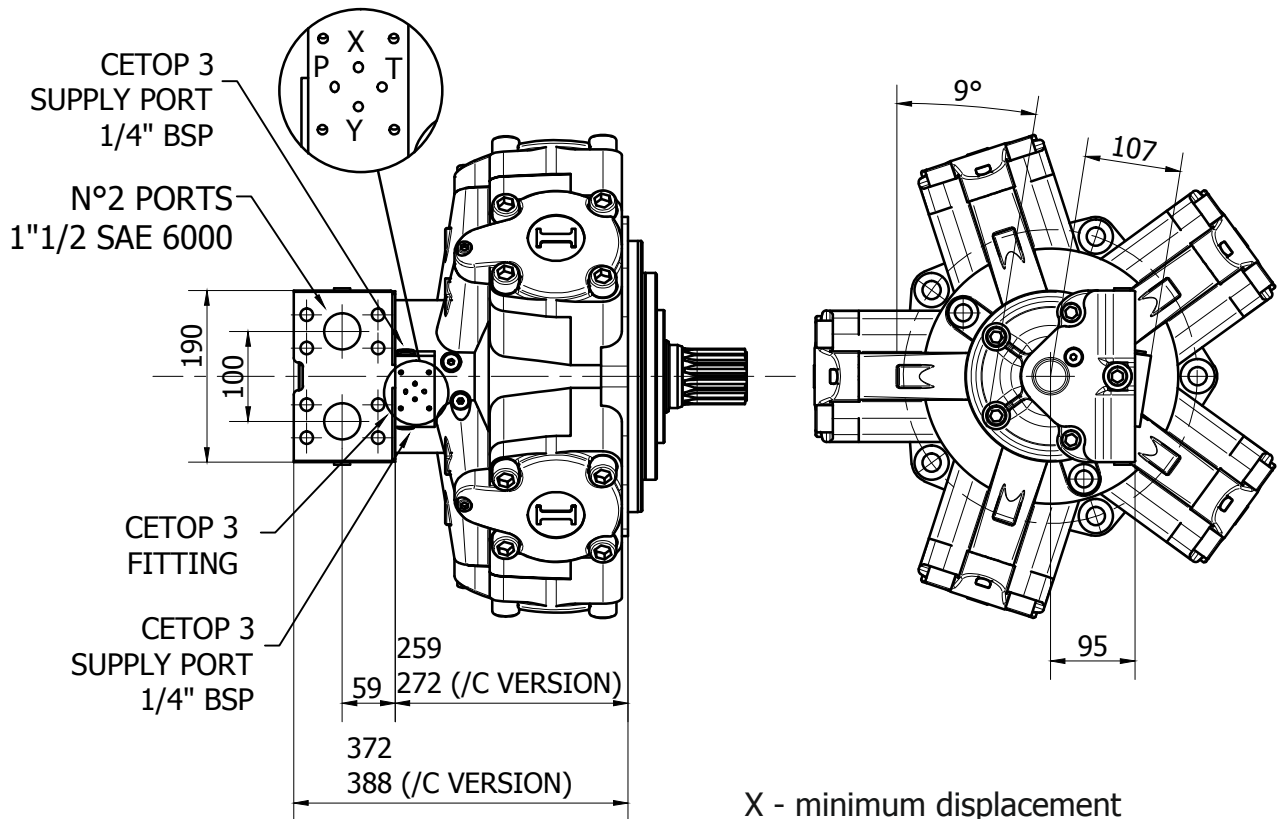

X - minimum displacement
Y - maximum displacement

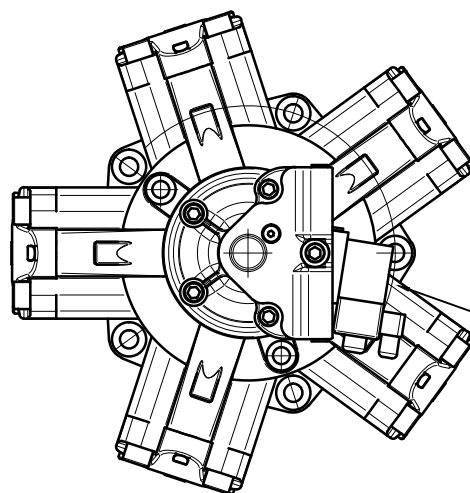

CETOP 3 DISPLACEMENT CHANGE VALVE

- C3 - 12 SV (12V DC)
- C3 - 24 SV (24V DC)
- C3 - HY SV (HYDRAULIC OPERATED)

IAC 1400 H5 - ORDERING CODE

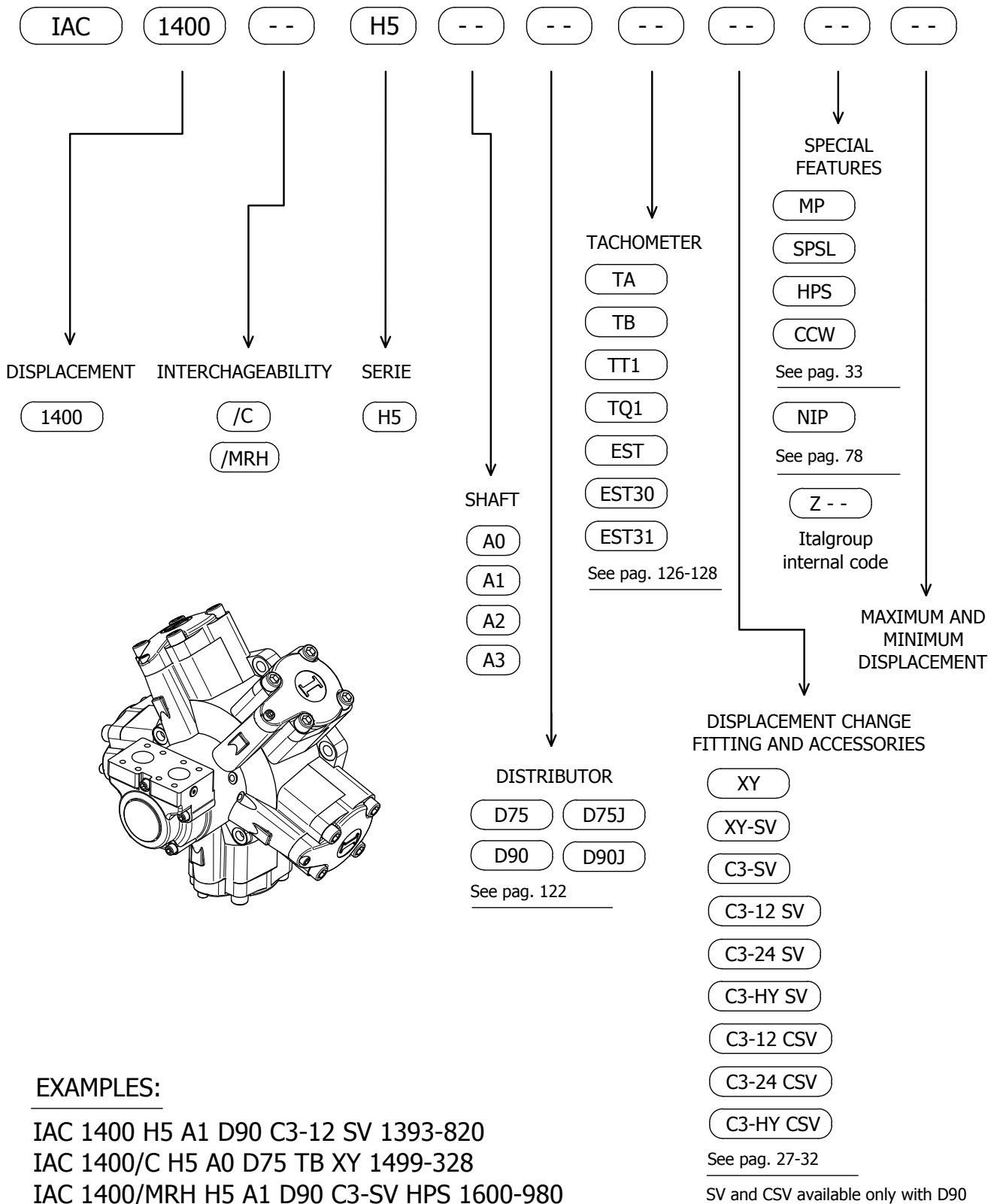

The data specified into the catalogue are for product description purpose only and must not be interpreted as warranted characteristics in legal sense. Italgrou S.r.l. reserves the right to implement modifications without notice. All partial or total reproduction and copy without written authorization of Italgrou S.r.l. is strictly forbidden.

The data specified into the catalogue are for product description purpose only and must not be interpreted as warranted characteristics in legal sense. Italgroup S.r.l. reserves the right to implement modifications without notice. All partial or total reproduction and copy without written authorization of Italgroup S.r.l. is strictly forbidden.

1536 cc - WITHOUT FLUSHING

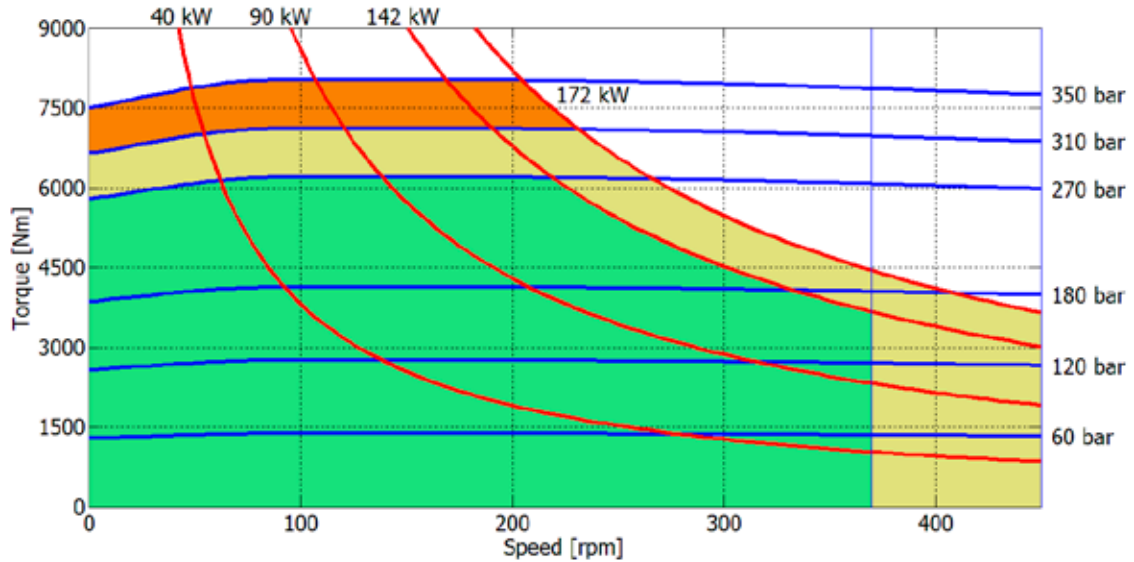

737 cc - WITHOUT FLUSHING

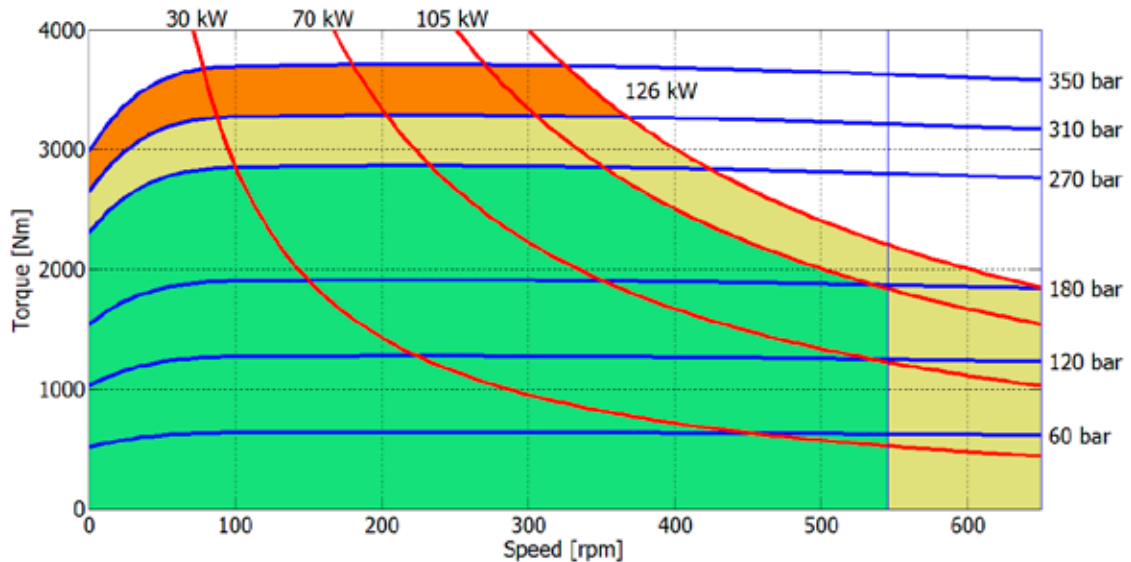

Continuous operation



Intermittent operation: permitted for a 15% of duty cycle, for 3 minutes maximum period.



Peak operation: permitted for very short periods (3-5 seconds every 10-15 minutes).

The above diagrams are referring to the hydraulic motor working with a fluid in ideal conditions (viscosity at 40 cSt). In case the working temperature increases and viscosity reach values under the recommended values (see hydraulic fluid recommendations) flushing must be performed or ISO oil grade must be changed. The working temperature must not overcome 70 °C.

The data specified into the catalogue are for product description purpose only and must not be interpreted as warranted characteristics in legal sense. Italgrou S.r.l. reserves the right to implement modifications without notice. All partial or total reproduction and copy without written authorization of Italgrou S.r.l. is strictly forbidden.

1536 cc - WITH FLUSHING

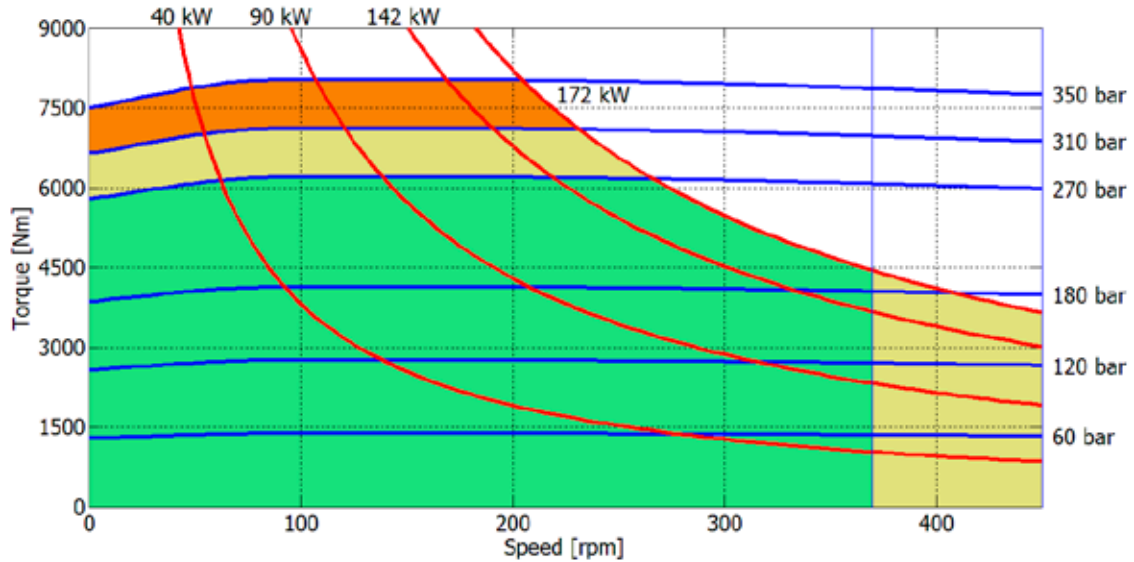

737 cc - WITH FLUSHING

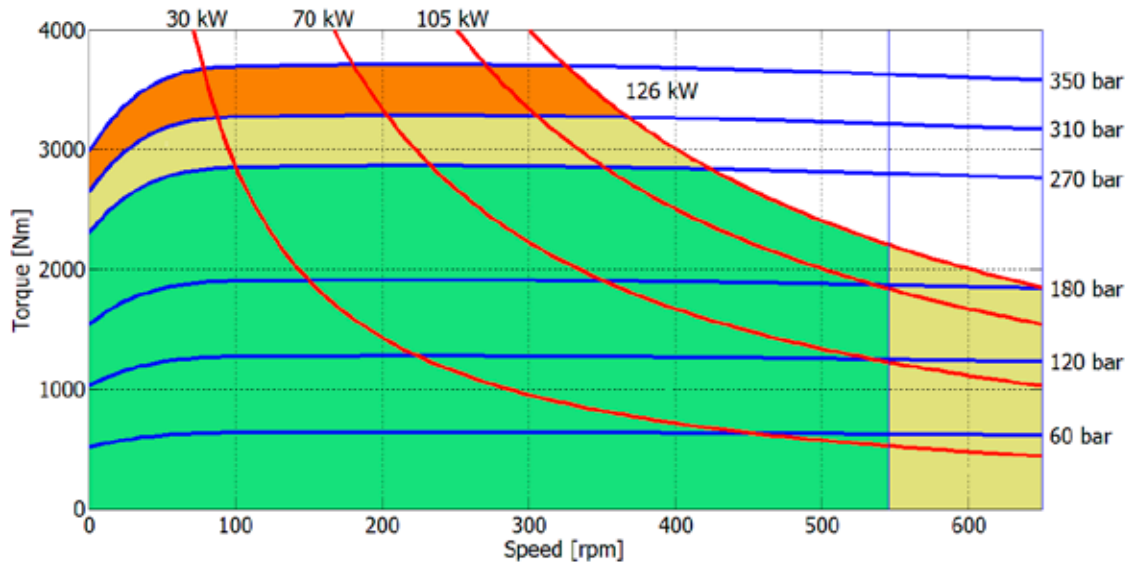

- Continuous operation
- Intermittent operation: permitted for a 15% of duty cycle, for 3 minutes maximum period.
- Peak operation: permitted for very short periods (3-5 seconds every 10-15 minutes).

The above diagrams are referring to the hydraulic motor working with a fluid in ideal conditions (viscosity at 40 cSt). In case the working temperature increases and viscosity reach values under the recommended values (see hydraulic fluid recommendations) flushing must be optimized or ISO oil grade must be changed. The working temperature must not overcome 70 °C.

The data specified into the catalogue are for product description purpose only and must not be interpreted as warranted characteristics in legal sense. ItalgrouP S.r.l. reserves the right to implement modifications without notice. All partial or total reproduction and copy without written authorization of ItalgrouP S.r.l. is strictly forbidden.

CREEP SPEED - VOLUMETRIC EFFICIENCY

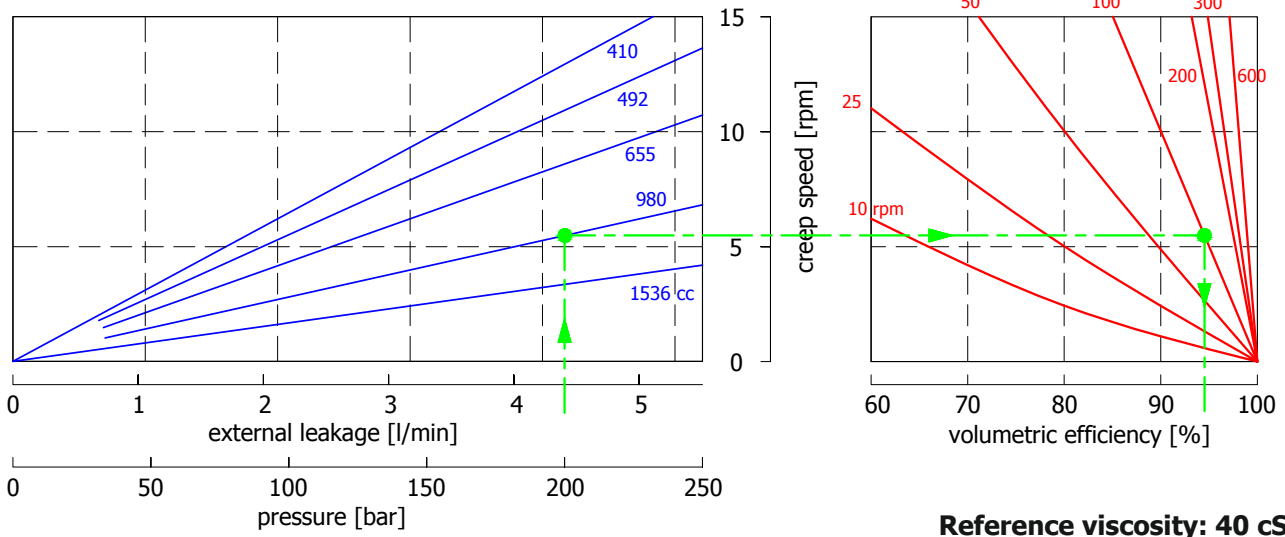

Example:

We suppose (980 cc): $p=200$ [bar], we obtain: external leakage 4,3 [l/min], shaft creep speed 5,5 [rpm].
If we suppose (980 cc): $p=200$ [bar] and $n=100$ [rpm] we obtain a volumetric efficiency of 94,5%;

BEARING LIFE

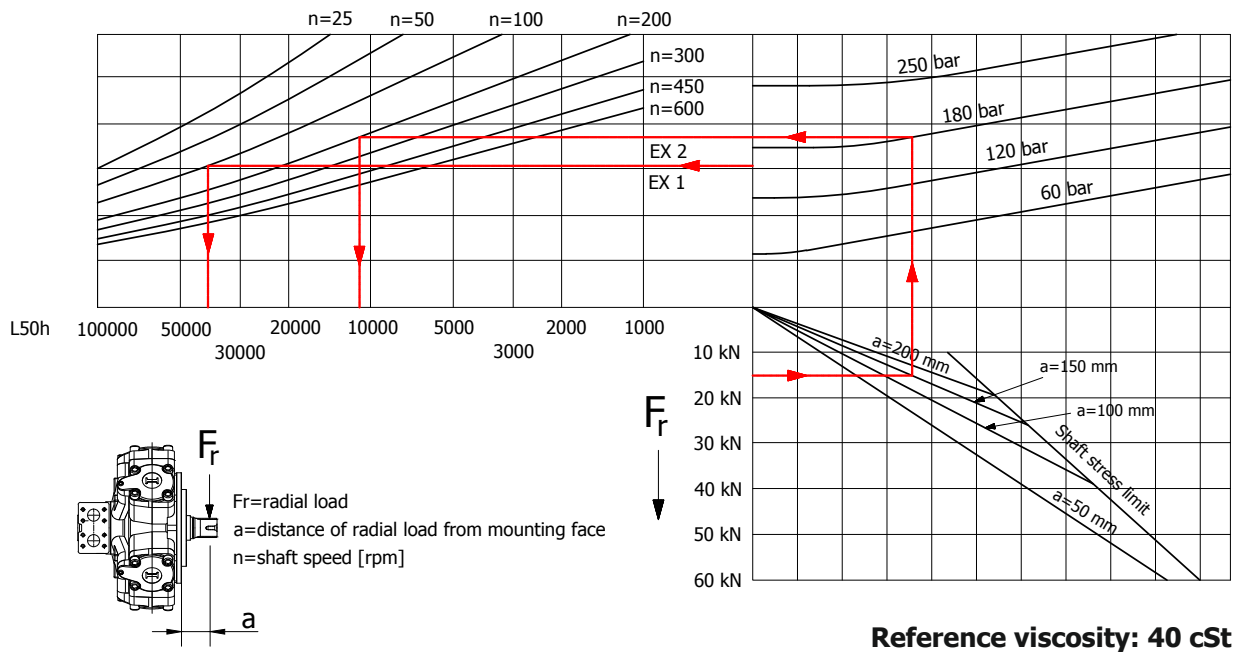

Example:

We suppose (EX1): $p=180$ [bar], $n=100$ [rpm]; we obtain an average lifetime of 40000 [h].
If we suppose (EX2): $F_r=15$ [kN], $a=150$ [mm], $n=200$ [rpm] and $p=180$ [bar] we obtain an average lifetime of 11000 [h].

The data specified into the catalogue are for product description purpose only and must not be interpreted as warranted characteristics in legal sense. Italgrou S.r.l. reserves the right to implement modifications without notice. All partial or total reproduction and copy without written authorization of Italgrou S.r.l. is strictly forbidden.

ITALGROUP SRL
IAC SERIES - IAC H55
GENERAL CATALOGUE

INDEX - IAC H55

TECHNICAL DATA	Pag	86
IAC 2200 H55 - INSTALLATION DRAWING	“	87
IAC 2200/MRH H55 - INSTALLATION DRAWING	“	88
IAC H55 - NIP OPTION	“	89
IAC H55 - CETOP 3 FITTING	“	90
IAC H55 - ORDERING CODE	“	91
IAC 2200 H55 - PERFORMANCE DIAGRAMS	“	92 - 94

IAC 2200 H55

Displacement (*)	[cc]	2200	2049	1970	1800	1640	1470	1310	1150	980	820
Th. specific torque	[Nm/bar]	35	32,6	31,3	28,6	26,1	23,4	20,9	18,3	15,6	13,1
Continuous speed	[rpm]	280	305	320	350	380	410	440	470	610	620
Peak speed	[rpm]	320	340	360	400	430	470	500	540	700	700
Minimum speed	[rpm]	1	1	1	1	1	1	1	1	1	2
Mechanical efficiency	[%]	92,2	92,2	92,2	92,2	91	90	88	86,5	82,2	81,8
Starting efficiency	[%]	81	80,6	79,6	77,5	74,6	71,5	67,5	62,2	55,3	45,8
Continuous power (***)	[kW]	140	140	135	125	116	108	100	90	83	75
Cont. power with flushing	[kW]	170	170	165	155	145	135	127	110	105	90
Continuous pressure	[bar]	270	270	270	270	270	270	270	270	270	250
Intermittent pressure	[bar]	310	310	310	310	310	310	310	310	310	310
Peak pressure	[bar]	350	350	350	350	350	350	350	350	350	350
Flushing flow	[l/min]	10	10	10	10	10	10	10	10	10	10
Dry weight	[kg]	210	210	210	210	210	210	210	210	210	210

Displacement (*)	[cc]	655	490	330	160	82	0
Th. specific torque	[Nm/bar]	10,4	7,8	5,3	2,5	1,3	0
Continuous speed	[rpm]	620	640	640	640	1000	1000
Peak speed	[rpm]	720	720	800	800	1200	1500
Minimum speed	[rpm]	2	2	3	5	-	-
Mechanical efficiency	[%]	78,2	76	73	26	0	0
Starting efficiency	[%]	31,5	0	0	0	0	0
Continuous power (***)	[kW]	65	50	25	5	0	0
Cont. power with flushing	[kW]	80	65	40	10	0	0
Continuous pressure	[bar]	250	250	250	250	17(**)	17(**)
Intermittent pressure	[bar]	310	310	310	310	17(**)	17(**)
Peak pressure	[bar]	350	350	350	350	17(**)	17(**)
Flushing flow	[l/min]	10	10	10	12	15	15
Dry weight	[kg]	210	210	210	210	210	210

(*) Different displacements can be available on request. Please contact ItalgrouP S.r.l. for more information.

(**) Pressure limits at 1000 rpm. For lower speeds the values can be increased. Contact ItalgrouP for more information.

(***) The continuous power and the continuous power with flushing are the output maximum power. To estimate the input power divide the output power by the mechanical efficiency. For example: if required output power is 150 kW and starting efficiency is 86%, estimated required power is $150/0.86 = 174,4$ kW.

Hydrostatic pressure test: 420 bar.

Temperature range: -30 / 70 °C.

IAC 2200 H55 - INSTALLATION DRAWING

XY DISPLACEMENT CHANGE CONFIGURATION

X - minimum displacement
Y - maximum displacement

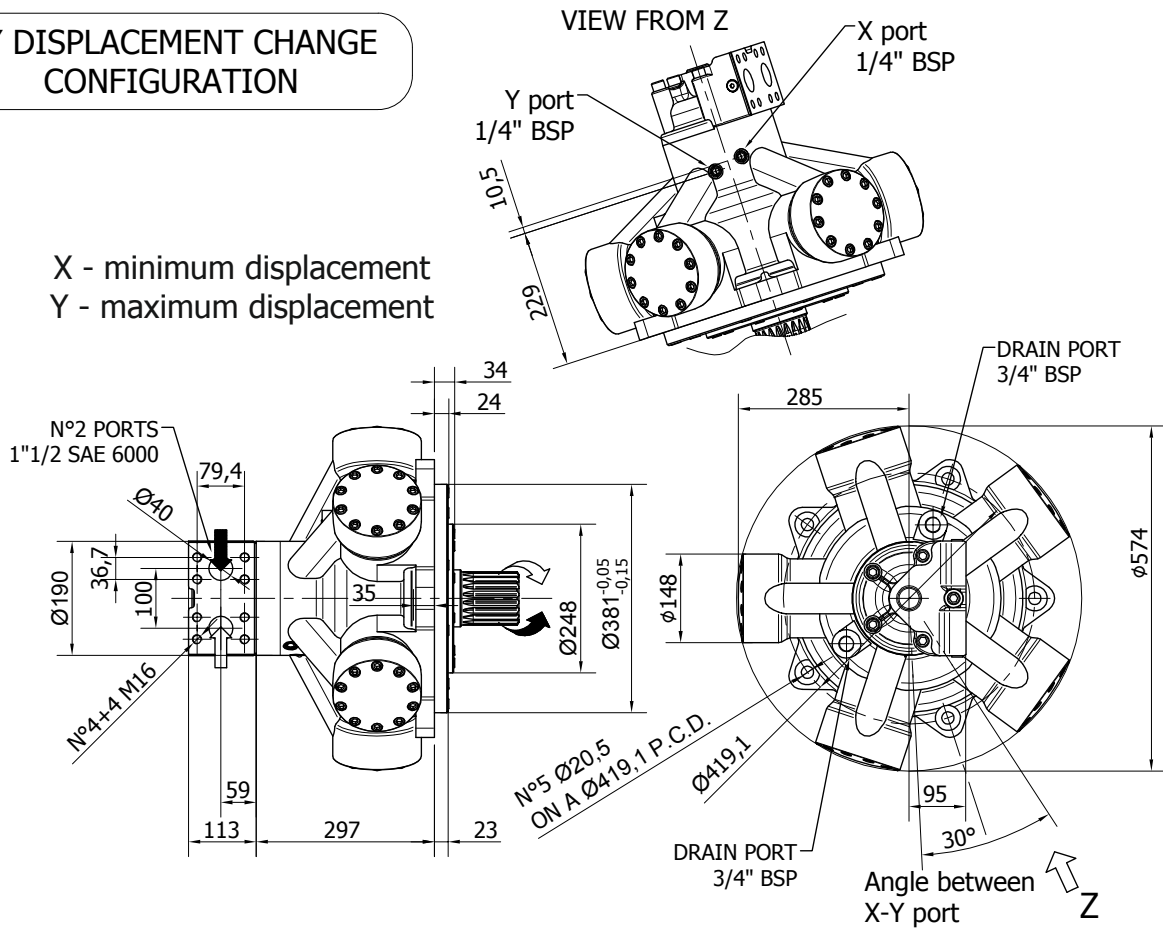

SHAFT TYPE: A0

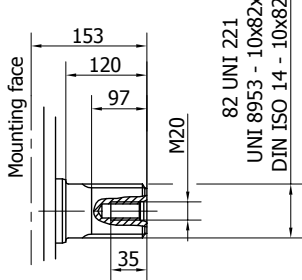

SHAFT TYPE: A1

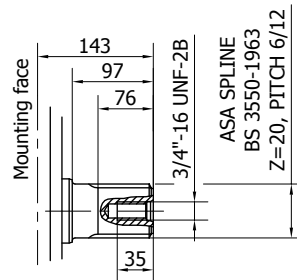

SHAFT TYPE: A2

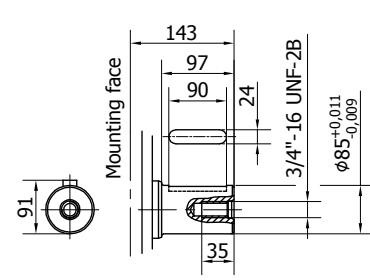

SHAFT TYPE: A11

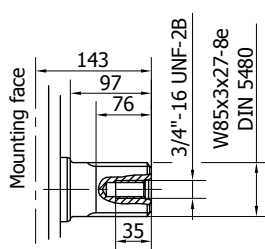

SHAFT TYPE: A4

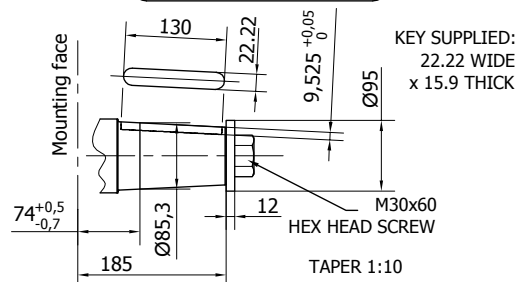

The data specified into the catalogue are for product description purpose only and must not be interpreted as warranted characteristics in legal sense. ItalgrouP S.r.l. reserves the right to implement modifications without notice. All partial or total reproduction and copy without written authorization of ItalgrouP S.r.l. is strictly forbidden.

XY DISPLACEMENT CHANGE CONFIGURATION

X - minimum displacement
Y - maximum displacement

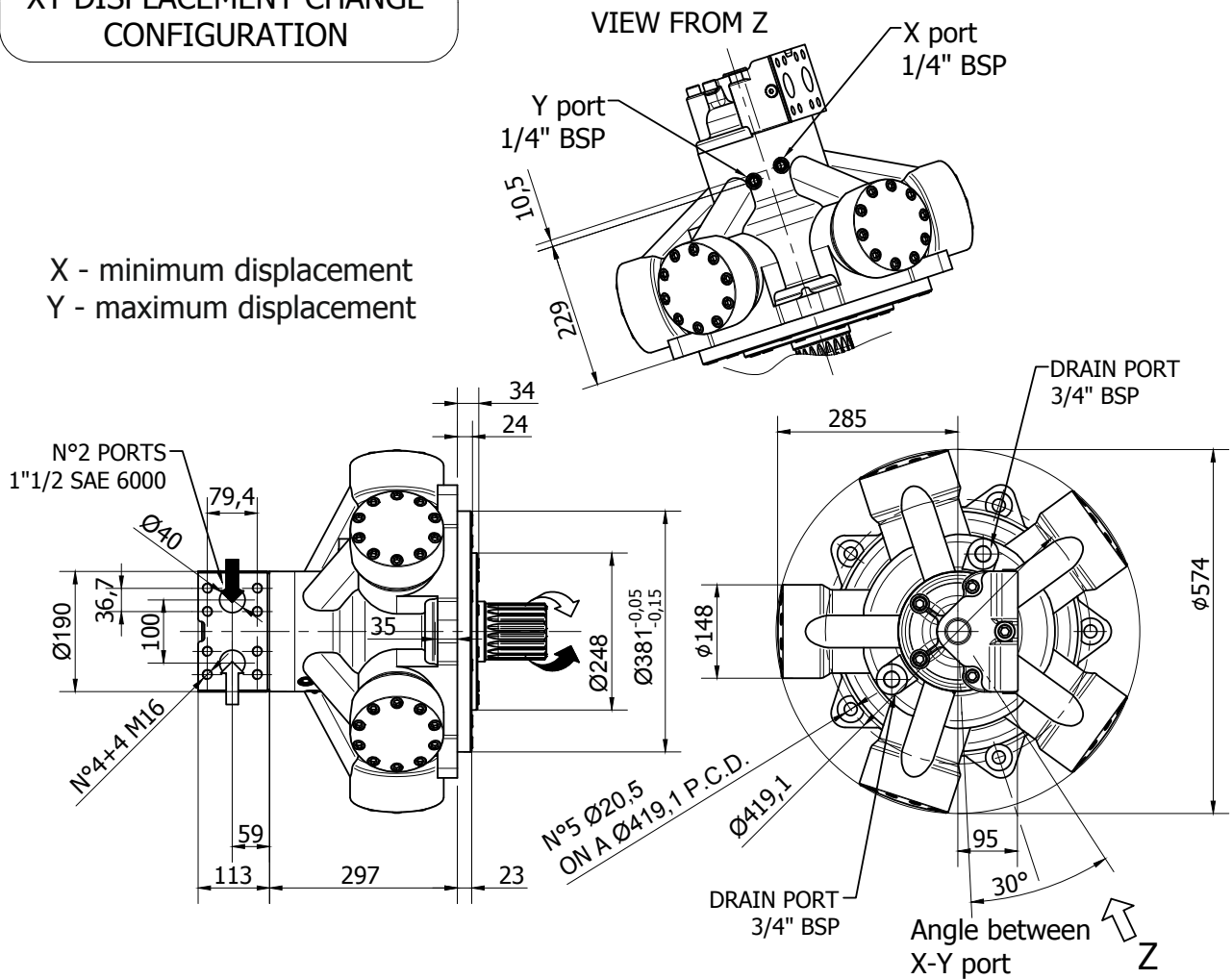

SHAFT TYPE: A12

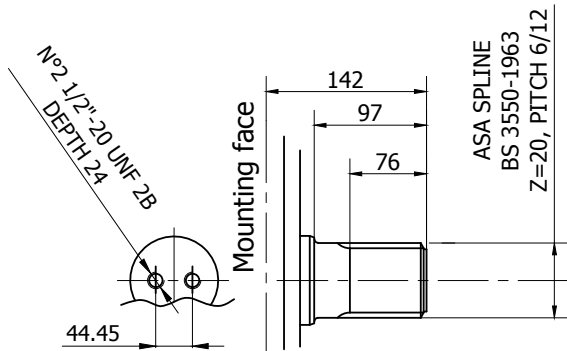

SHAFT TYPE: A4

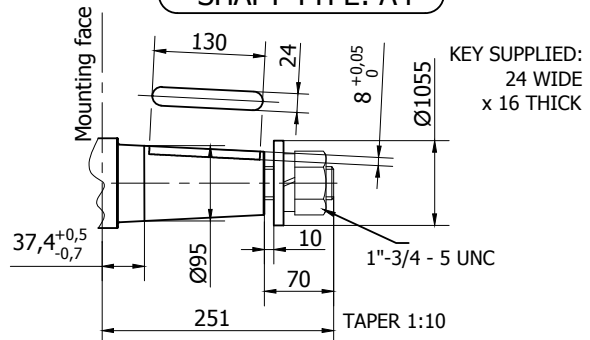

The data specified into the catalogue are for product description purpose only and must not be interpreted as warranted characteristics in legal sense. Italgrou S.r.l. reserves the right to implement modifications without notice. All partial or total reproduction and copy without written authorization of Italgrou S.r.l. is strictly forbidden.

XY DISPLACEMENT CHANGE
CONFIGURATION

VIEW FROM Z

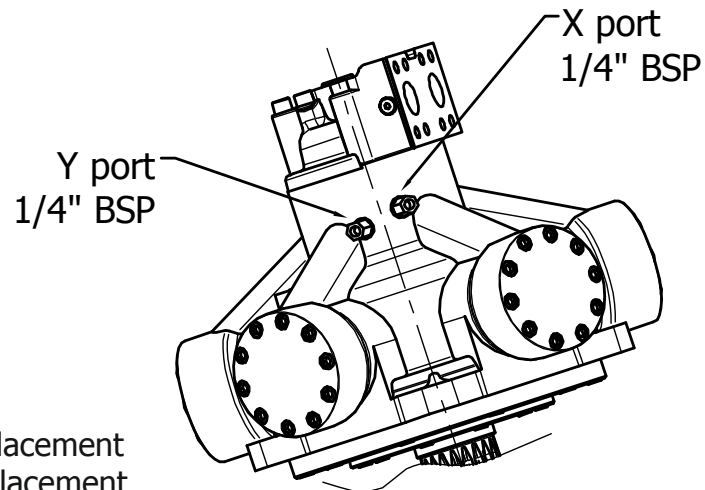

X - minimum displacement
Y - maximum displacement

93 (Standard version)
133 (NIP version)

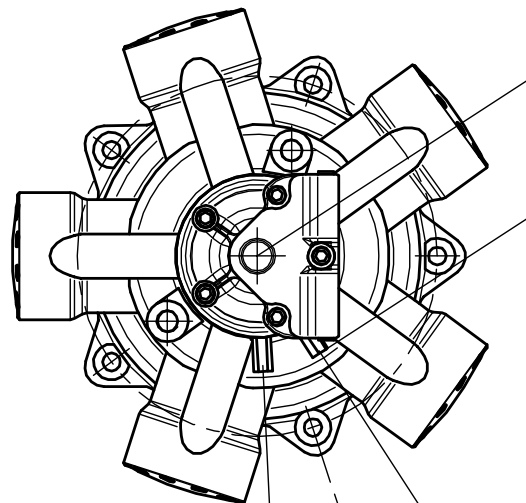
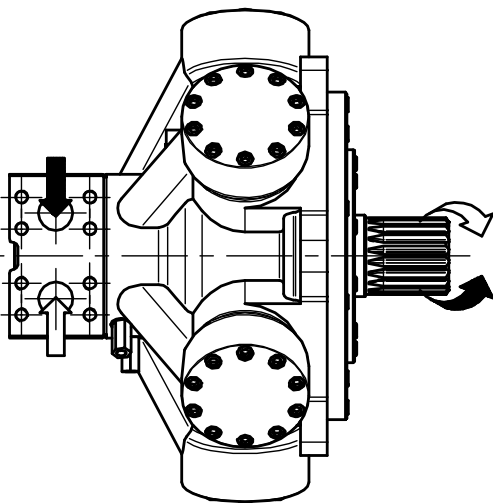

30°
Angle between
X-Y port

The data specified into the catalogue are for product description purpose only and must not be interpreted as warranted characteristics in legal sense. ItalgrouP S.r.l. reserves the right to implement modifications without notice. All partial or total reproduction and copy without written authorization of ItalgrouP S.r.l. is strictly forbidden.

**CETOP 3 DISPLACEMENT
CHANGE CONFIGURATION**

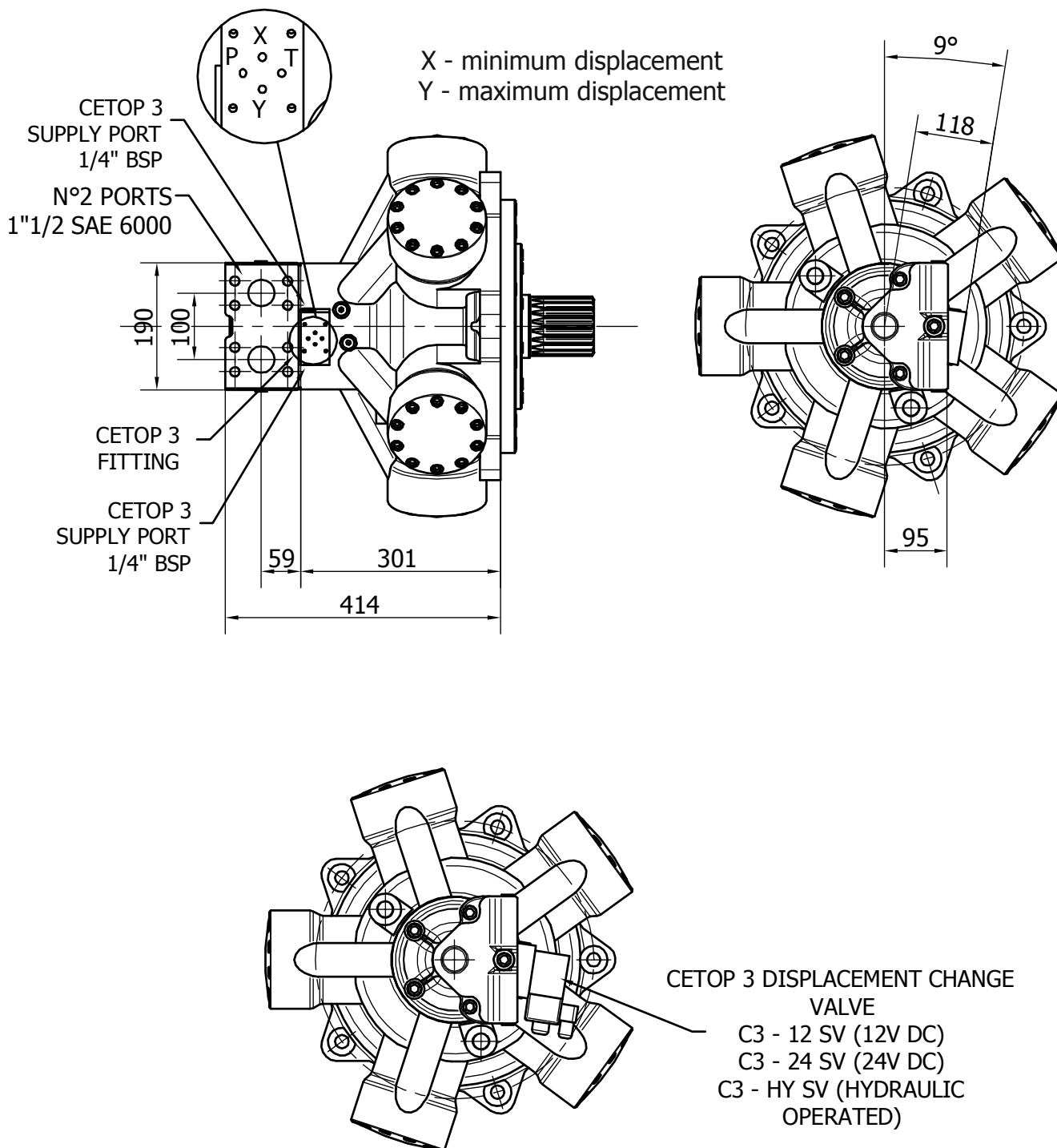

The data specified into the catalogue are for product description purpose only and must not be interpreted as warranted characteristics in legal sense. Italgroup S.r.l. reserves the right to implement modifications without notice. All partial or total reproduction and copy without written authorization of Italgroup S.r.l. is strictly forbidden.

IAC 2200 H55 - ORDERING CODE

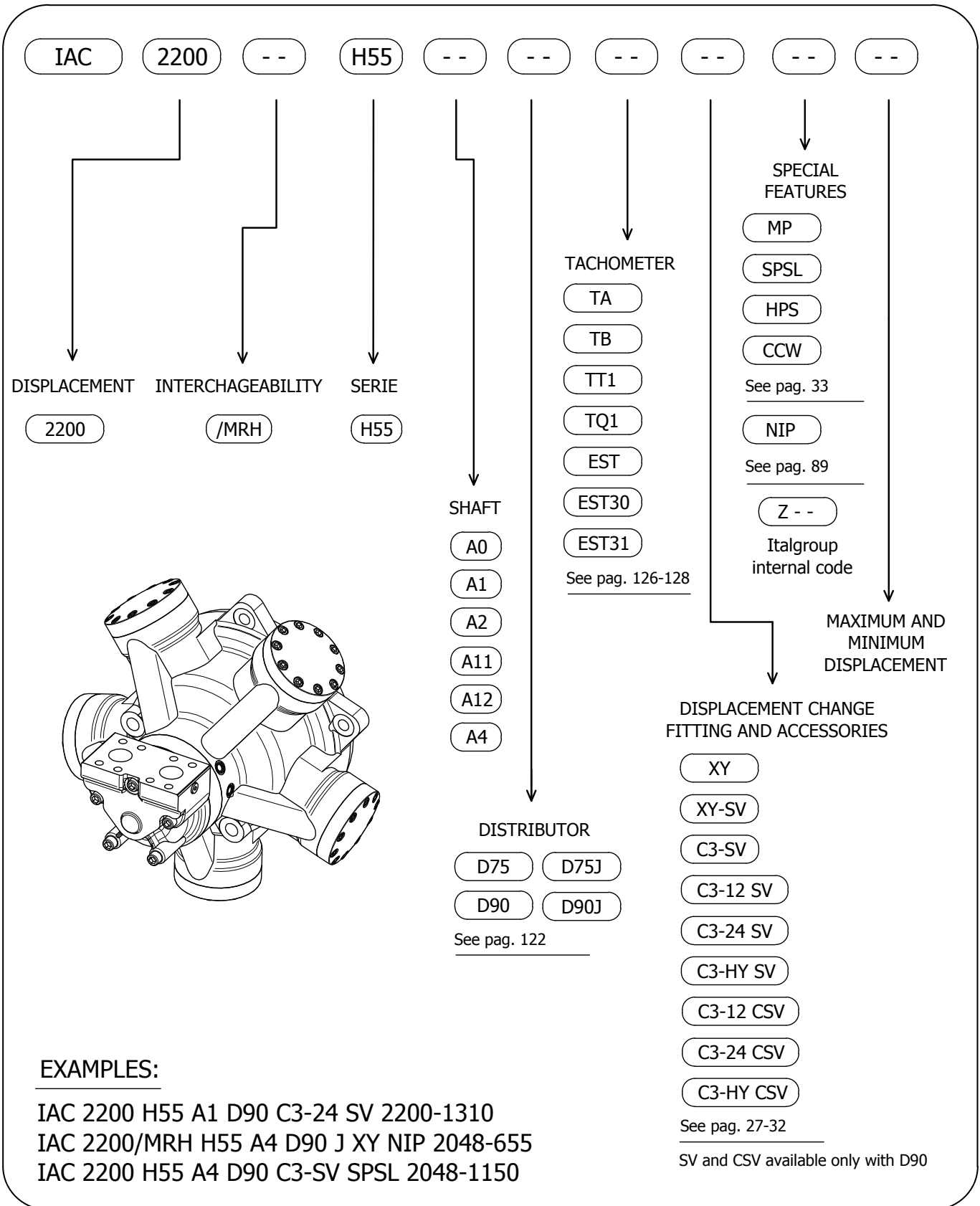

The data specified into the catalogue are for product description purpose only and must not be interpreted as warranted characteristics in legal sense. Italgroup S.r.l. reserves the right to implement modifications without notice. All partial or total reproduction and copy without written authorization of Italgroup S.r.l. is strictly forbidden.

2200 cc - WITHOUT FLUSHING

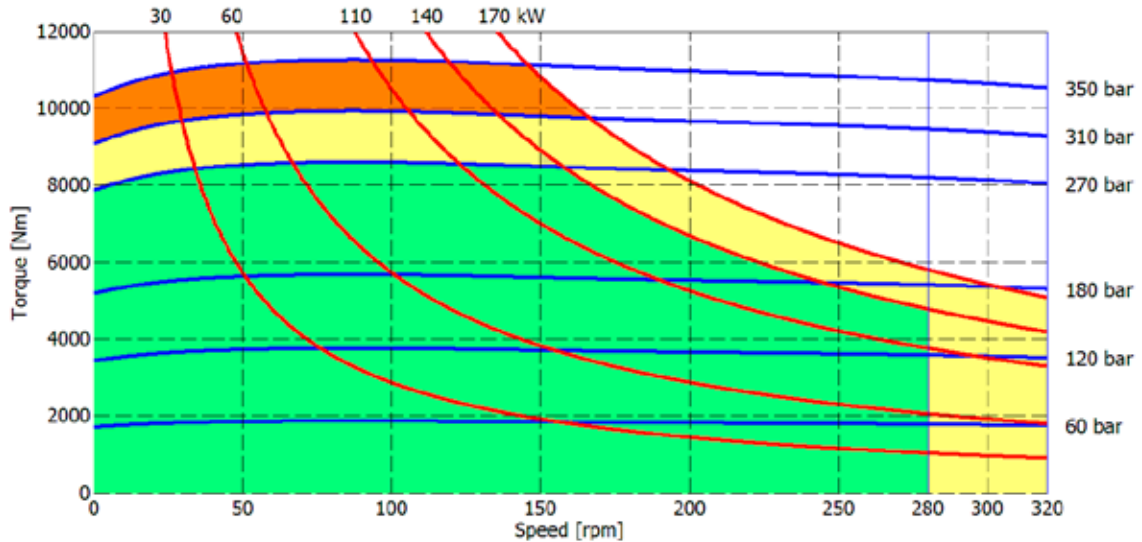

1150 cc - WITHOUT FLUSHING

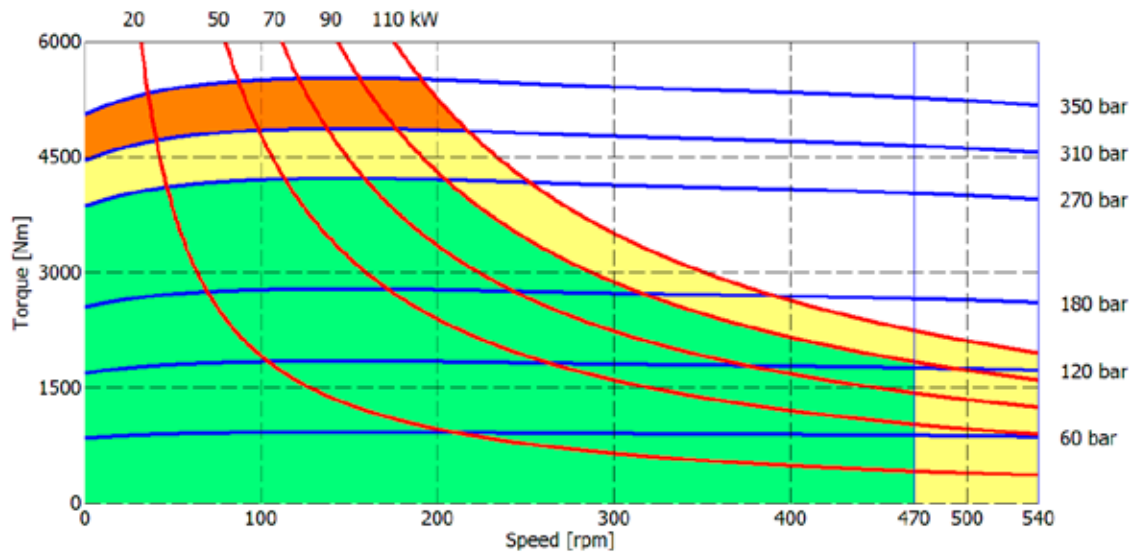

- Continuous operation
- Intermittent operation: permitted for a 15% of duty cycle, for 3 minutes maximum period.
- Peak operation: permitted for very short periods (3-5 seconds every 10-15 minutes).

The above diagrams are referring to the hydraulic motor working with a fluid in ideal conditions (viscosity at 40 cSt). In case the working temperature increases and viscosity reach values under the recommended values (see hydraulic fluid recommendations) flushing must be performed or ISO oil grade must be changed. The working temperature must not overcome 70 °C.

The data specified into the catalogue are for product description purpose only and must not be interpreted as warranted characteristics in legal sense. Italgrou S.r.l. reserves the right to implement modifications without notice. All partial or total reproduction and copy without written authorization of Italgrou S.r.l. is strictly forbidden.

2200 cc - WITH FLUSHING

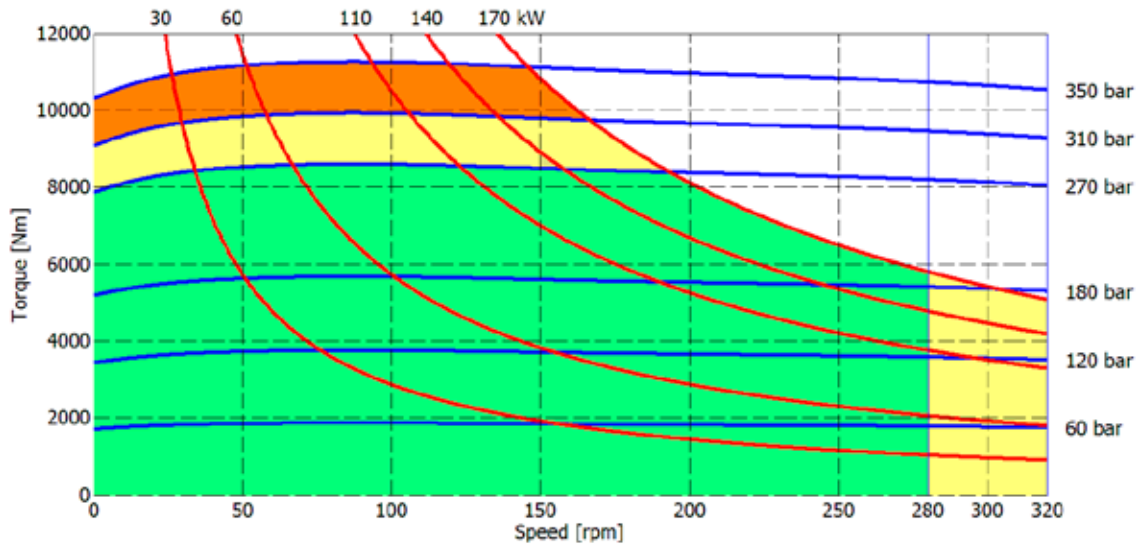

1150 cc - WITH FLUSHING

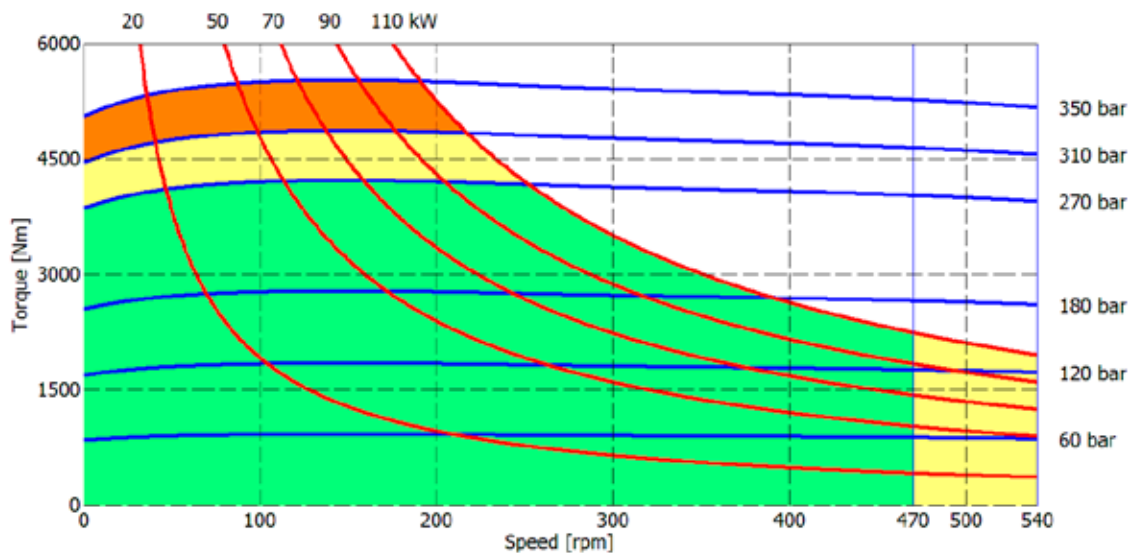

- Continuous operation
- Intermittent operation: permitted for a 15% of duty cycle, for 3 minutes maximum period.
- Peak operation: permitted for very short periods (3-5 seconds every 10-15 minutes).

The above diagrams are referring to the hydraulic motor working with a fluid in ideal conditions (viscosity at 40 cSt). In case the working temperature increases and viscosity reach values under the recommended values (see hydraulic fluid recommendations) flushing must be optimized or ISO oil grade must be changed. The working temperature must not overcome 70 °C.

The data specified into the catalogue are for product description purpose only and must not be interpreted as warranted characteristics in legal sense. ItalgrouP S.r.l. reserves the right to implement modifications without notice. All partial or total reproduction and copy without written authorization of ItalgrouP S.r.l. is strictly forbidden.

CREEP SPEED - VOLUMETRIC EFFICIENCY

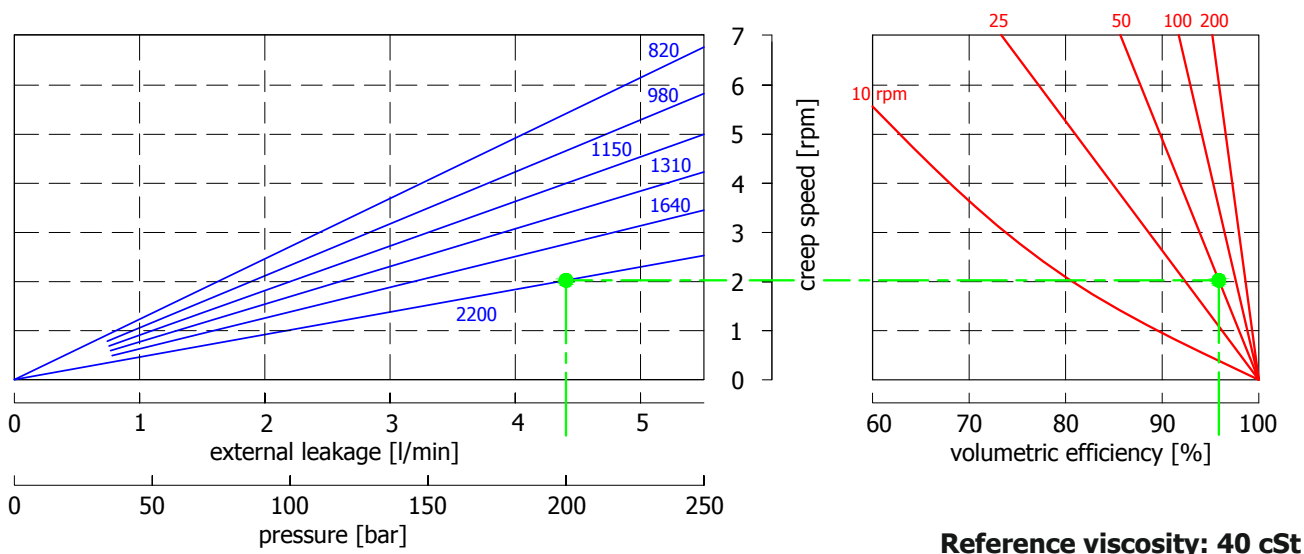

Example:

We suppose (2200 cc): $p=200$ [bar], we obtain: external leakage 4,3 [l/min], shaft creep speed 2 [rpm].
If we suppose (2200 cc): $p=200$ [bar] and $n=50$ [rpm] we obtain a volumetric efficiency of 96%;

BEARING LIFE

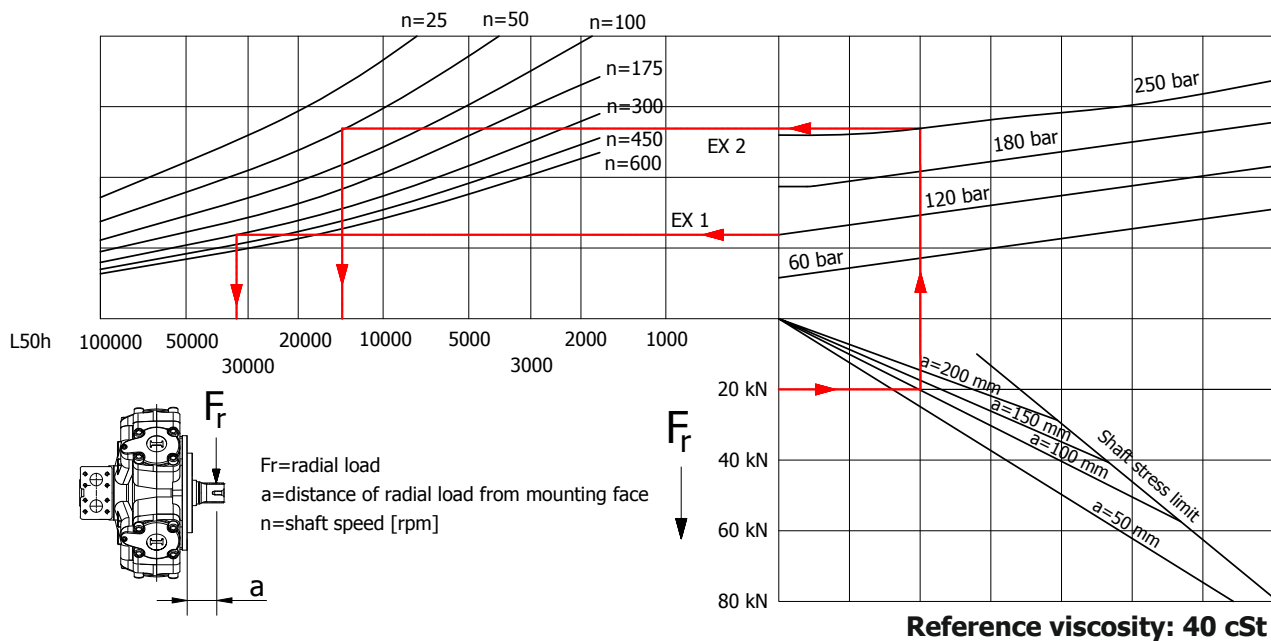

Example:

We suppose (EX1): $p=120$ [bar], $n=300$ [rpm]; we obtain an average lifetime of 34000 [h].
If we suppose (EX2): $F_r=20$ [kN], $a=100$ [mm], $n=50$ [rpm] and $p=250$ [bar] we obtain an average lifetime of 12000 [h].

The data specified into the catalogue are for product description purpose only and must not be interpreted as warranted characteristics in legal sense. ItalgrouP S.r.l. reserves the right to implement modifications without notice. All partial or total reproduction and copy without written authorization of ItalgrouP S.r.l. is strictly forbidden.

ITALGROUP SRL
IAC SERIES - IAC H6
GENERAL CATALOGUE

INDEX - IAC H6

TECHNICAL DATA	Pag	86
IAC 3000 H6 - INSTALLATION DRAWING	"	87
IAC 3000/C H6 - INSTALLATION DRAWING	"	88
IAC 3000/MRH H6 - INSTALLATION DRAWING	"	89
IAC H6 - NIP OPTION	"	90
IAC H6 - CETOP 3 FITTING	"	91
IAC H6 - ORDERING CODE	"	92
IAC 3000 H6 - PERFORMANCE DIAGRAMS	"	94 - 95

IAC 3000 H6

Displacement (*)	[cc]	3085	2950	2790	2620	2460	2290	2130	1970	1800	1640
Th. specific torque	[Nm/bar]	49,1	47	44,4	41,7	39,2	36,5	33,9	31,4	28,7	26,1
Continuous speed	[rpm]	235	240	245	250	250	265	285	305	340	370
Peak speed	[rpm]	280	280	300	300	300	320	340	350	400	420
Minimum speed	[rpm]	1	1	1	1	1	1	1	1	1	1
Mechanical efficiency	[%]	95	94,5	94,2	94	93,7	93,5	92,8	92,3	92	91
Starting efficiency	[%]	86	85,4	84,4	83,6	82,4	82	80,2	78	76	73
Continuous power (***)	[kW]	180	180	180	168	158	153	143	132	122	115
Cont. power with flushing	[kW]	270	270	270	253	238	228	212	196	185	175
Continuous pressure	[bar]	270	270	270	270	270	270	270	270	270	270
Intermittent pressure	[bar]	310	310	310	310	310	310	310	310	310	310
Peak pressure	[bar]	350	350	350	350	350	350	350	350	350	350
Flushing flow	[l/min]	12	12	12	12	12	12	12	12	12	12
Dry weight	[kg]	308	308	308	308	308	308	308	308	308	308

Displacement (*)	[cc]	1470	1310	1150	980	820	670	490	330	160	82	0
Th. specific torque	[Nm/bar]	23,4	20,9	18,3	15,6	13,1	10,7	7,8	5,2	2,5	1,3	0
Continuous speed	[rpm]	400	425	455	490	520	600	600	600	600	1000	1000
Peak speed	[rpm]	450	475	500	540	580	700	700	800	800	1200	1500
Minimum speed	[rpm]	1	1	1	1	2	2	2	3	5	-	-
Mechanical efficiency	[%]	90,5	88	86,2	82,3	81,7	78	76	73,2	25	0	0
Starting efficiency	[%]	70	66,4	62	55,4	46,3	33	0	0	0	0	0
Continuous power (***)	[kW]	106	100	100	100	90	80	70	40	8	0	0
Cont. power with flushing	[kW]	160	150	150	150	135	96	90	60	11	0	0
Continuous pressure	[bar]	270	250	250	250	250	250	250	250	250	17(**)	17(**)
Intermittent pressure	[bar]	310	310	310	310	310	310	310	310	310	17(**)	17(**)
Peak pressure	[bar]	350	350	350	350	350	350	350	350	350	17(**)	17(**)
Flushing flow	[l/min]	12	12	12	12	12	12	12	12	12	15	15
Dry weight	[kg]	308	308	308	308	308	308	308	308	308	308	308

(*) Different displacements can be available on request. Please contact Italgroupp S.r.l. for more information.

(**) Pressure limits at 1000 rpm. For lower speeds the values can be increased. Contact Italgroupp for more information.

(***) The continuous power and the continuous power with flushing are the output maximum power. To estimate the input power divide the output power by the mechanical efficiency. For example: if required output power is 150 kW and starting efficiency is 86%, estimated required power is $150/0.86 = 174,4$ kW.

Hydrostatic pressure test: 420 bar.

Temperature range: -30 / 70 °C.

IAC 3000 H6 - INSTALLATION DRAWING

XY DISPLACEMENT CHANGE CONFIGURATION

X - minimum displacement
Y - maximum displacement

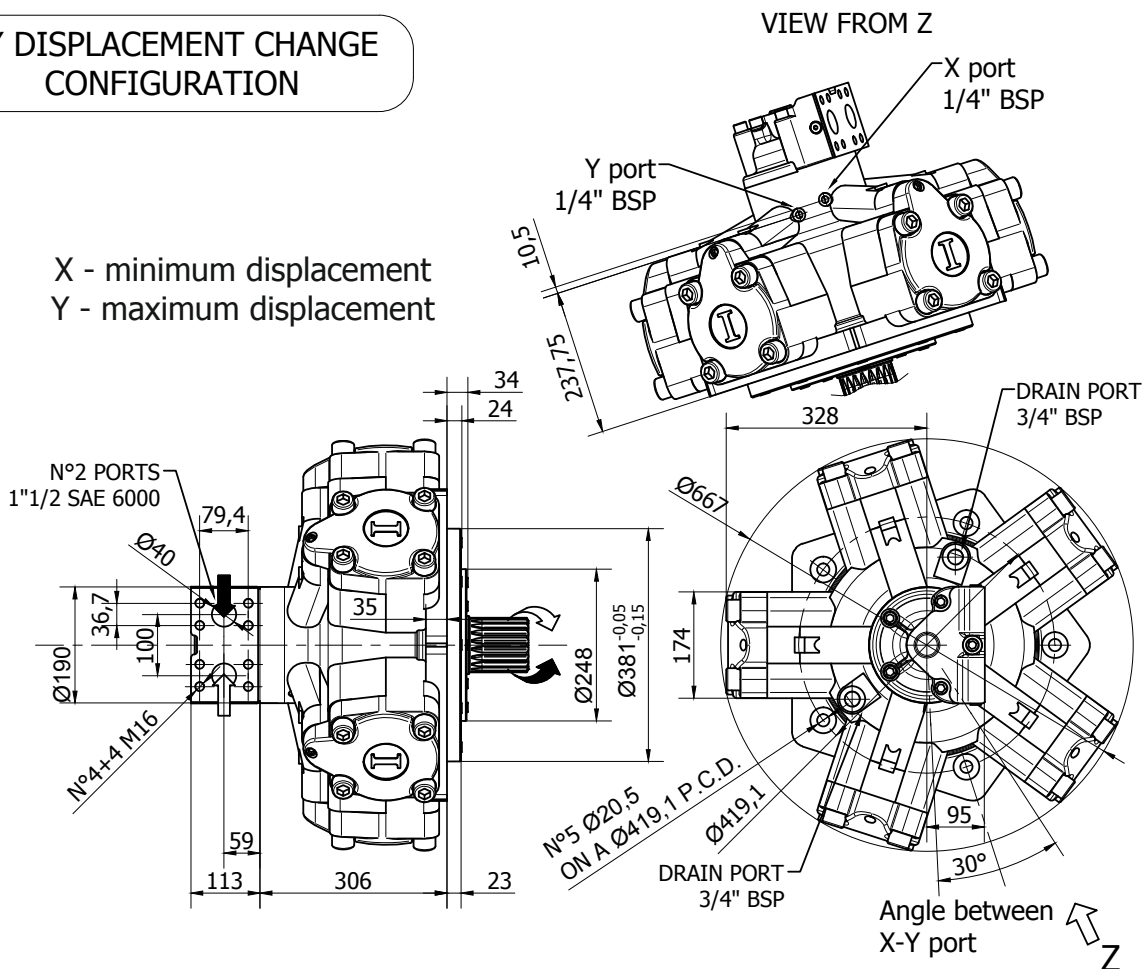

SHAFT TYPE: A0

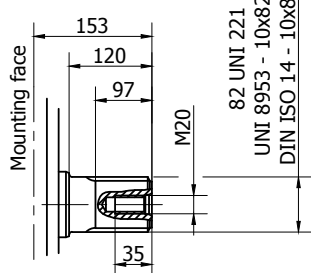

SHAFT TYPE: A1

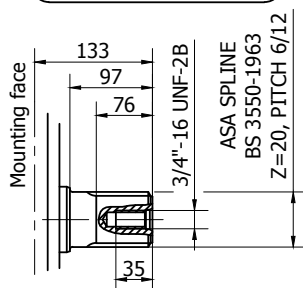

SHAFT TYPE: A2

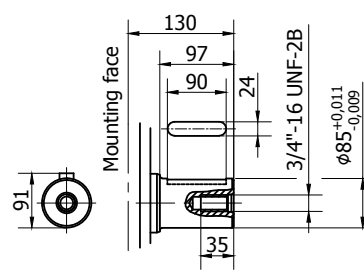

SHAFT TYPE: A11

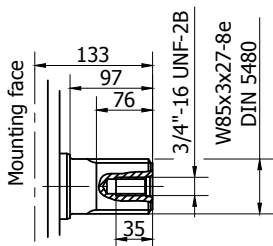

SHAFT TYPE: A12

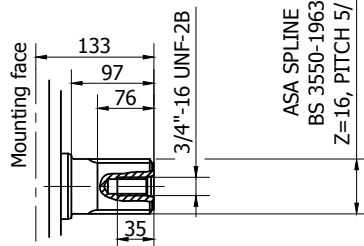

The data specified into the catalogue are for product description purpose only and must not be interpreted as warranted characteristics in legal sense. ItalgrouP S.r.l. reserves the right to implement modifications without notice. All partial or total reproduction and copy without written authorization of ItalgrouP S.r.l. is strictly forbidden.

XY DISPLACEMENT CHANGE CONFIGURATION

X - minimum displacement
 Y - maximum displacement

VIEW FROM Z

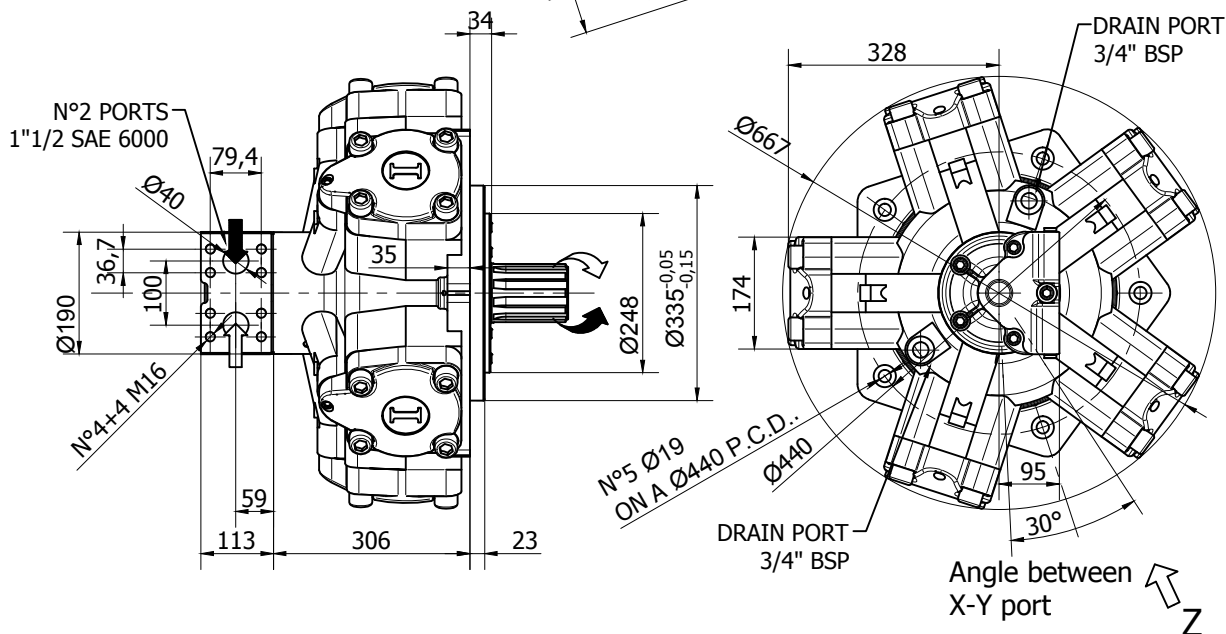
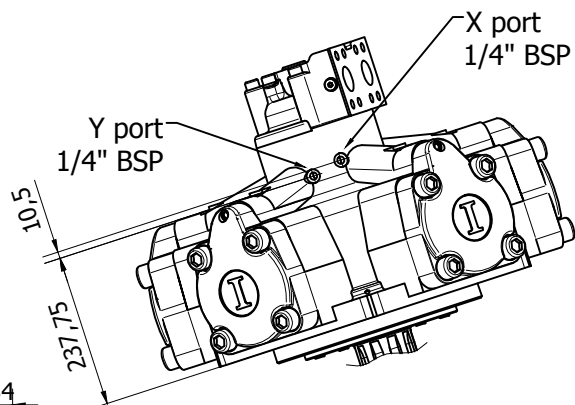

SHAFT TYPE: A0

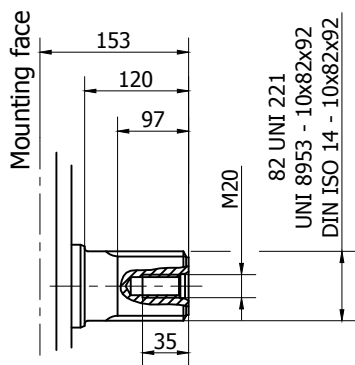

The data specified into the catalogue are for product description purpose only and must not be interpreted as warranted characteristics in legal sense. Italgrou S.r.l. reserves the right to implement modifications without notice. All partial or total reproduction and copy without written authorization of Italgrou S.r.l. is strictly forbidden.

IAC 3000/MRH H6 - INSTALLATION DRAWING



HYDRAULIC MOTORS
ITALY

XY DISPLACEMENT CHANGE CONFIGURATION

X - minimum displacement
Y - maximum displacement

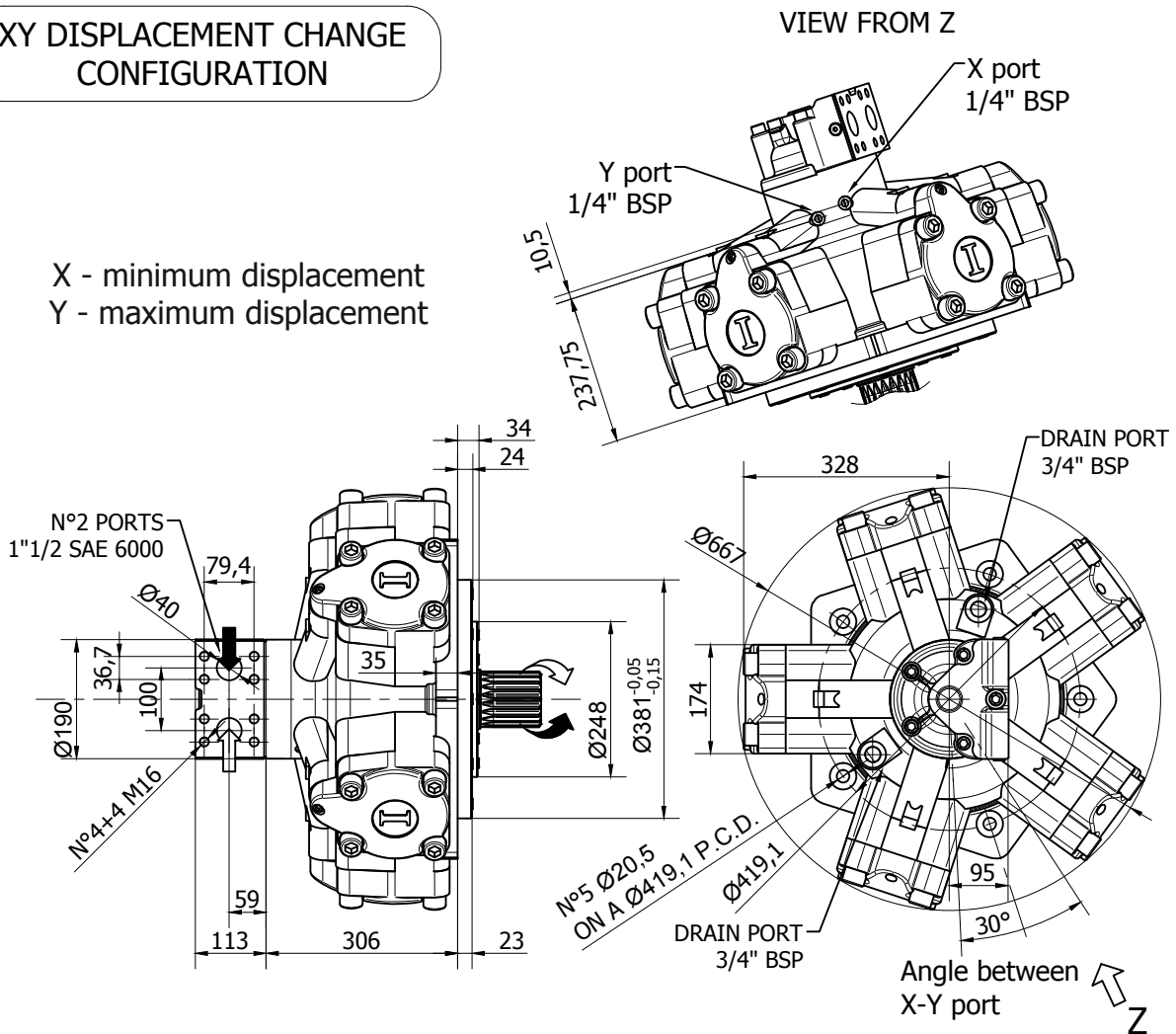

SHAFT TYPE: A1

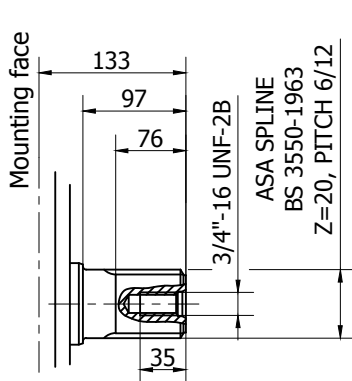

SHAFT TYPE: A13

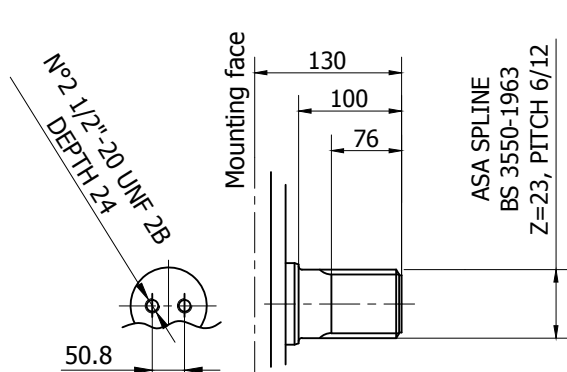

The data specified into the catalogue are for product description purpose only and must not be interpreted as warranted characteristics in legal sense. ItalgrouP S.r.l. reserves the right to implement modifications without notice. All partial or total reproduction and copy without written authorization of ItalgrouP S.r.l. is strictly forbidden.

**XY DISPLACEMENT CHANGE
 CONFIGURATION**

VIEW FROM Z

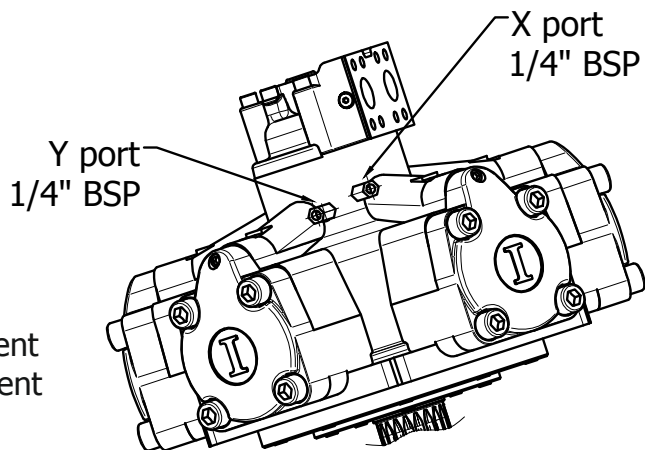

X - minimum displacement
 Y - maximum displacement

93 (standard version)
 133 (NIP version)

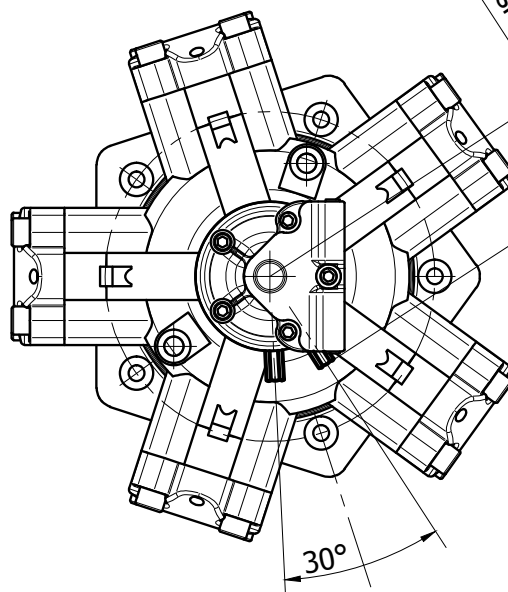
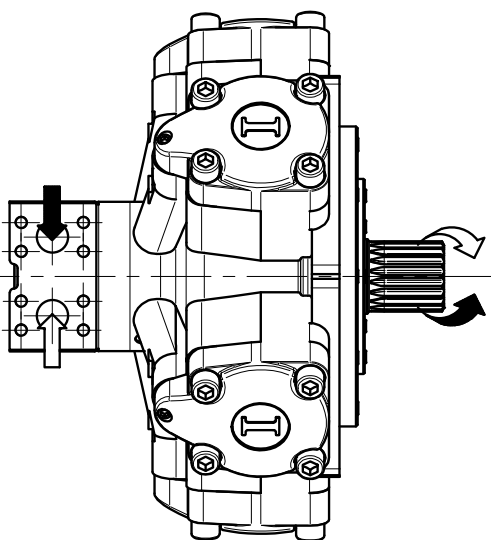

30°
 Angle between
 X-Y port

The data specified into the catalogue are for product description purpose only and must not be interpreted as warranted characteristics in legal sense. Italgrou S.r.l. reserves the right to implement modifications without notice. All partial or total reproduction and copy without written authorization of Italgrou S.r.l. is strictly forbidden.

IAC 3000 H6 - CETOP 3 FITTING

CETOP 3 DISPLACEMENT CHANGE CONFIGURATION

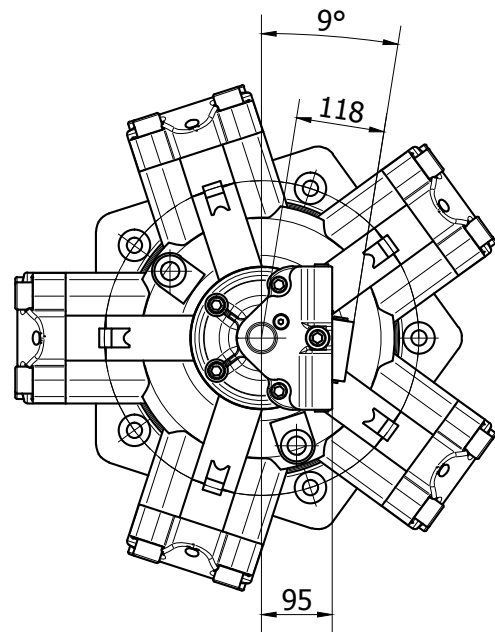
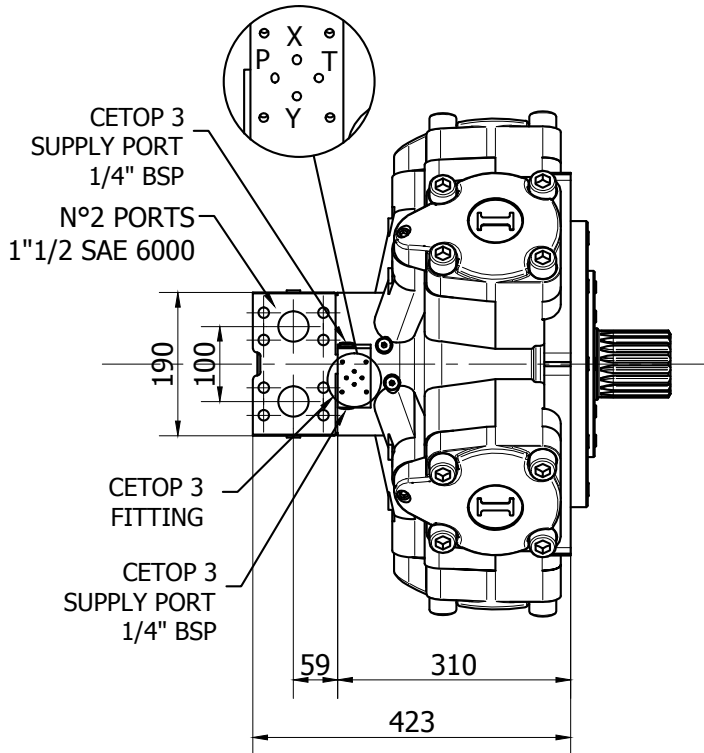

X - minimum displacement
Y - maximum displacement

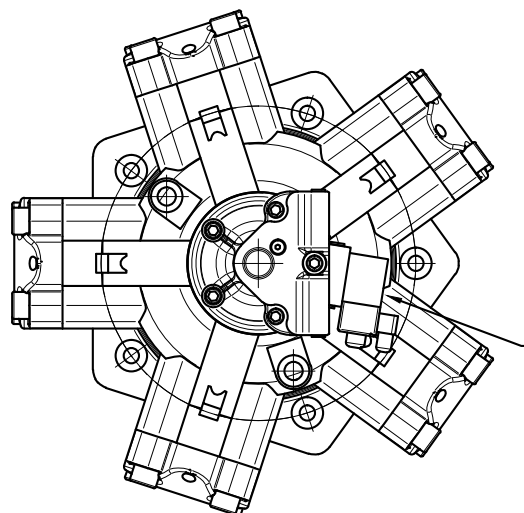

CETOP 3 DISPLACEMENT CHANGE
VALVE
C3 - 12 SV (12V DC)
C3 - 24 SV (24V DC)
C3 - HY SV (HYDRAULIC
OPERATED)

IAC 3000 H6 - ORDERING CODE

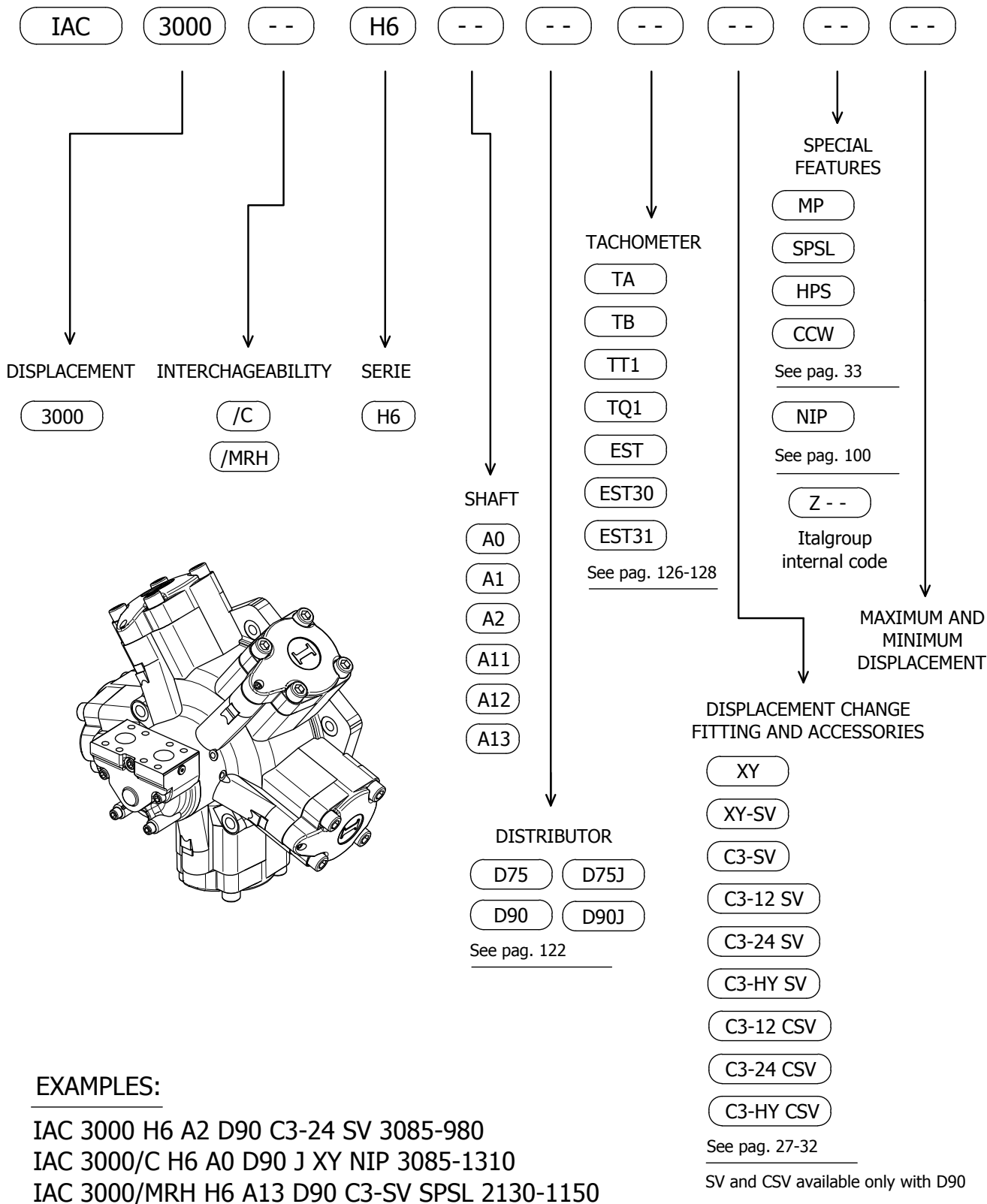

The data specified into the catalogue are for product description purpose only and must not be interpreted as warranted characteristics in legal sense. Italgroupp S.r.l. reserves the right to implement modifications without notice. All partial or total reproduction and copy without written authorization of Italgroupp S.r.l. is strictly forbidden.

3085 cc - WITHOUT FLUSHING

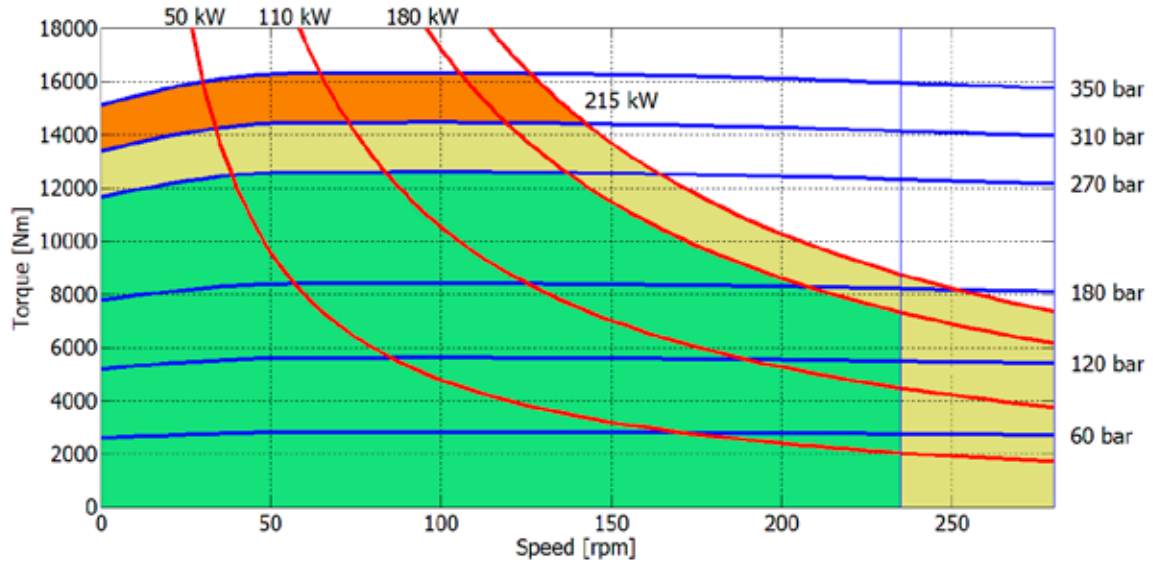

1470 cc - WITHOUT FLUSHING

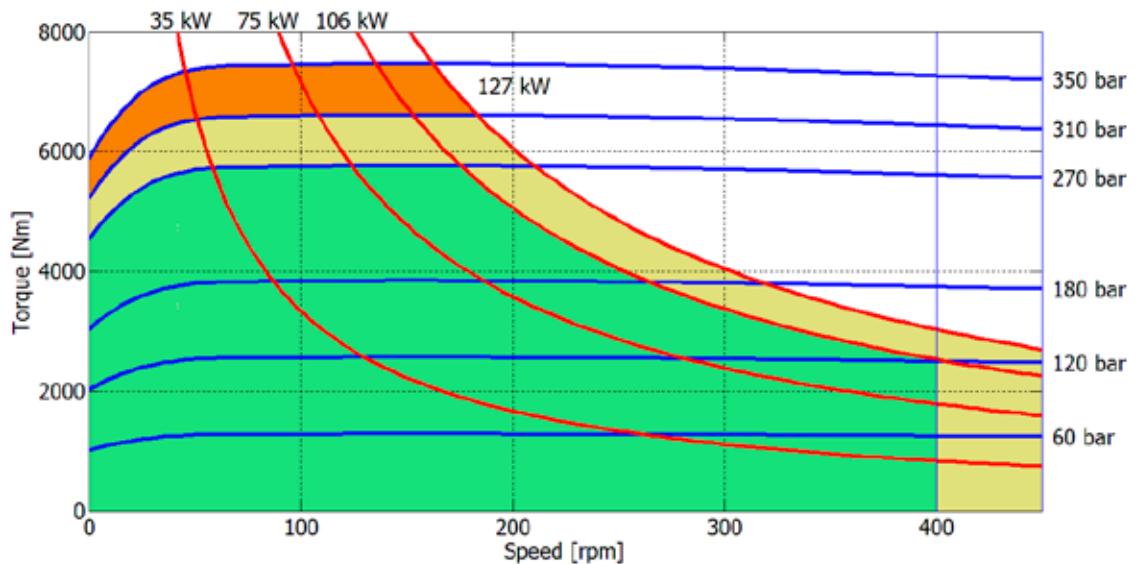

Continuous operation



Intermittent operation: permitted for a 15% of duty cycle, for 3 minutes maximum period.



Peak operation: permitted for very short periods (3-5 seconds every 10-15 minutes).

The above diagrams are referring to the hydraulic motor working with a fluid in ideal conditions (viscosity at 40 cSt). In case the working temperature increases and viscosity reach values under the recommended values (see hydraulic fluid recommendations) flushing must be performed or ISO oil grade must be changed. The working temperature must not overcome 70 °C.

The data specified into the catalogue are for product description purpose only and must not be interpreted as warranted characteristics in legal sense. Italgrou S.r.l. reserves the right to implement modifications without notice. All partial or total reproduction and copy without written authorization of Italgrou S.r.l. is strictly forbidden.

3085 cc - WITH FLUSHING

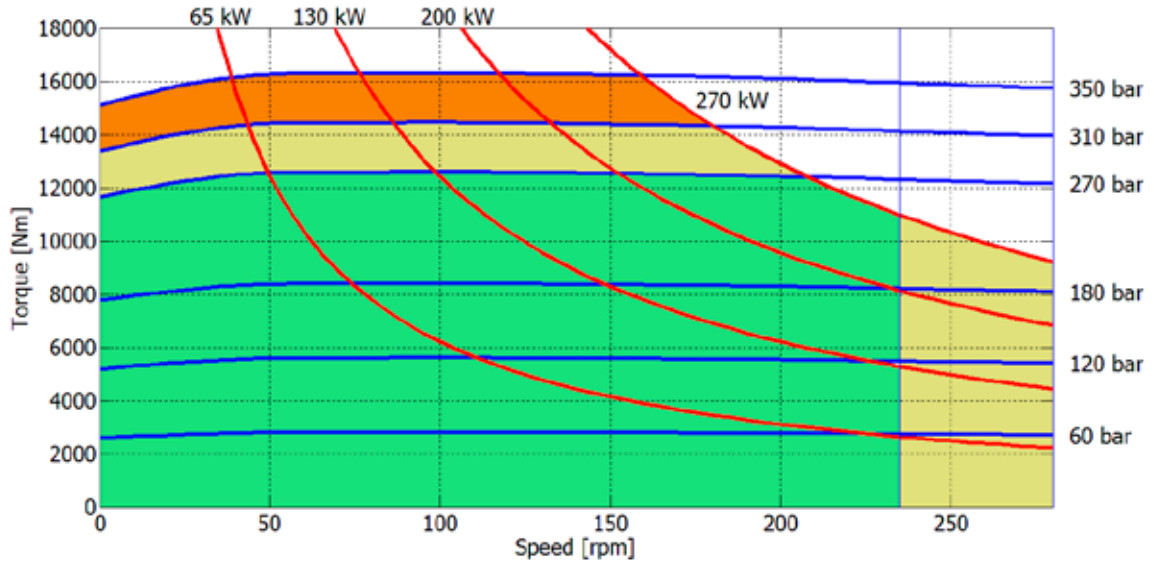

1470 cc - WITH FLUSHING

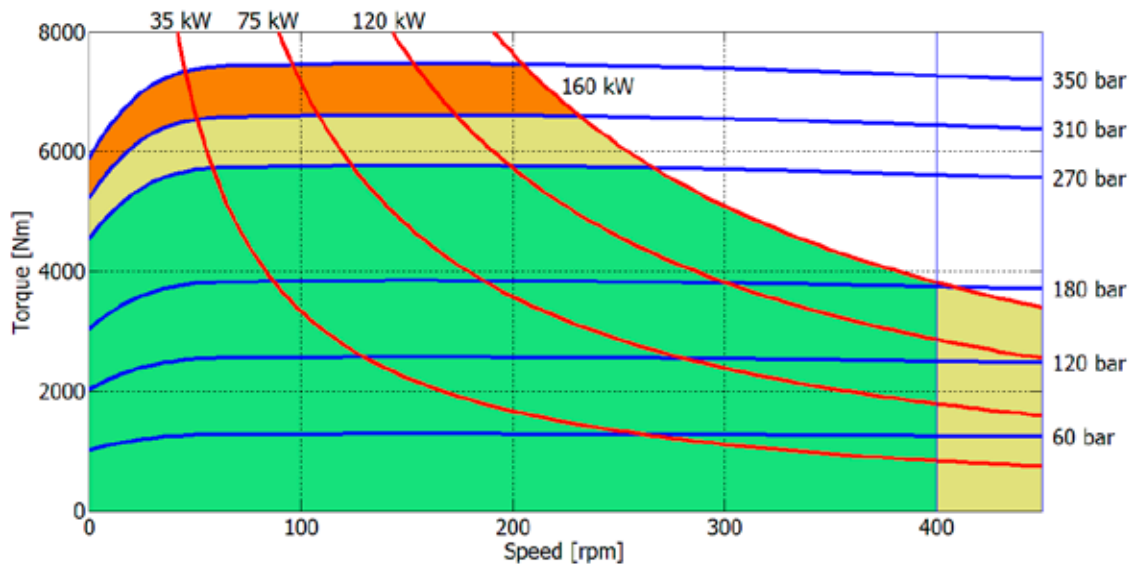

- Continuous operation
- Intermittent operation: permitted for a 15% of duty cycle, for 3 minutes maximum period.
- Peak operation: permitted for very short periods (3-5 seconds every 10-15 minutes).

The above diagrams are referring to the hydraulic motor working with a fluid in ideal conditions (viscosity at 40 cSt). In case the working temperature increases and viscosity reach values under the recommended values (see hydraulic fluid recommendations) flushing must be optimized or ISO oil grade must be changed. The working temperature must not overcome 70 °C.

The data specified into the catalogue are for product description purpose only and must not be interpreted as warranted characteristics in legal sense. ItalgrouP S.r.l. reserves the right to implement modifications without notice. All partial or total reproduction and copy without written authorization of ItalgrouP S.r.l. is strictly forbidden.

CREEP SPEED - VOLUMETRIC EFFICIENCY

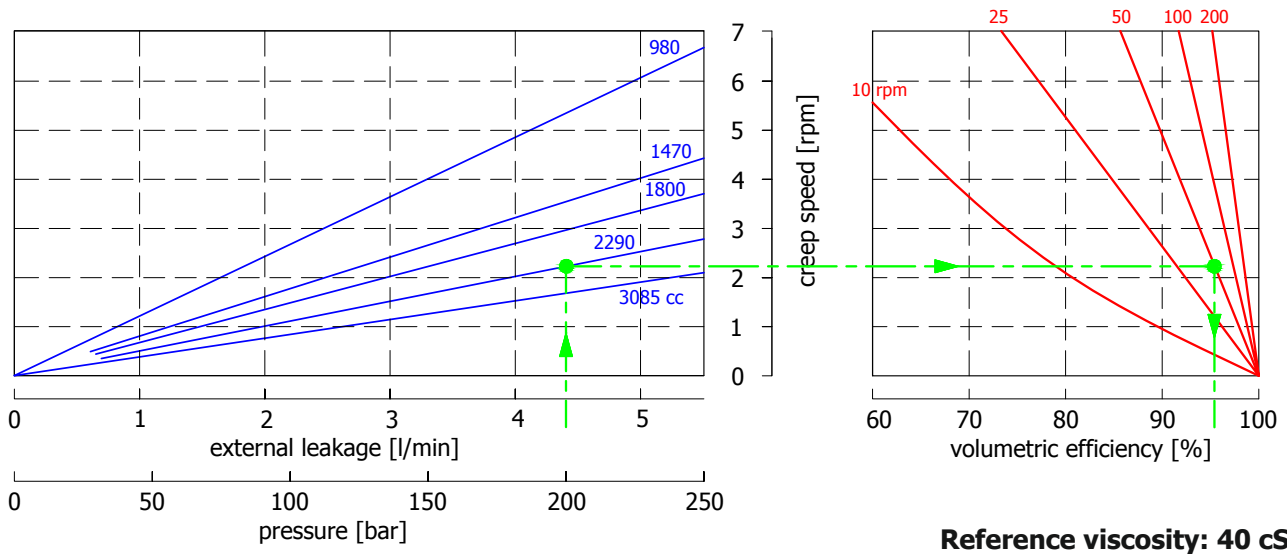

Example:

We suppose (2290 cc): $p=200$ [bar], we obtain: external leakage 4,3 [l/min], shaft creep speed 2,2 [rpm].
If we suppose (2290 cc): $p=200$ [bar] and $n=50$ [rpm] we obtain a volumetric efficiency of 96%;

BEARING LIFE

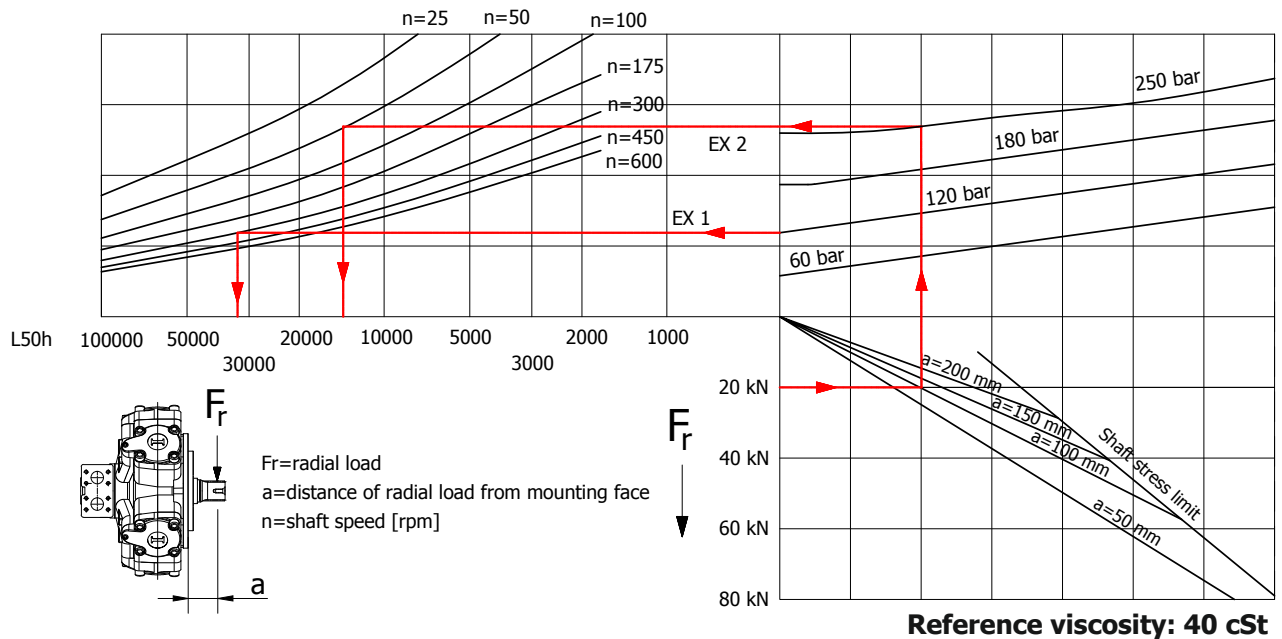

Example:

We suppose (EX1): $p=120$ [bar], $n=300$ [rpm]; we obtain an average lifetime of 34000 [h].

If we suppose (EX2): $F_r=20$ [kN], $a=100$ [mm], $n=50$ [rpm] and $p=250$ [bar] we obtain an average lifetime of 12000 [h].

The data specified into the catalogue are for product description purpose only and must not be interpreted as warranted characteristics in legal sense. Italgrou S.r.l. reserves the right to implement modifications without notice. All partial or total reproduction and copy without written authorization of Italgrou S.r.l. is strictly forbidden.

ITALGROUP SRL
IAC SERIES - IAC H7
GENERAL CATALOGUE

INDEX - IAC H7

<u>TECHNICAL DATA</u>	Pag	98 - 99
<u>IAC 4600-5400 H7 - INSTALLATION DRAWING</u>	“	100
<u>IAC 4600-5400/MRH H7 - INSTALLATION DRAWING</u>	“	101
<u>IAC H7 - NIP OPTION</u>	“	102
<u>IAC H7 - CETOP 3 FITTING</u>	“	103
<u>IAC H7 - ORDERING CODE</u>	“	104
<u>IAC 4600 H7 - PERFORMANCE DIAGRAMS</u>	“	106 - 107
<u>IAC 5400 H7 - PERFORMANCE DIAGRAMS</u>	“	108 - 109

IAC 4600 H7 - TECHNICAL DATA

IAC 4600 H7

Displacement (*)	[cc]	4617	4177	3650	3280	2950	2620	2290	1970
Th. specific torque	[Nm/bar]	73,5	66,5	58,1	52,2	47	41,7	36,5	31,4
Continuous speed	[rpm]	150	158	168	175	210	235	275	305
Peak speed	[rpm]	170	185	210	230	255	280	330	380
Minimum speed	[rpm]	1	1	1	1	1	1	1	1
Mechanical efficiency	[%]	95,3	95,1	94,5	94,4	93,3	92,4	91,5	90,1
Starting efficiency	[%]	85,1	84	83,3	82,5	81,2	80,1	78	75,2
Continuous power (***)	[kW]	195	190	175	155	145	135	120	110
Cont. power with flushing	[kW]	290	270	250	235	215	200	180	165
Continuous pressure	[bar]	270	270	270	270	270	270	270	250
Intermittent pressure	[bar]	310	310	310	310	310	310	310	310
Peak pressure	[bar]	350	350	350	350	350	350	350	350
Flushing flow	[l/min]	12	12	12	12	12	12	12	12
Dry weight	[kg]	405	405	405	405	405	405	405	405

Displacement (*)	[cc]	1640	1310	980	655	492	328	164	82	0
Th. specific torque	[Nm/bar]	26,1	20,9	15,6	10,4	7,8	5,2	2,6	0	0
Continuous speed	[rpm]	380	435	460	495	520	550	600	1000	1000
Peak speed	[rpm]	470	530	550	600	600	650	700	1200	1500
Minimum speed	[rpm]	1	1	1	2	2	3	6	-	-
Mechanical efficiency	[%]	86,5	83	78,4	76,2	66	46,4	25	0	0
Starting efficiency	[%]	72,4	67,2	58	41	23,7	0	0	0	0
Continuous power (***)	[kW]	110	95	75	50	45	25	10	0	0
Cont. power with flushing	[kW]	165	140	112	80	65	32	10	0	0
Continuous pressure	[bar]	250	250	250	250	250	250	250	17(**)	17(**)
Intermittent pressure	[bar]	310	310	310	310	310	310	310	17(**)	17(**)
Peak pressure	[bar]	350	350	350	350	350	350	350	17(**)	17(**)
Flushing flow	[l/min]	12	12	12	12	12	12	12	15	15
Dry weight	[kg]	405	405	405	405	405	405	405	405	405

(*) Different displacements can be available on request. Please contact ItalgrouP S.r.l. for more information.

(**) Pressure limits at 1000 rpm. For lower speeds the values can be increased. Contact ItalgrouP for more information.

(***) The continuous power and the continuous power with flushing are the output maximum power. To estimate the input power divide the output power by the mechanical efficiency. For example: if required output power is 160 kW and starting efficiency is 85,1%, estimated required power is $160/0.851 = 188$ kW.

Hydrostatic pressure test: 420 bar.

Temperature range: -30 / 70 °C.

IAC 5400 H7 - TECHNICAL DATA



IAC 5400 H7

Displacement (*)	[cc]	5326	5080	4915	4588	4097	3650	3280	2950	2620
Th. specific torque	[Nm/bar]	84,8	80,9	78,2	73	65,2	58,1	52,2	47	41,7
Continuous speed	[rpm]	130	135	140	150	160	170	190	215	230
Peak speed	[rpm]	145	150	155	165	185	210	235	260	290
Minimum speed	[rpm]	1	1	1	1	1	1	1	1	1
Mechanical efficiency	[%]	95,2	95	95	95	95	94,4	94,3	93,2	92
Starting efficiency	[%]	86	85,8	85,8	85,4	85,2	83	82,2	82	79,8
Continuous power (***)	[kW]	195	195	195	190	180	165	155	145	135
Cont. power with flushing	[kW]	265	260	260	255	245	230	230	215	200
Continuous pressure	[bar]	250	250	250	250	250	250	250	250	250
Intermittent pressure	[bar]	310	310	310	310	310	310	310	310	310
Peak pressure	[bar]	350	350	350	350	350	350	350	350	350
Flushing flow	[l/min]	12	12	12	12	12	12	12	12	12
Dry weight	[kg]	405	405	405	405	405	405	405	405	405

Displacement (*)	[cc]	2295	1640	1311	980	655	492	328	164	0
Th. specific torque	[Nm/bar]	36,5	26,1	20,9	15,6	10,4	7,8	5,2	1,6	0
Continuous speed	[rpm]	280	375	445	470	500	520	550	1000	1000
Peak speed	[rpm]	335	450	530	550	600	600	650	1200	1500
Minimum speed	[rpm]	1	1	1	1	2	2	3	-	-
Mechanical efficiency	[%]	91,5	86	82,3	78,3	76,2	66,2	46,5	0	0
Starting efficiency	[%]	77,7	72,1	67	58	41	24	0	0	0
Continuous power (***)	[kW]	125	125	95	95	60	40	28	0	0
Cont. power with flushing	[kW]	185	185	135	135	80	60	32	0	0
Continuous pressure	[bar]	250	250	250	250	250	250	250	17(**)	17(**)
Intermittent pressure	[bar]	310	310	310	310	310	310	310	17(**)	17(**)
Peak pressure	[bar]	350	350	350	350	350	350	350	17(**)	17(**)
Flushing flow	[l/min]	12	12	12	12	12	12	12	15	15
Dry weight	[kg]	405	405	405	405	405	405	405	405	405

(*) Different displacements can be available on request. Please contact ItalgrouP S.r.l. for more information.

(**) Pressure limits at 1000 rpm. For lower speeds the values can be increased. Contact ItalgrouP for more information.

(***) The continuous power and the continuous power with flushing are the output maximum power. To estimate the input power divide the output power by the mechanical efficiency. For example: if required output power is 160 kW and starting efficiency is 86%, estimated required power is $160/0.86 = 186$ kW.

Hydrostatic pressure test: 420 bar.

Temperature range: -30 / 70 °C.

The data specified into the catalogue are for product description purpose only and must not be interpreted as warranted characteristics in legal sense. ItalgrouP S.r.l. reserves the right to implement modifications without notice. All partial or total reproduction and copy without written authorization of ItalgrouP S.r.l. is strictly forbidden.

XY DISPLACEMENT CHANGE CONFIGURATION

X - minimum displacement
Y - maximum displacement

VIEW FROM Z
(See page 76)

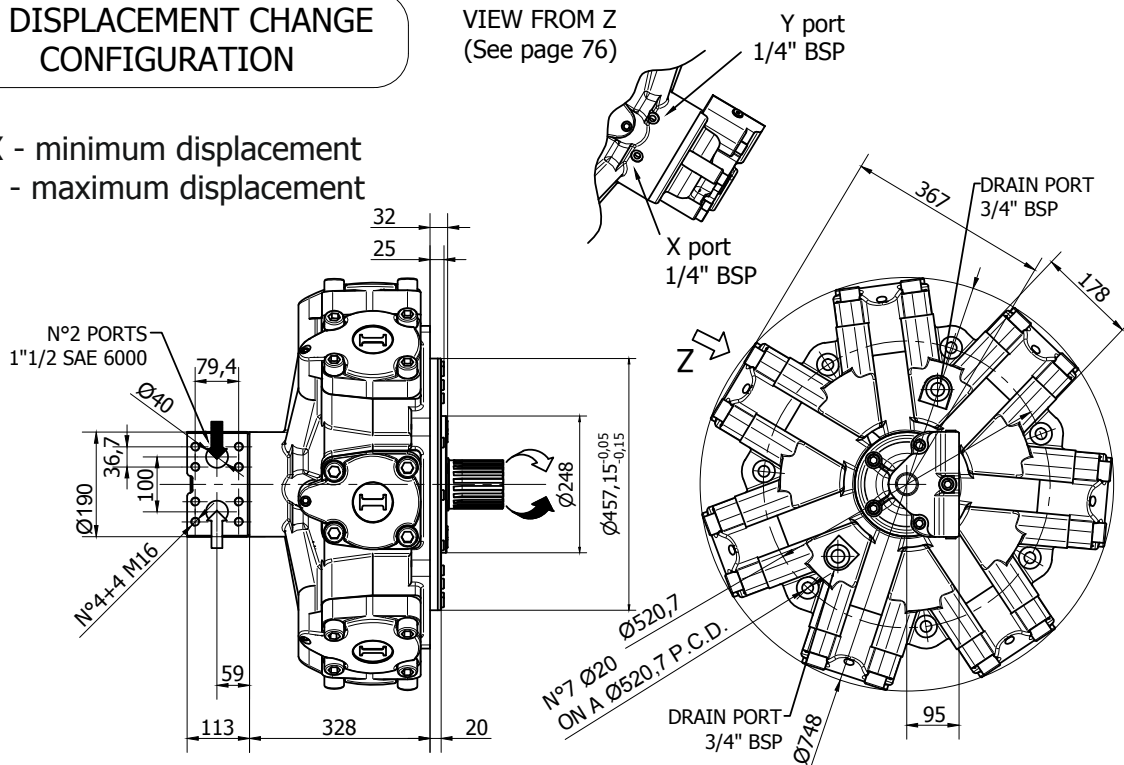

SHAFT TYPE: A1

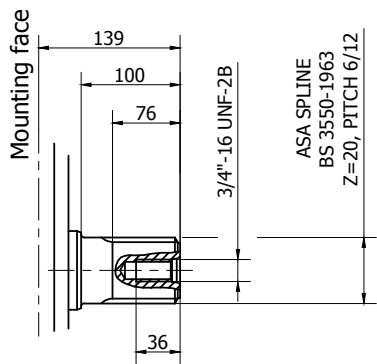

SHAFT TYPE: A11

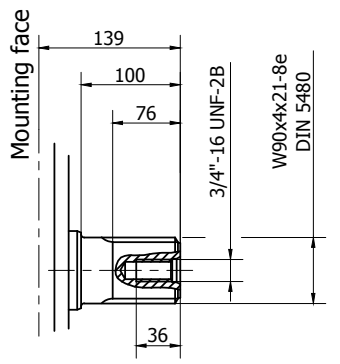

SHAFT TYPE: A12

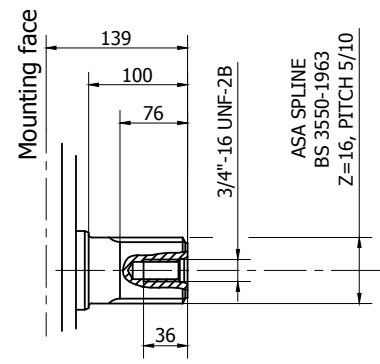

SHAFT TYPE: A31

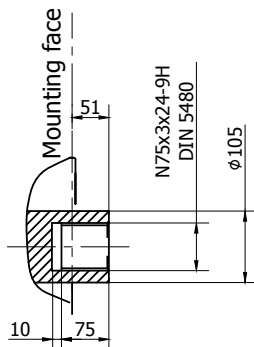

SHAFT TYPE: A3

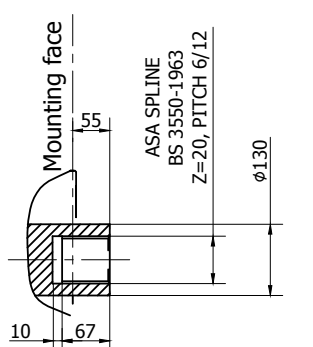

SHAFT TYPE: A2

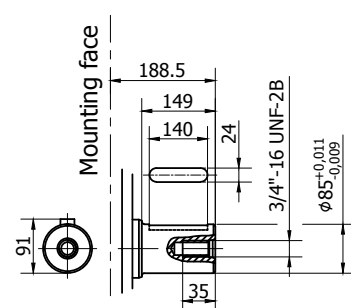

The data specified into the catalogue are for product description purpose only and must not be interpreted as warranted characteristics in legal sense. Italgrou S.r.l. reserves the right to implement modifications without notice. All partial or total reproduction and copy without written authorization of Italgrou S.r.l. is strictly forbidden.

XY DISPLACEMENT CHANGE CONFIGURATION

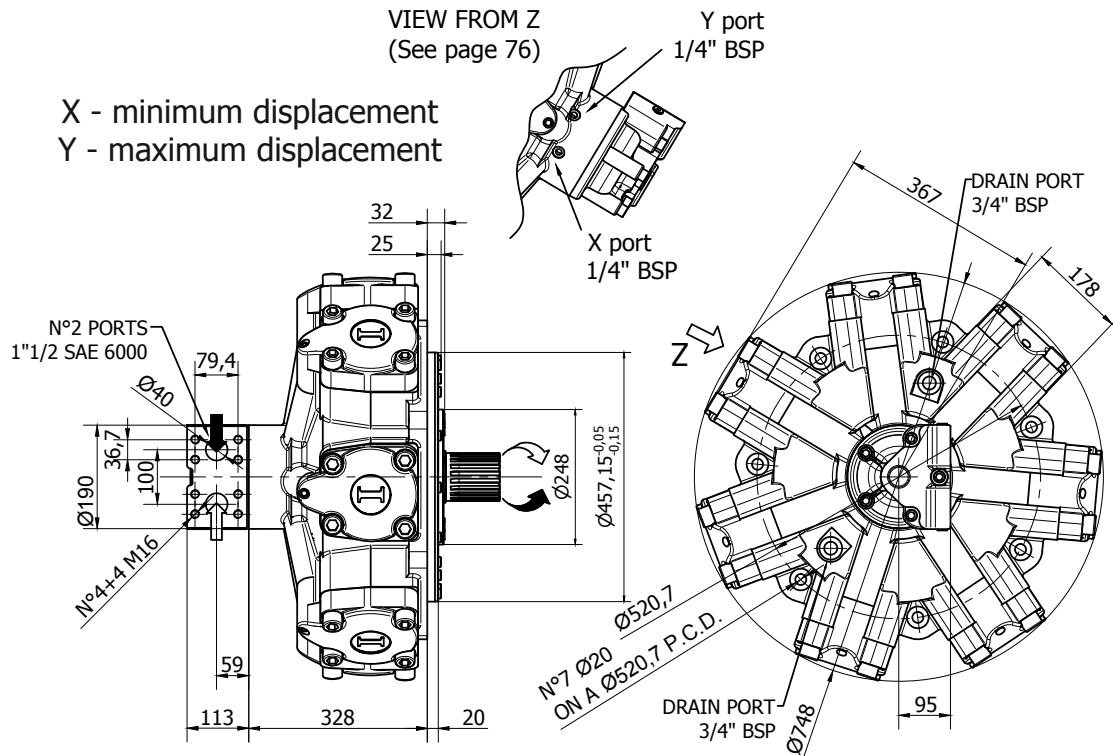

SHAFT TYPE: A1

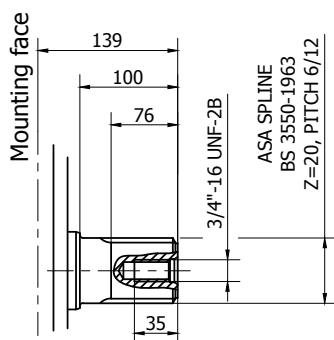

SHAFT TYPE: A13

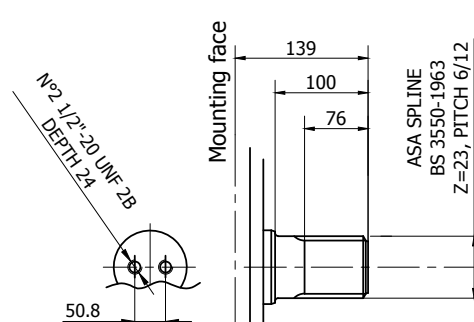

The data specified into the catalogue are for product description purpose only and must not be interpreted as warranted characteristics in legal sense. ItalgrouP S.r.l. reserves the right to implement modifications without notice. All partial or total reproduction and copy without written authorization of ItalgrouP S.r.l. is strictly forbidden.

XY DISPLACEMENT CHANGE CONFIGURATION

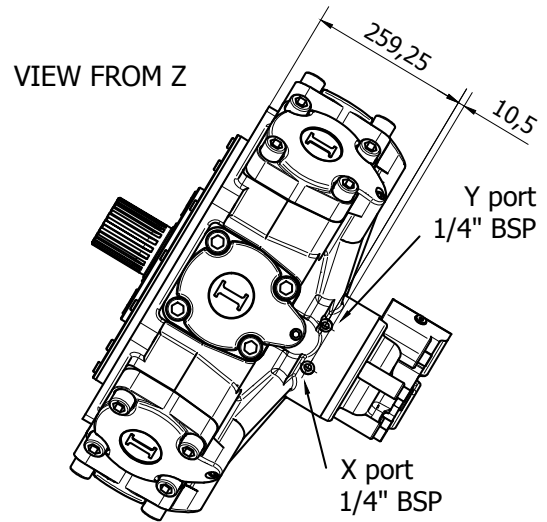
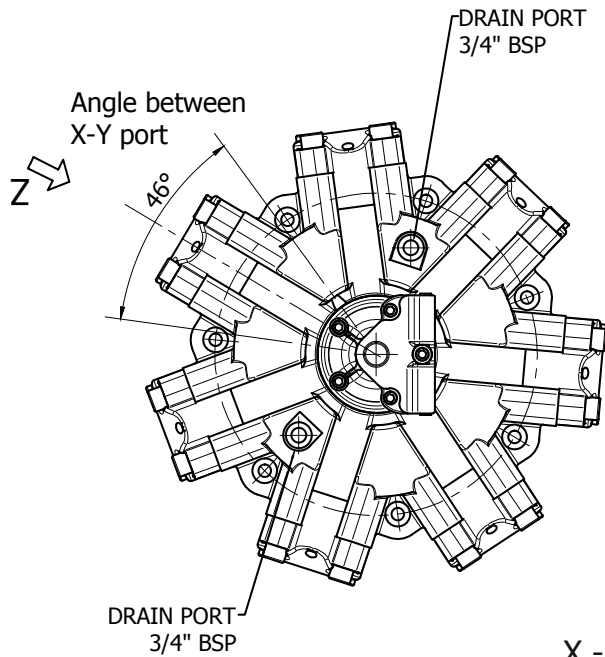

X - minimum displacement
 Y - maximum displacement

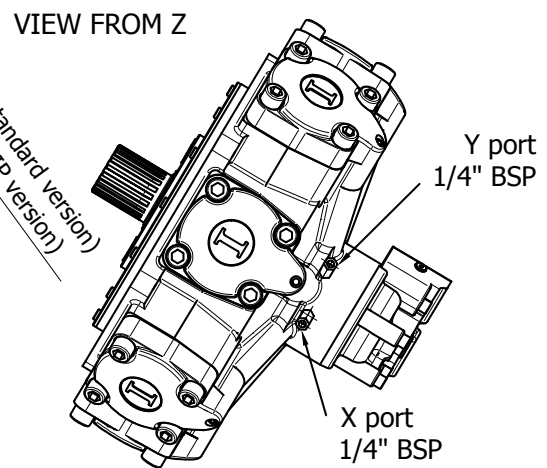
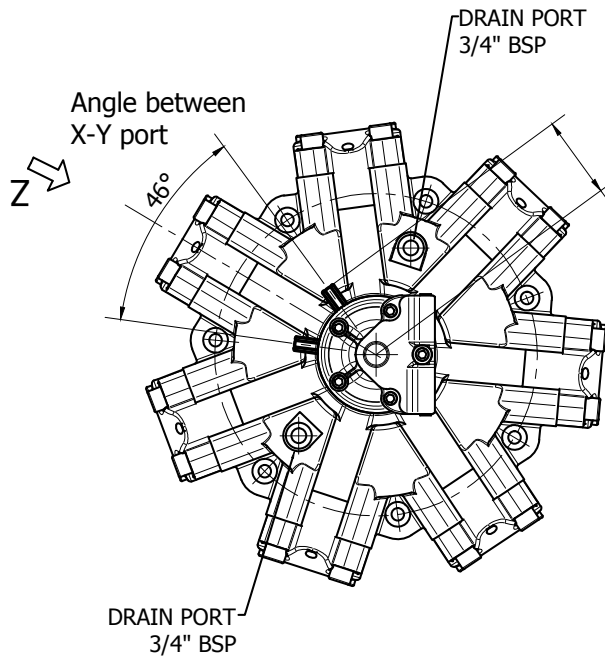

The data specified into the catalogue are for product description purpose only and must not be interpreted as warranted characteristics in legal sense. Italgrou S.r.l. reserves the right to implement modifications without notice. All partial or total reproduction and copy without written authorization of Italgrou S.r.l. is strictly forbidden.

CETOP 3 DISPLACEMENT
CHANGE CONFIGURATION

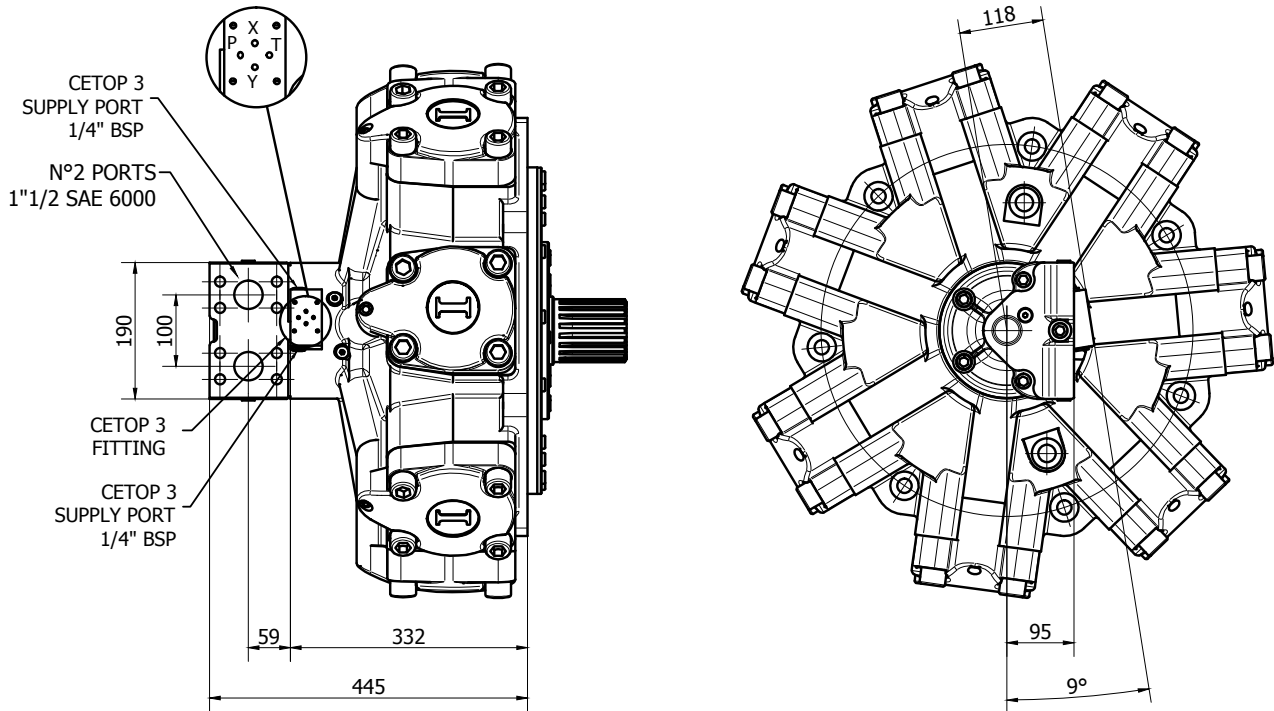

X - minimum displacement
Y - maximum displacement

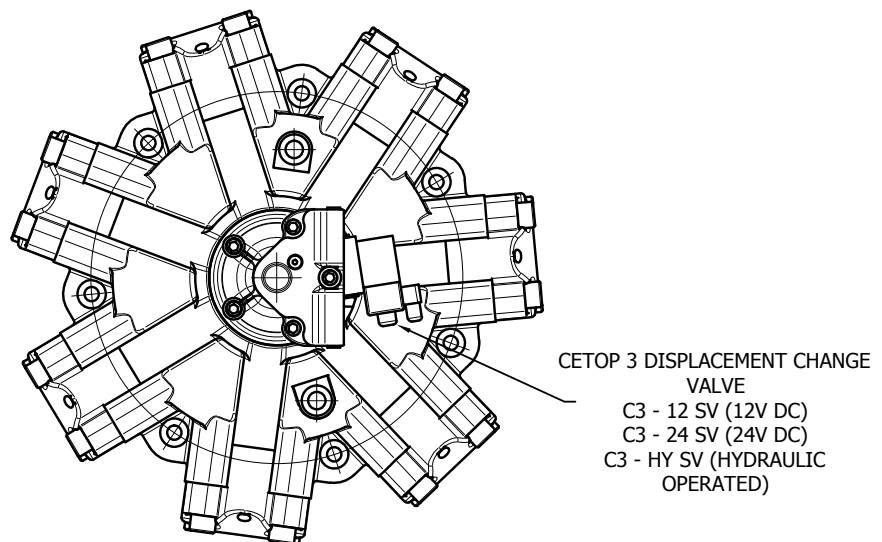

The data specified into the catalogue are for product description purpose only and must not be interpreted as warranted characteristics in legal sense. Italgrou S.r.l. reserves the right to implement modifications without notice. All partial or total reproduction and copy without written authorization of Italgrou S.r.l. is strictly forbidden.

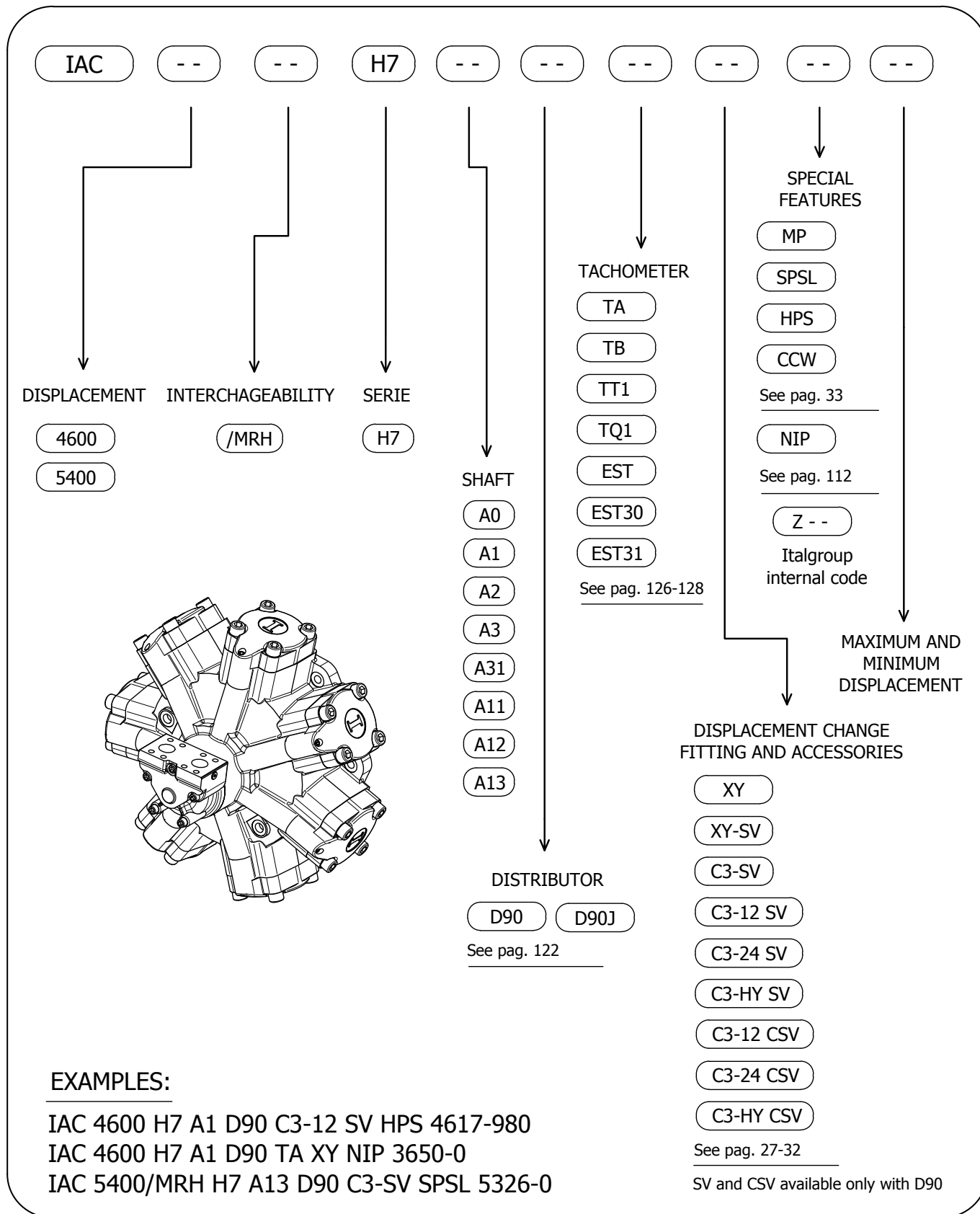

4617 cc - WITHOUT FLUSHING

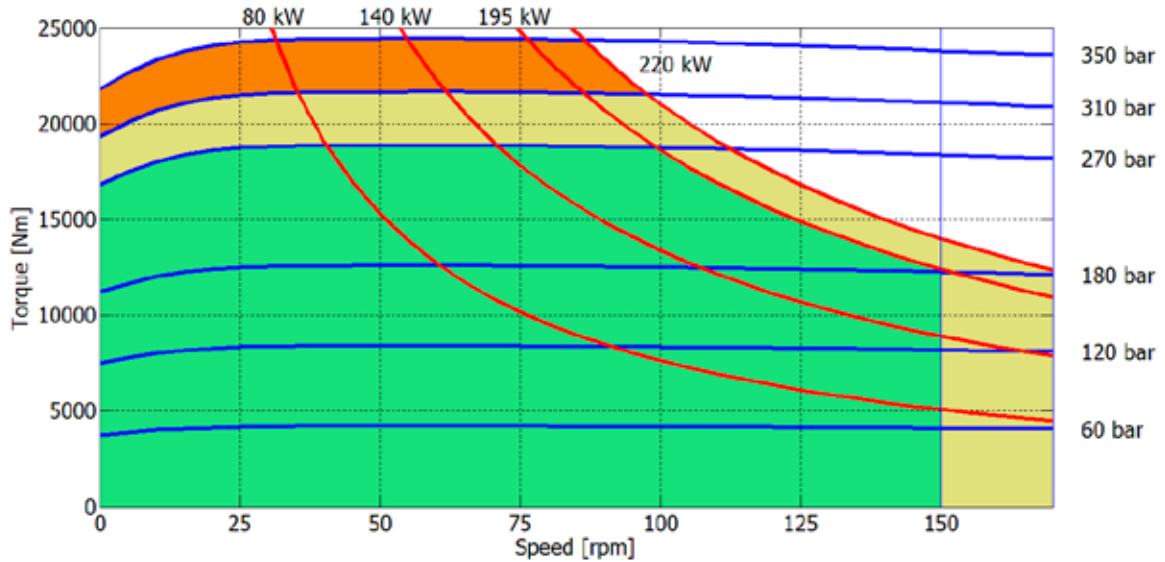

2290 cc - WITHOUT FLUSHING

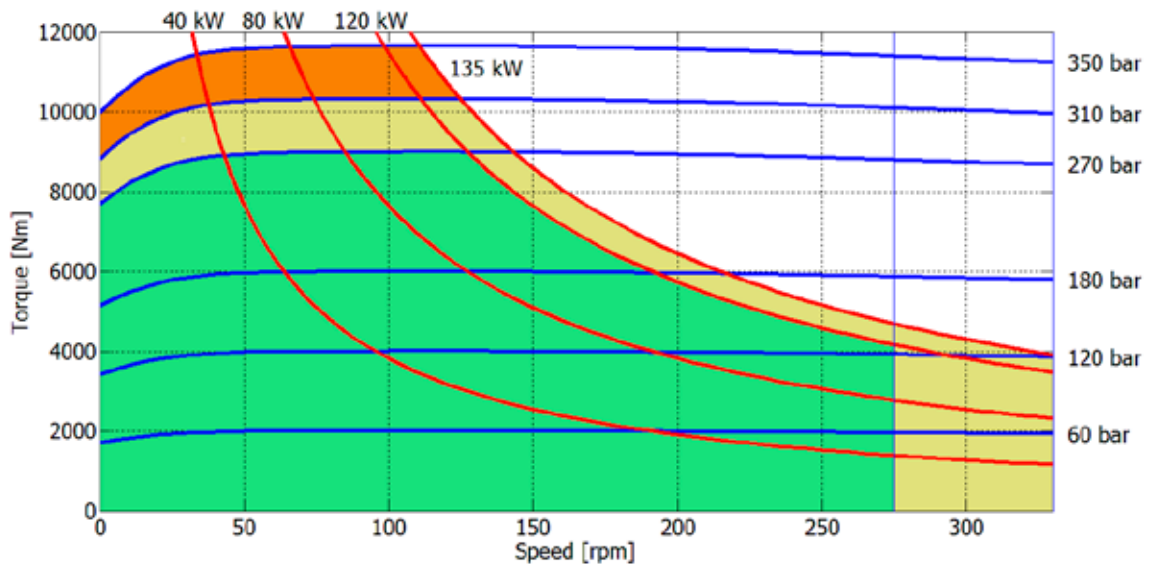

- Continuous operation
- Intermittent operation: permitted for a 15% of duty cycle, for 3 minutes maximum period.
- Peak operation: permitted for very short periods (3-5 seconds every 10-15 minutes).

The above diagrams are referring to the hydraulic motor working with a fluid in ideal conditions (viscosity at 40 cSt). In case the working temperature increases and viscosity reach values under the recommended values (see hydraulic fluid recommendations) flushing must be performed or ISO oil grade must be changed. The working temperature must not overcome 70 °C.

The data specified into the catalogue are for product description purpose only and must not be interpreted as warranted characteristics in legal sense. ItalgrouP S.r.l. reserves the right to implement modifications without notice. All partial or total reproduction and copy without written authorization of ItalgrouP S.r.l. is strictly forbidden.

4617 cc - WITH FLUSHING

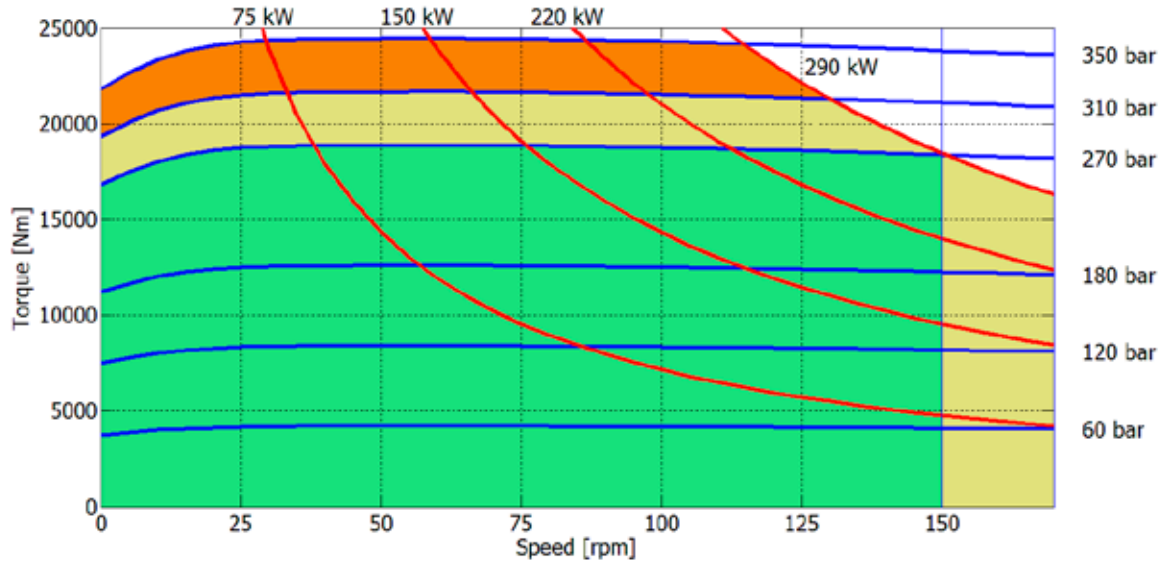

2290 cc - WITH FLUSHING

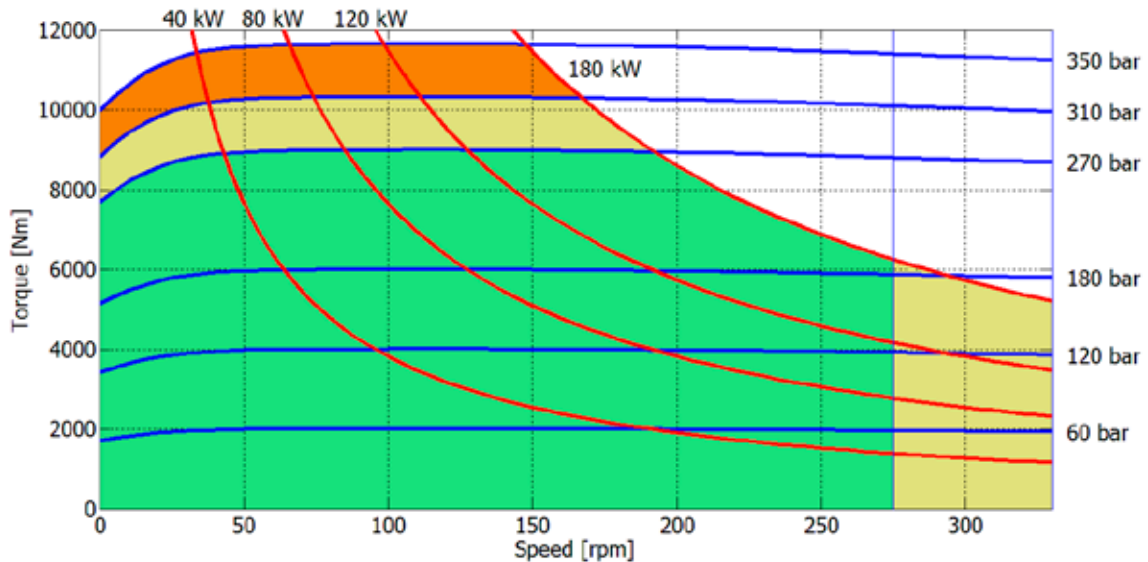

- Continuous operation
- Intermittent operation: permitted for a 15% of duty cycle, for 3 minutes maximum period.
- Peak operation: permitted for very short periods (3-5 seconds every 10-15 minutes).

The above diagrams are referring to the hydraulic motor working with a fluid in ideal conditions (viscosity at 40 cSt). In case the working temperature increases and viscosity reach values under the recommended values (see hydraulic fluid recommendations) flushing must be optimized or ISO oil grade must be changed. The working temperature must not overcome 70 °C.

The data specified into the catalogue are for product description purpose only and must not be interpreted as warranted characteristics in legal sense. Italgrou S.r.l. reserves the right to implement modifications without notice. All partial or total reproduction and copy without written authorization of Italgrou S.r.l. is strictly forbidden.

CREEP SPEED - VOLUMETRIC EFFICIENCY

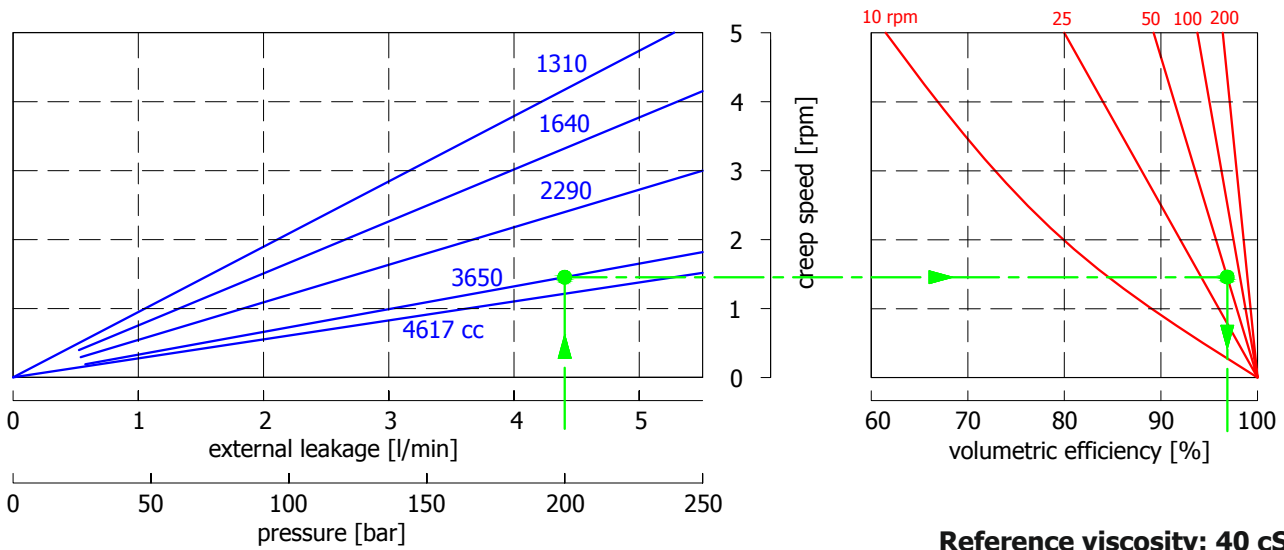

Example:

We suppose (3650 cc): $p=200$ [bar], we obtain: external leakage 4,3 [l/min], shaft creep speed 1,5 [rpm].
 If we suppose (3650 cc): $p=200$ [bar] and $n=50$ [rpm] we obtain a volumetric efficiency of 97,5%;

BEARING LIFE

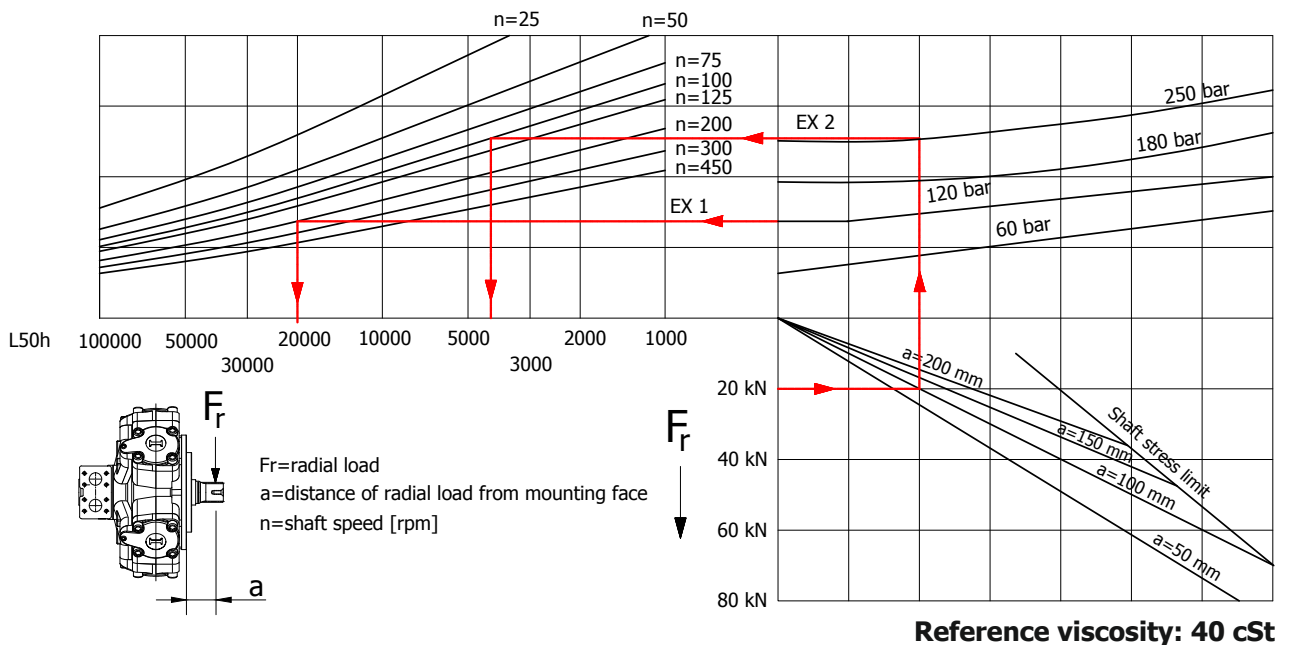

Example:

We suppose (EX1): $p=120$ [bar], $n=200$ [rpm]; we obtain an average lifetime of 25000 [h].
 If we suppose (EX2): $F_r=20$ [kN], $a=100$ [mm], $n=50$ [rpm] and $p=250$ [bar] we obtain an average lifetime of 6500 [h].

The data specified into the catalogue are for product description purpose only and must not be interpreted as warranted characteristics in legal sense. ItalgrouP S.r.l. reserves the right to implement modifications without notice. All partial or total reproduction and copy without written authorization of ItalgrouP S.r.l. is strictly forbidden.

5326 cc - WITHOUT FLUSHING

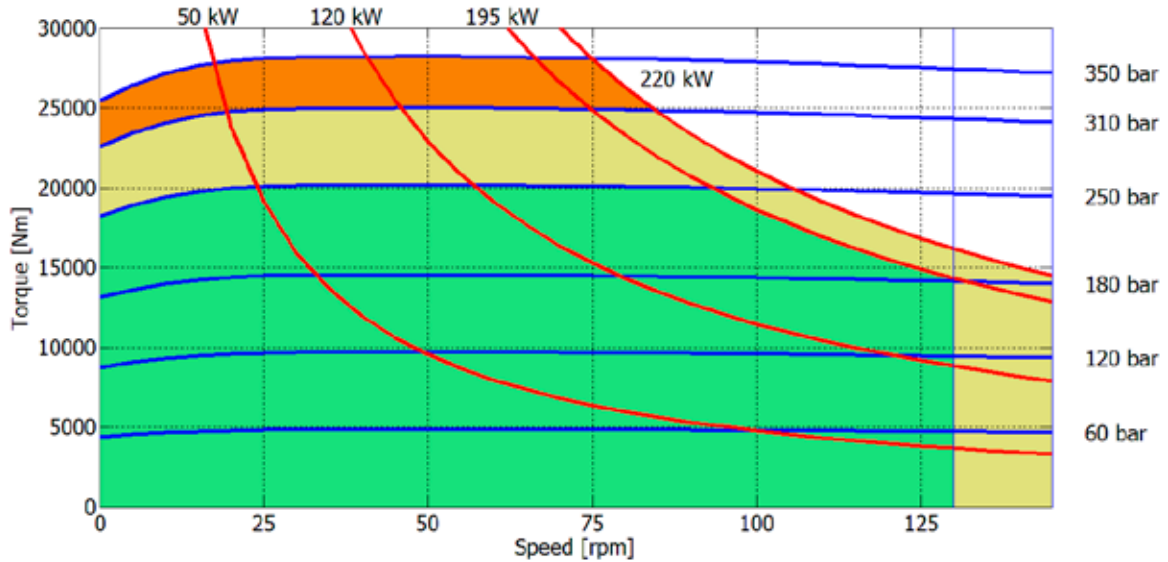

2620 cc - WITHOUT FLUSHING

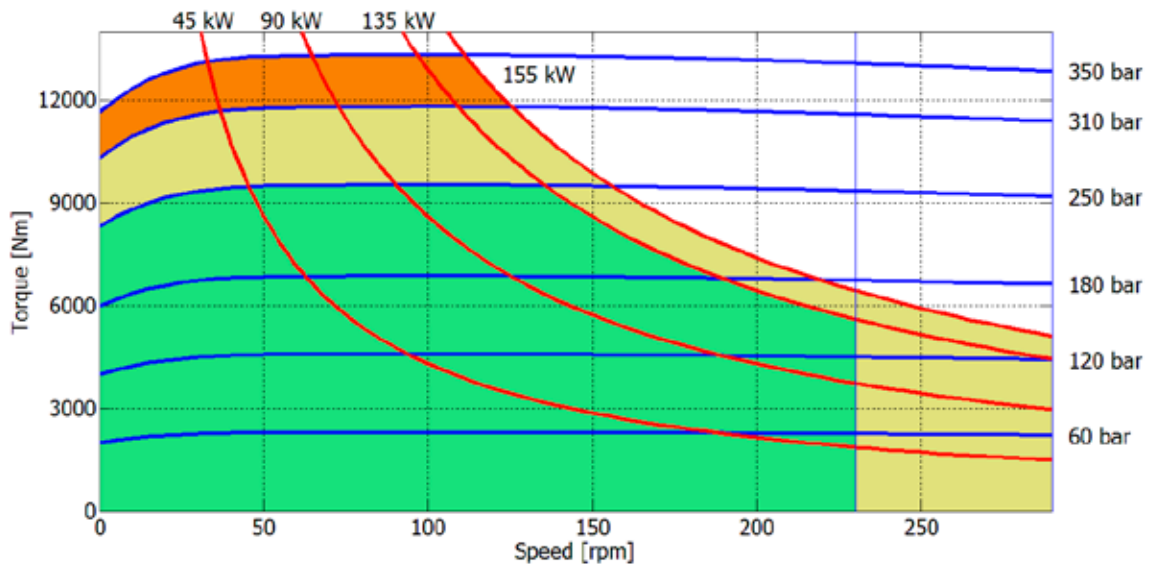

- Continuous operation
- Intermittent operation: permitted for a 15% of duty cycle, for 3 minutes maximum period.
- Peak operation: permitted for very short periods (3-5 seconds every 10-15 minutes).

The above diagrams are referring to the hydraulic motor working with a fluid in ideal conditions (viscosity at 40 cSt). In case the working temperature increases and viscosity reach values under the recommended values (see hydraulic fluid recommendations) flushing must be performed or ISO oil grade must be changed. The working temperature must not overcome 70 °C.

The data specified into the catalogue are for product description purpose only and must not be interpreted as warranted characteristics in legal sense. Italgrou S.r.l. reserves the right to implement modifications without notice. All partial or total reproduction and copy without written authorization of Italgrou S.r.l. is strictly forbidden.

5326 cc - WITH FLUSHING

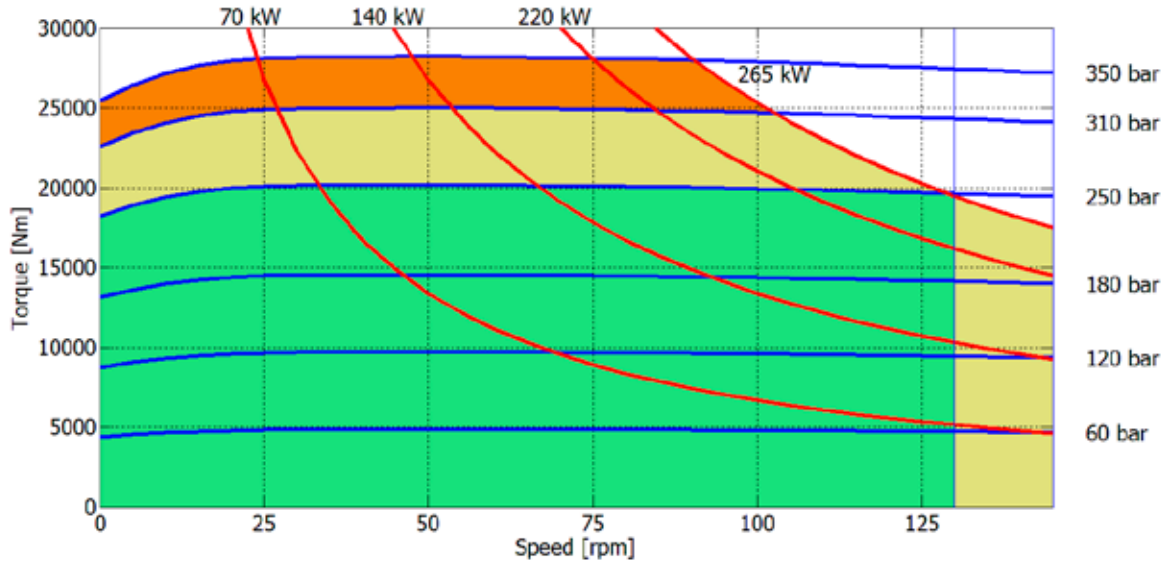

2620 cc - WITH FLUSHING

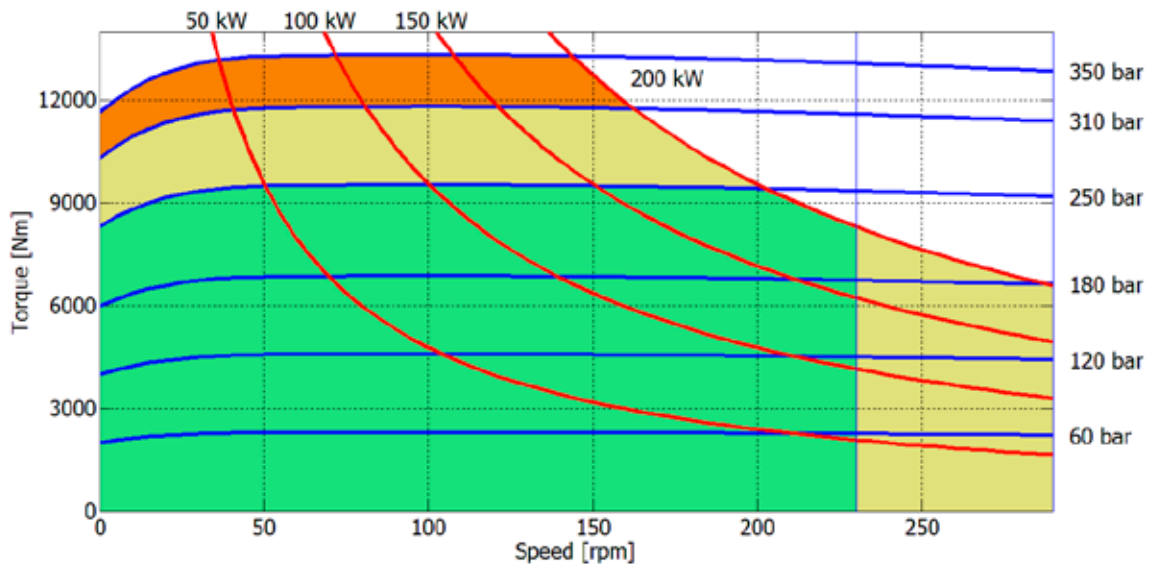

Continuous operation



Intermittent operation: permitted for a 15% of duty cycle, for 3 minutes maximum period.



Peak operation: permitted for very short periods (3-5 seconds every 10-15 minutes).

The above diagrams are referring to the hydraulic motor working with a fluid in ideal conditions (viscosity at 40 cSt). In case the working temperature increases and viscosity reach values under the recommended values (see hydraulic fluid recommendations) flushing must be optimized or ISO oil grade must be changed. The working temperature must not overcome 70 °C.

CREEP SPEED - VOLUMETRIC EFFICIENCY

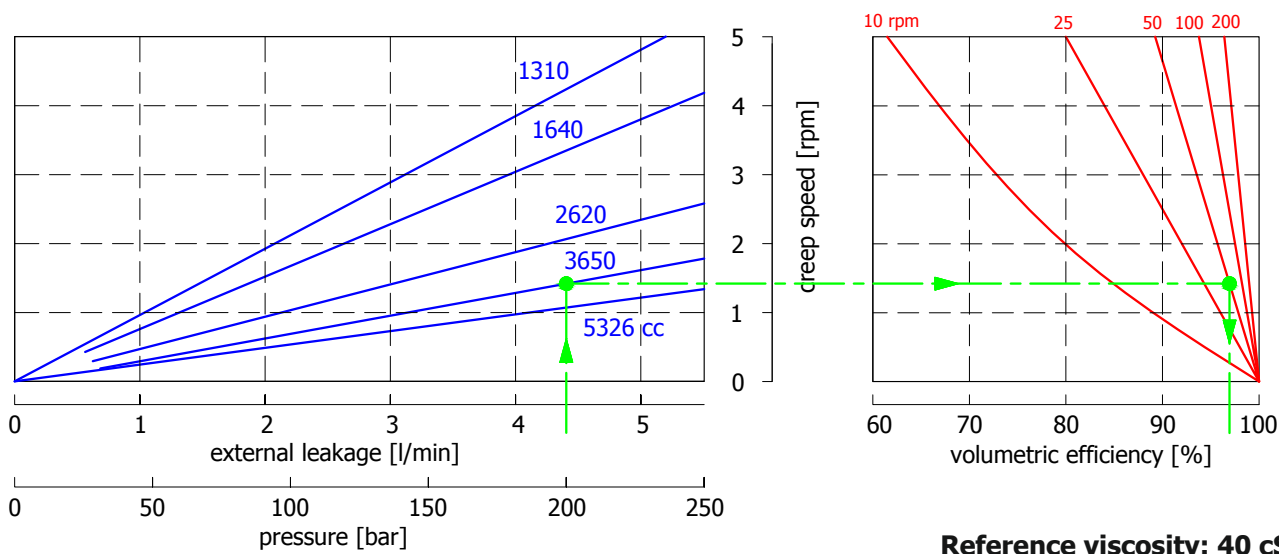

Example:

We suppose (3650 cc): $p=200$ [bar], we obtain: external leakage 4,3 [l/min], shaft creep speed 1,5 [rpm].
If we suppose (3650 cc): $p=200$ [bar] and $n=50$ [rpm] we obtain a volumetric efficiency of 97,5%;

BEARING LIFE

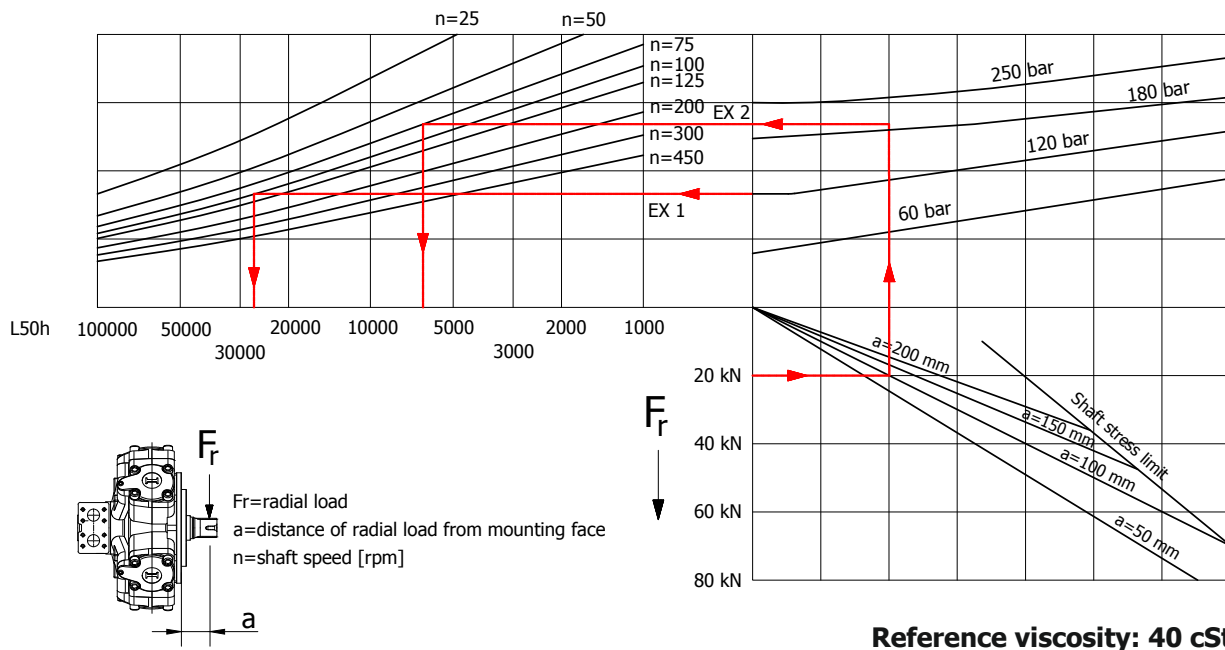

Example:

We suppose (EX1): $p=120$ [bar], $n=100$ [rpm]; we obtain an average lifetime of 31000 [h].
If we suppose (EX2): $F_r=20$ [kN], $a=100$ [mm], $n=75$ [rpm] and $p=180$ [bar] we obtain an average lifetime of 6000 [h].

The data specified into the catalogue are for product description purpose only and must not be interpreted as warranted characteristics in legal sense. Italgrou S.r.l. reserves the right to implement modifications without notice. All partial or total reproduction and copy without written authorization of Italgrou S.r.l. is strictly forbidden.

The data specified into the catalogue are for product description purpose only and must not be interpreted as warranted characteristics in legal sense. Italgroup S.r.l. reserves the right to implement modifications without notice. All partial or total reproduction and copy without written authorization of Italgroup S.r.l. is strictly forbidden.

D40

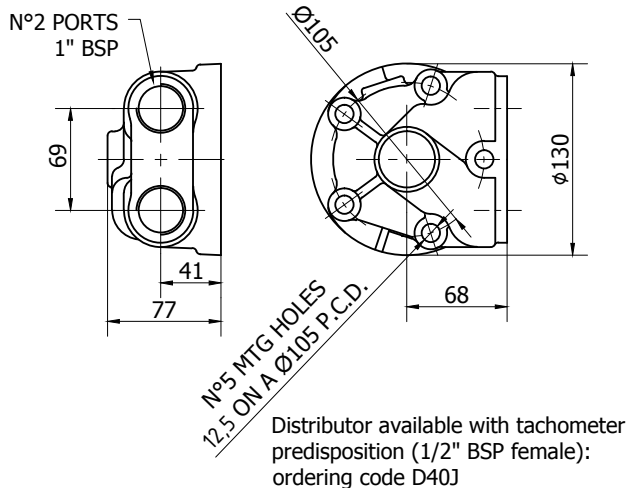

D47

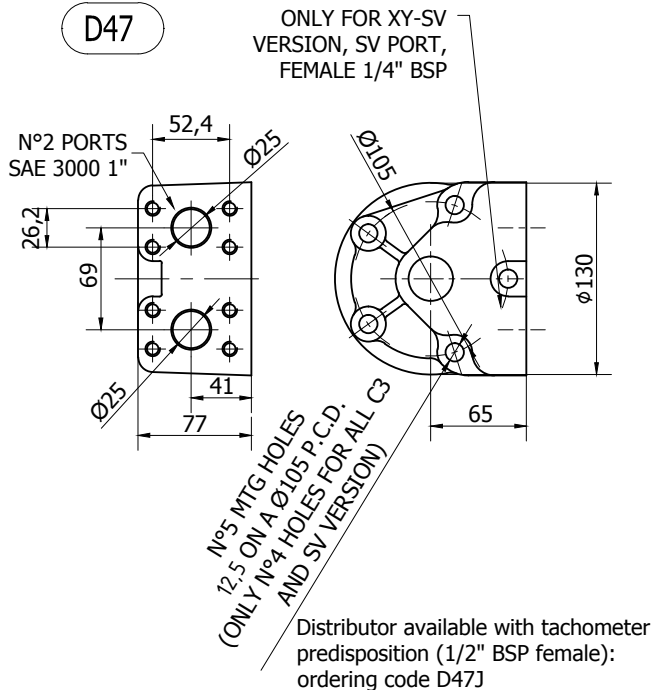

D75

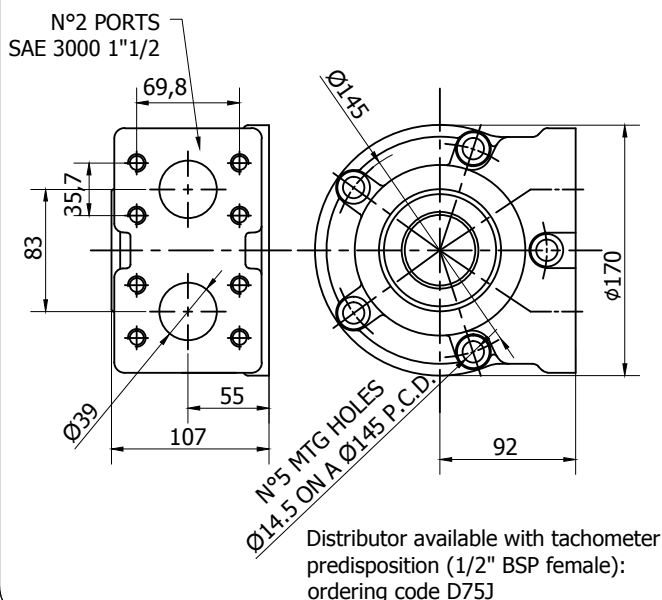

D90

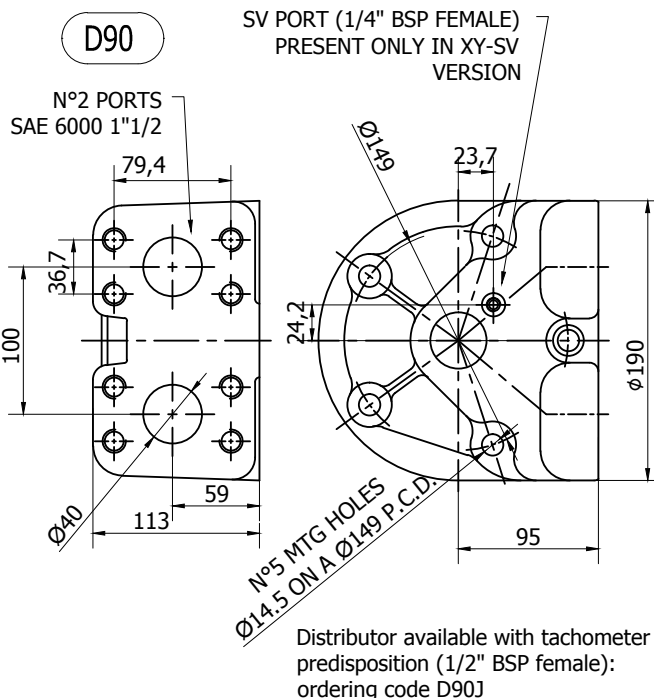

ADAPTOR FLANGES

FL2

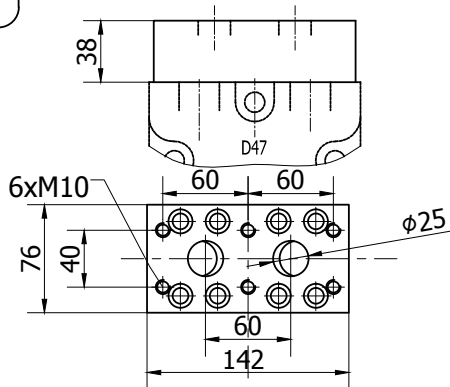

Connection block, fitting D47 distributor, for motor MR 350/450/500/600/700/800

FL4

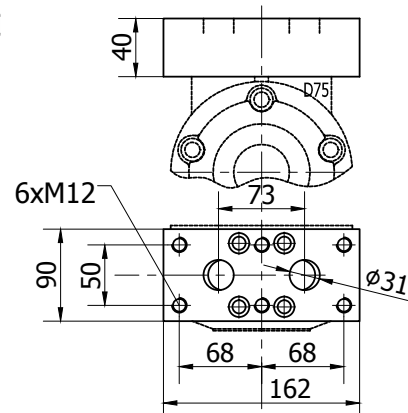

Connection block, fitting D75 distributor, for motor MR 1100/1400/1600/1800/2100

FL5

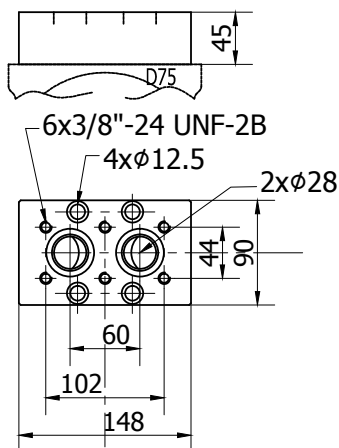

S03 plate for D75

FL6

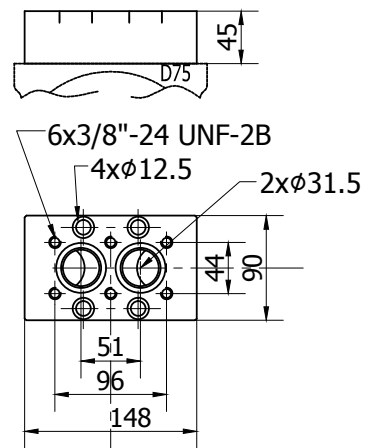

S04 plate for D75

FL7

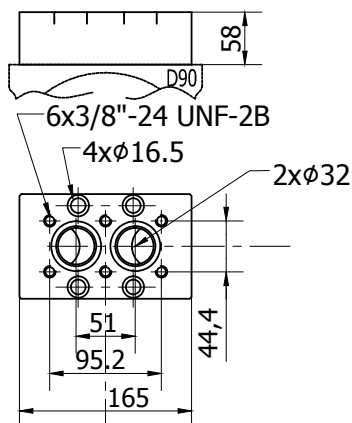

S04 plate for D90

FL10

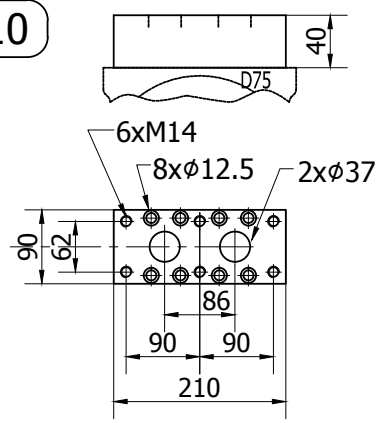

Connection block, fitting D75 distributor, for motor MR 2400/2800/3100

SPLINE BILLETS

SB3

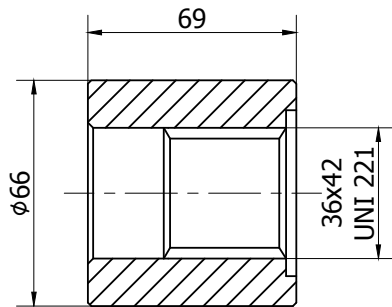

only for:
IAC 500 H3 A0

SB5

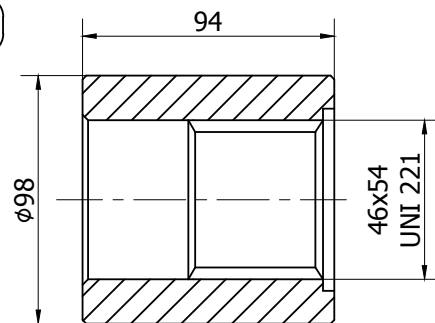

only for:
IAC H3/C A0

SB6

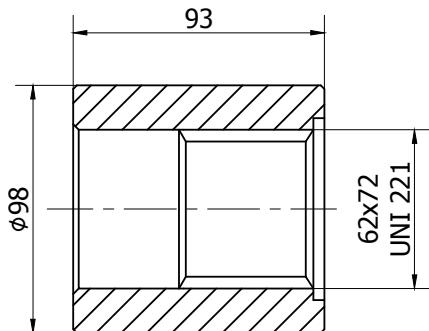

only for:
IAC H5/C A0

SB7

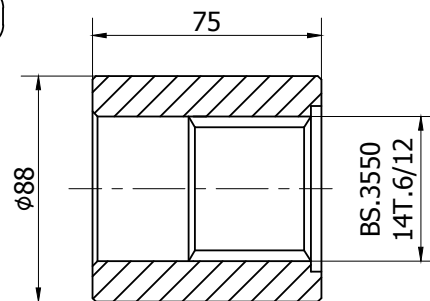

only for:
IAC H5 A1, IAC H5/MRH A1

SB9

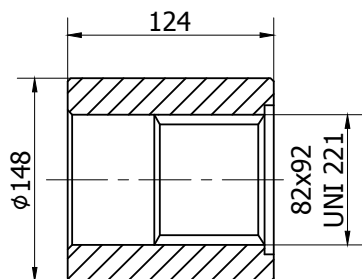

only for:
IAC H6 A0, IAC H6/C A0

SB10

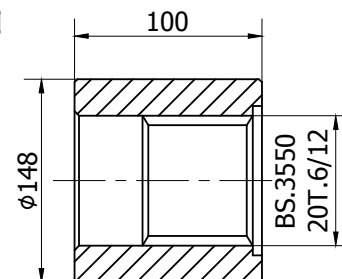

only for:
IAC H6 A1, IAC H6/MRH A1, IAC H7 A1, IAC H7/MRH A1

SB14

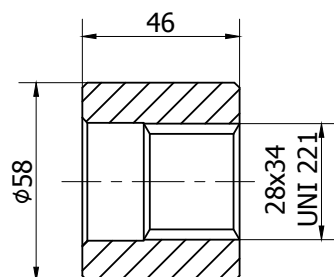

only for:
IAC H1 A0, IAC H1/S A0, IAC H1/BH A0

SB16

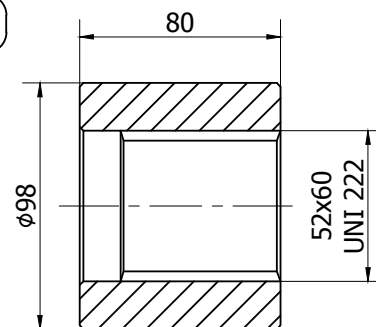

only for:
IAC H4/C A0

The data specified into the catalogue are for product description purpose only and must not be interpreted as warranted characteristics in legal sense. Italgrou S.r.l. reserves the right to implement modifications without notice. All partial or total reproduction and copy without written authorization of Italgrou S.r.l. is strictly forbidden.

SPLINE BILLETS

SB18

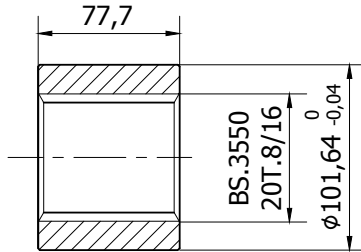

only for:
IAC H4/MRH A1

SB21

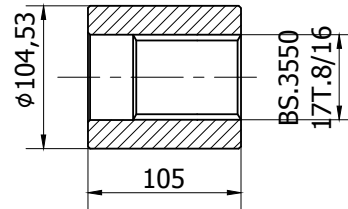

only for:
IAC H3/B30 A1, IAC H3/MRH A1, IAC H4/B45 A1

SB24

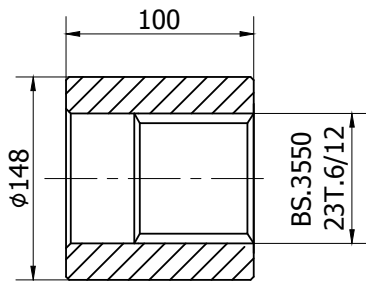

only for:
IAC H6/MRH A13, IAC H7/MRH A13

SB26

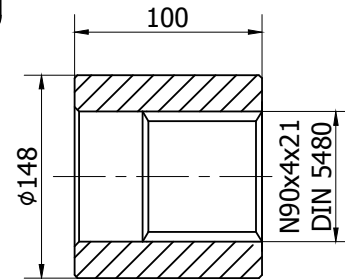

only for:
IAC H7 A11

SB27

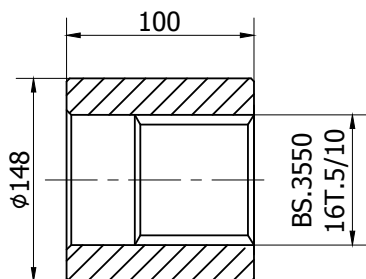

only for:
IAC H6 A12, IAC H7 A12

TA

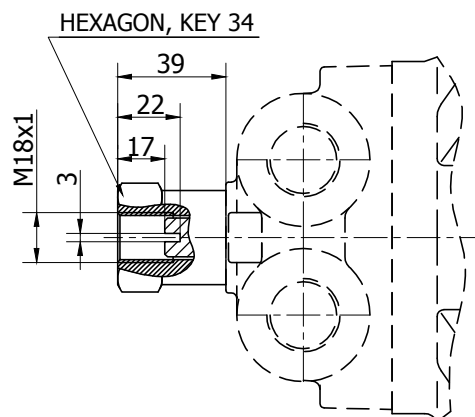

TB

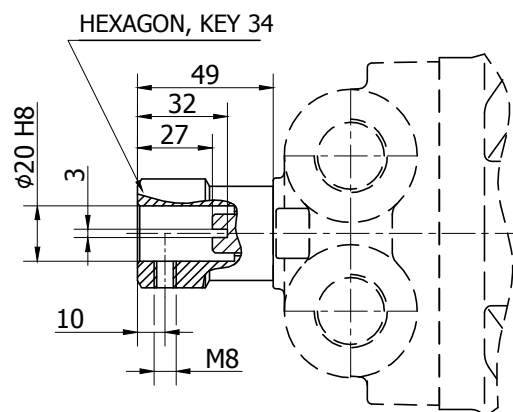

TT1

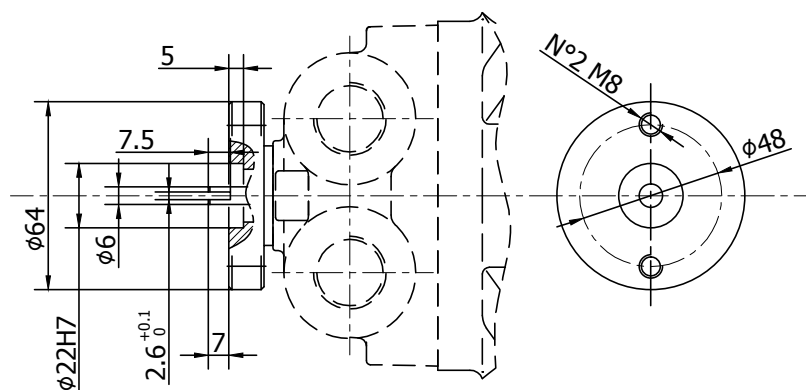

TQ1

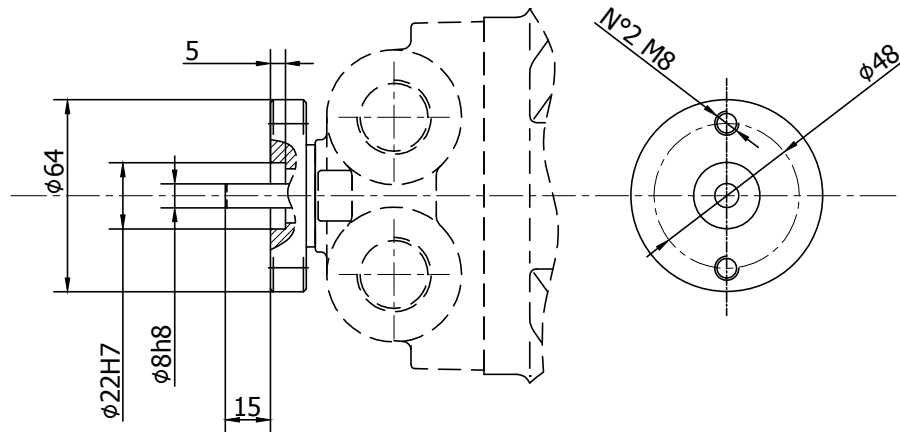

EST

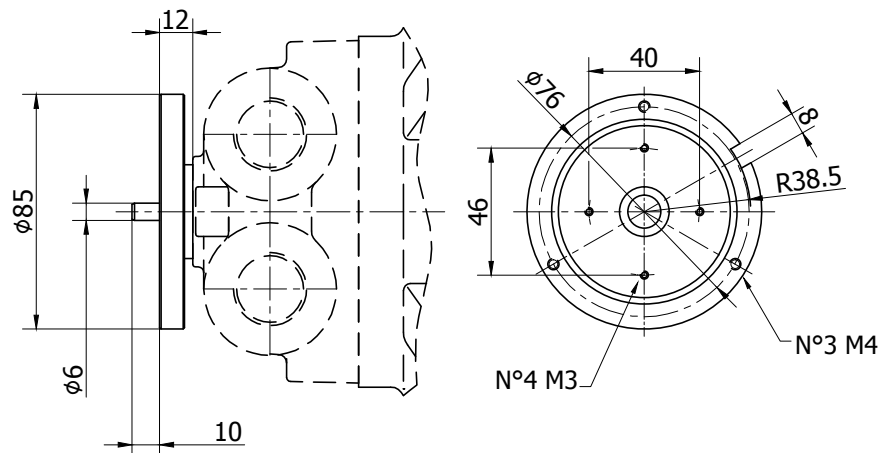

EST30

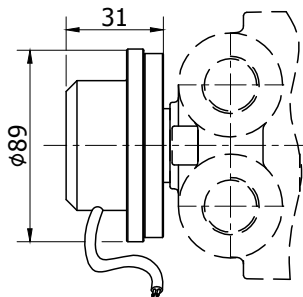

Operating parameters	E-...../3
Power supply (VDC)	10-30
Switching current (mA)	150
Frequency (Hz) 100rpm	50
Impulse/rpm	30
Operating temp. (°C)	-24/+70
Protection degree	IP67
Output	NPN
Motor type	All types

Model	Output	Fig.
E-...../..AP/....	PNP	D

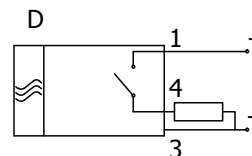

MODEL	φ6
Torque	1 Nm

EST31

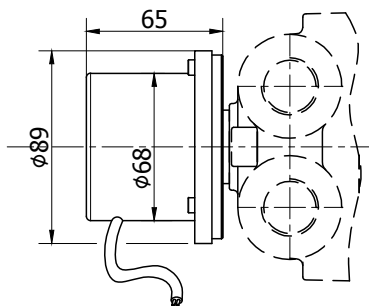

Power supply (VDC)	8-24
Impulse/rpm	500
Operating temp. (°C)	-0/+60
Protection degree	IP65
Output	Push-pull
Motor type	All types
MODEL	φ6
Torque	1 Nm

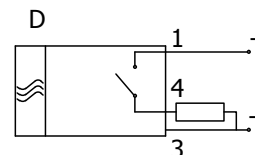

ITALGROUP MOTORS

IAC SERIES - VALVES

TECHNICAL CATALOGUE

INDEX - VALVES

<u>SINGLE OVERCENTER - OVSA 160</u>	Pag.	94
<u>DOUBLE OVERCENTER - OVDA 160</u>	"	95
<u>FLUSHING - AP 40</u>	"	96
<u>DOUBLE RELIEF - RVDA 80</u>	"	97
<u>DOUBLE RELIEF AND FLUSHING - RVDAP 80</u>	"	98
<u>SINGLE RELIEF AND ANTICAVITATION - RVSAC 200</u>	"	99
<u>DOUBLE OVERCENTER - OVDA 300</u>	"	100
<u>DOUBLE RELIEF - RVDA 200</u>	"	101
<u>DOUBLE OVERCENTER - OVDA 480</u>	"	102
<u>DOUBLE RELIEF - RVDA 380</u>	"	103
<u>DOUBLE RELIEF AND FLUSHING - RVDAP 90</u>	"	104
<u>VALVES ORDERING CODE</u>	"	105

SINGLE OVERCENTER VALVE - OVSA 160

INSTALLATION DRAWING

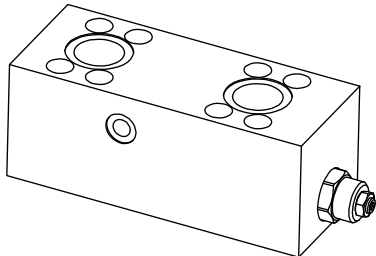

PORTS DIMENSION

V1,V2	1" BSP
F	1/4" BSP
C1,C2	O-ring 4137 Parker code 2-220

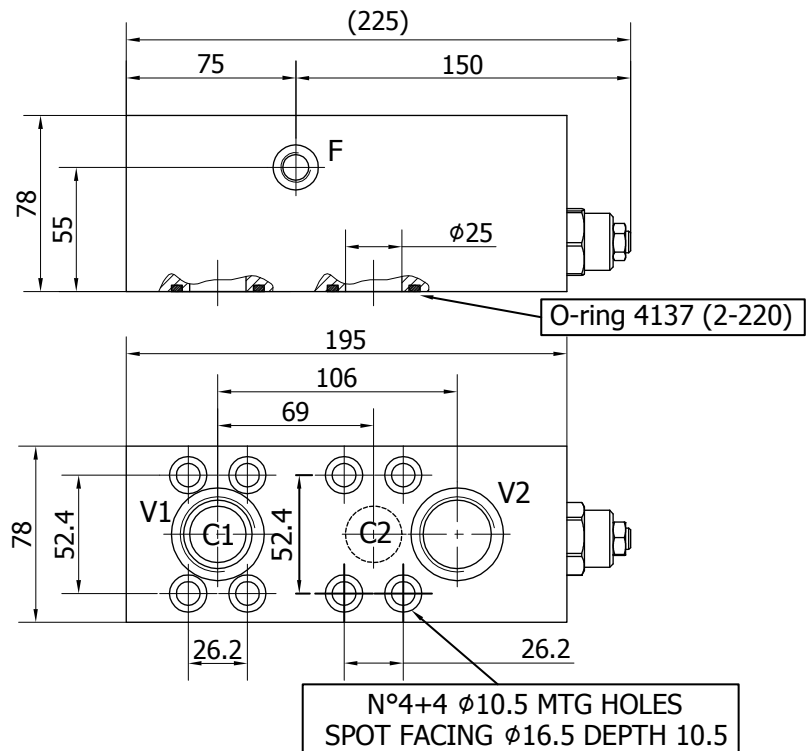

TECHNICAL DATA - OVSA 160

		OVSA.160.1.A.D47	OVSA.160.2.C.D47	OVSA.160.3.C.D47
NOMINAL FLOW	[l/min]	120	120	120
MAXIMUM FLOW	[l/min]	160	160	160
MAXIMUM PRESSURE	[bar]	350	350	350
PILOT RATIO	[-]	3:1	4.5:1	10:1
RELIEF VALVE SETTING RANGE	[bar]	70-280	140-350	140-350
STANDARD RELIEF SETTING	[bar]	210	210	210
BLOCK MATERIAL	[-]	steel	steel	steel
DISTRIBUTOR FITTING	[-]	D47	D47	D47

- (*) Standard version. Usually ready on stock.

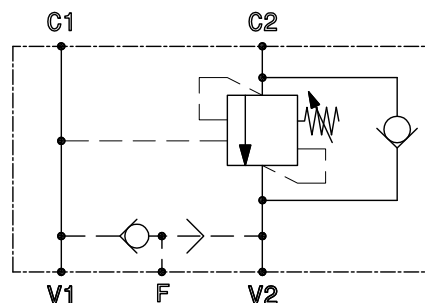
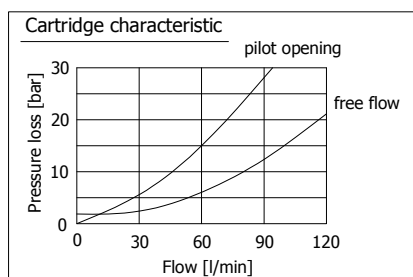

The data specified into the catalogue are for product description purpose only and must not be interpreted as warranted characteristics in legal sense. Italgroup S.r.l. reserves the right to implement modifications without notice. All partial or total reproduction and copy without written authorization of Italgroup S.r.l. is strictly forbidden.

DOUBLE OVERCENTER VALVE - OVDA 160

INSTALLATION DRAWING

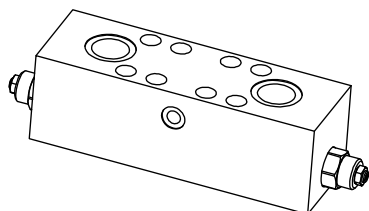

PORTS DIMENSION

V1,V2	1" BSP
F	1/4" BSP
C1,C2	O-ring 4137 Parker code 2-220

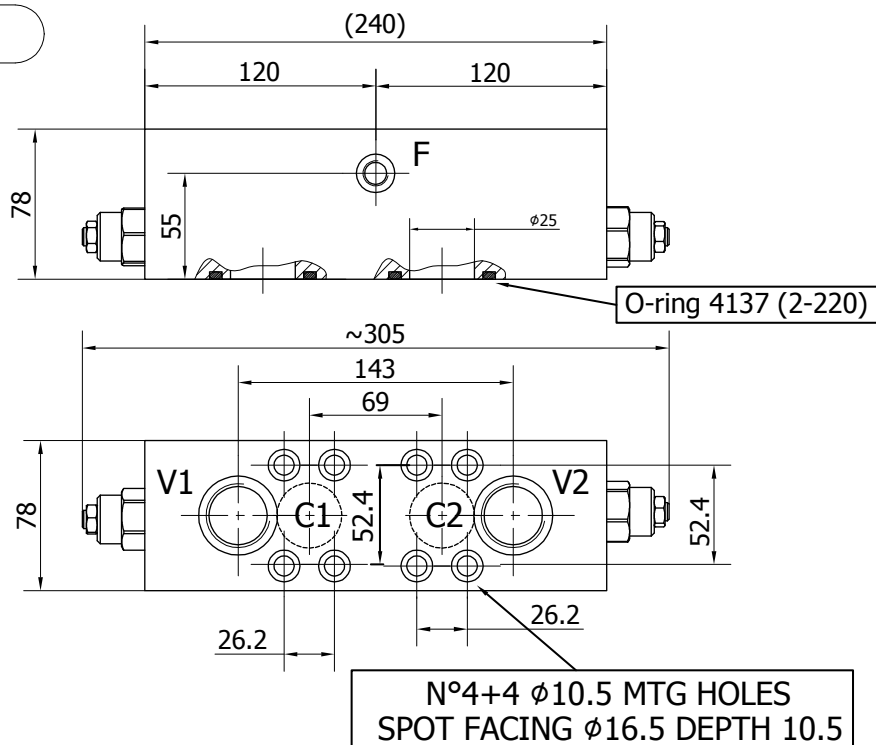

TECHNICAL DATA - OVDA 160

		OVDA.160.1.A.D47	OVDA.160.2.C.D47	OVDA.160.3.C.D47
NOMINAL FLOW	[l/min]	120	120	120
MAXIMUM FLOW	[l/min]	160	160	160
MAXIMUM PRESSURE	[bar]	350	350	350
PILOT RATIO	[-]	3:1	4.5:1	10:1
RELIEF VALVE SETTING RANGE	[bar]	70-280	140-350	140-350
STANDARD RELIEF SETTING	[bar]	210	210	210
BLOCK MATERIAL	[-]	steel	steel	steel
DISTRIBUTOR FITTING	[-]	D47	D47	D47

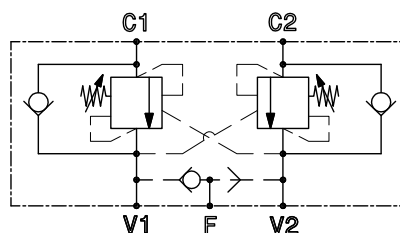
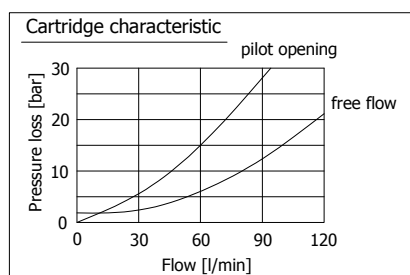

The data specified into the catalogue are for product description purpose only and must not be interpreted as warranted characteristics in legal sense. ItalgrouP S.r.l. reserves the right to implement modifications without notice. All partial or total reproduction and copy without written authorization of ItalgrouP S.r.l. is strictly forbidden.

FLUSHING VALVE - AP40

INSTALLATION DRAWING

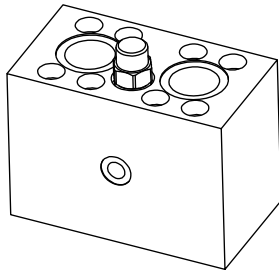

PORTS DIMENSION

V1,V2	1" BSP
F	1/4" BSP
C1,C2	O-ring 4137 Parker code 2-220

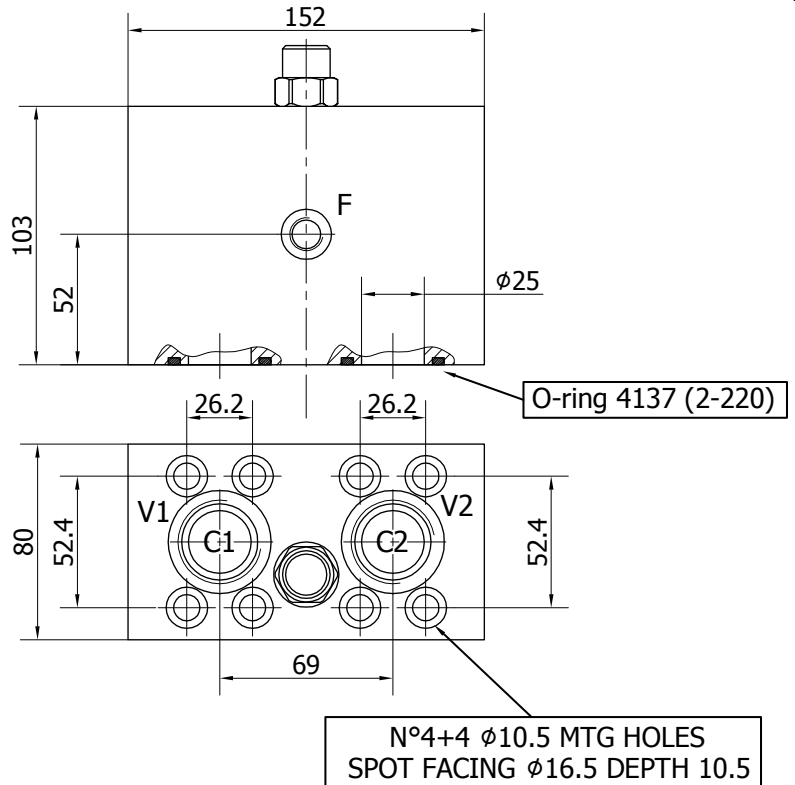

TECHNICAL DATA - AP40

AP40.D47

MAXIMUM FLUSHING FLOW	[l/min]	80
MAXIMUM PRESSURE	[bar]	350
BLOCK MATERIAL	[]	steel
DISTRIBUTOR FITTING	[]	D47

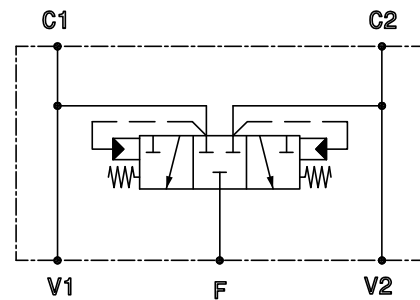
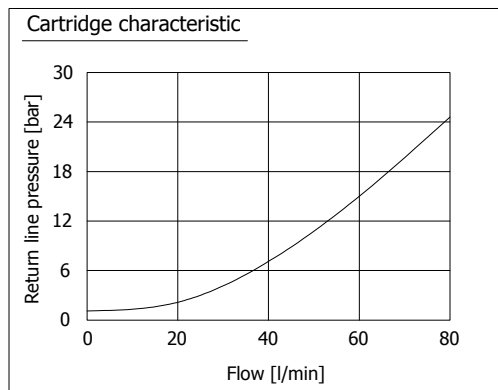

The data specified into the catalogue are for product description purpose only and must not be interpreted as warranted characteristics in legal sense. Italgrou S.r.l. reserves the right to implement modifications without notice. All partial or total reproduction and copy without written authorization of Italgrou S.r.l. is strictly forbidden.

DOUBLE RELIEF VALVE- RVDA 80

INSTALLATION DRAWING

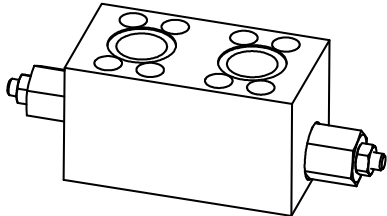

PORTS DIMENSION

V1,V2	1" BSP
C1,C2	O-ring 4137 Parker code 2-220

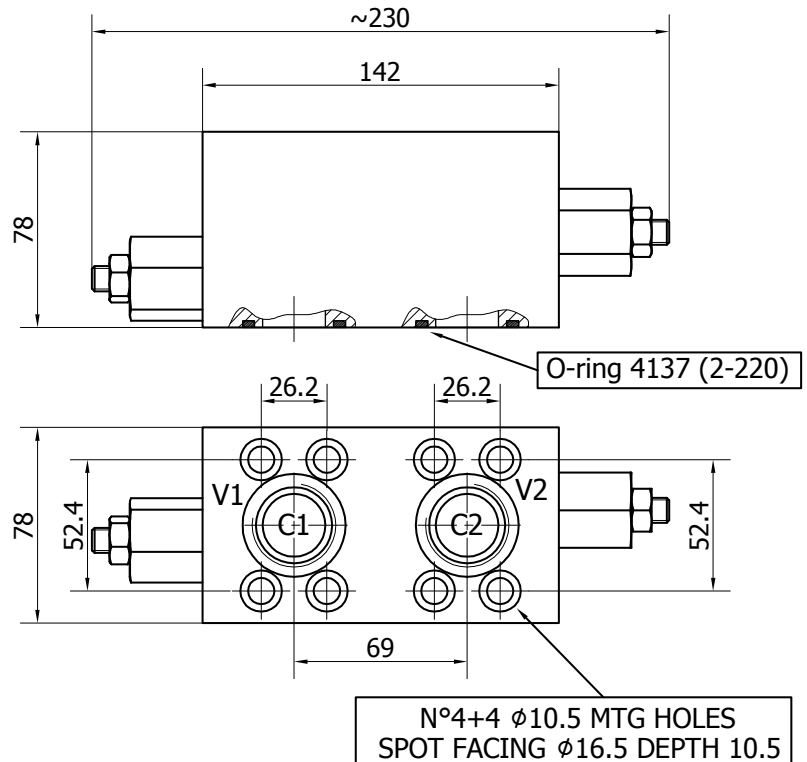

TECHNICAL DATA - RVDA 80

RVDA.80.C.D47

NOMINAL FLOW	[l/min]	150
MAXIMUM FLOW	[l/min]	200
MAXIMUM PRESSURE	[bar]	350
RELIEF VALVE SETTING RANGE	[bar]	20-350
STANDARD RELIEF SETTING	[bar]	20
BLOCK MATERIAL	[]	steel
DISTRIBUTOR FITTING	[]	D47

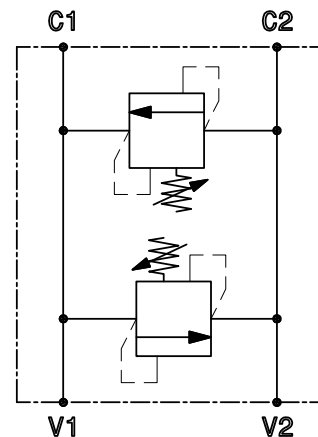
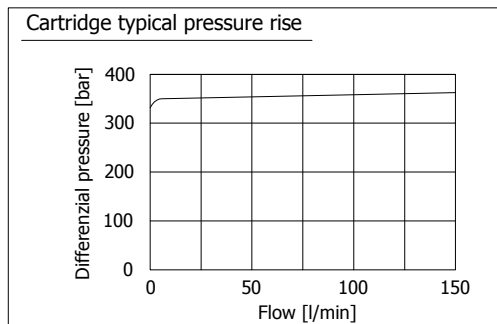

The data specified into the catalogue are for product description purpose only and must not be interpreted as warranted characteristics in legal sense. ItalgrouP S.r.l. reserves the right to implement modifications without notice. All partial or total reproduction and copy without written authorization of ItalgrouP S.r.l. is strictly forbidden.

DOUBLE RELIEF WITH FLUSHING - RVDAP80

INSTALLATION DRAWING

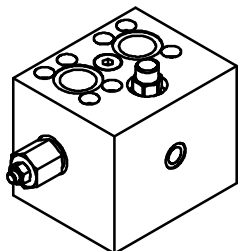

PORTS DIMENSION

V1,V2	1" BSP
F	1/4" BSP
C1,C2	O-ring 4137 Parker code 2-220

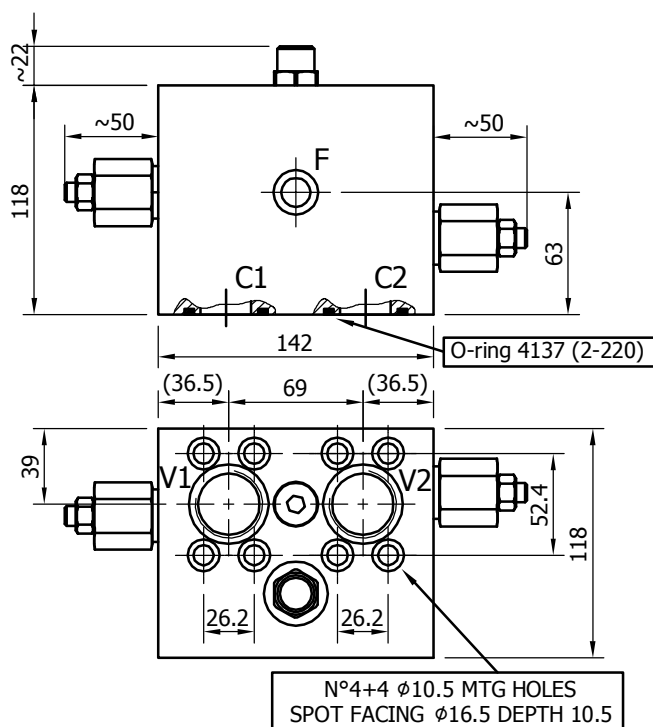

TECHNICAL DATA - RVDAP 80

RVDAP 80		
RELIEF VALVE MAXIMUM FLOW	[l/min]	200
RELIEF VALVE SETTING RANGE	[bar]	20-350
STANDARD RELIEF SETTING	[bar]	70
MAXIMUM FLUSHING FLOW	[l/min]	80
MAXIMUM PRESSURE	[bar]	350
BLOCK MATERIAL	[]	steel
DISTRIBUTOR FITTING	[]	D47

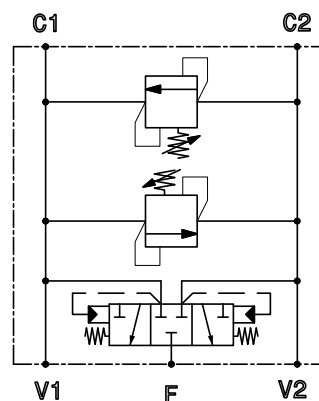

Relief cartridge typical pressure rise

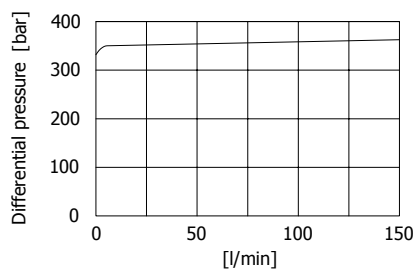

Flushing valve characteristic

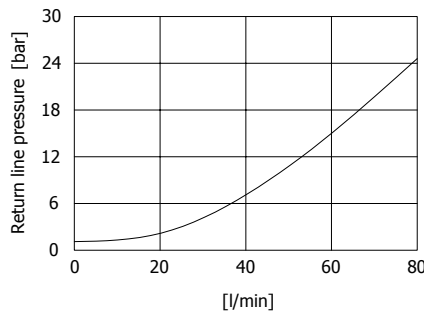

The data specified into the catalogue are for product description purpose only and must not be interpreted as warranted characteristics in legal sense. Italgrou S.r.l. reserves the right to implement modifications without notice. All partial or total reproduction and copy without written authorization of Italgrou S.r.l. is strictly forbidden.

SINGLE RELIEF / ANTICAVITATION- RVSAC200

INSTALLATION DRAWING

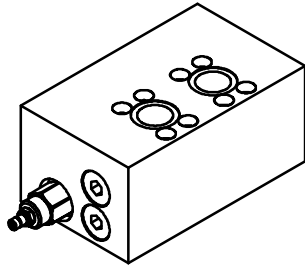

PORTS DIMENSION

V1,V2	1" BSP
M1,M2	1/4" BSP
C1,C2	O-ring 4137 Parker code 2-220

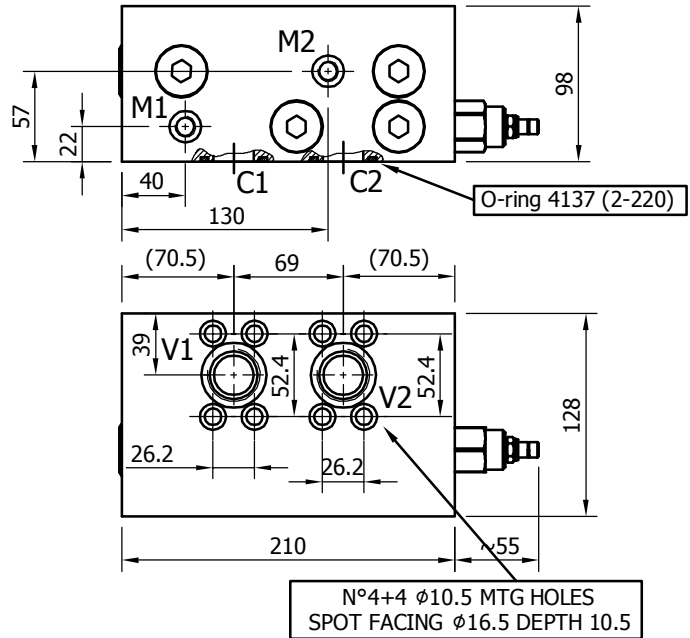

TECHNICAL DATA - RVSAC 200

		RVSAC200
RELIEF VALVE MAXIMUM FLOW	[l/min]	200
MAXIMUM PRESSURE	[bar]	350
RELIEF VALVE SETTING RANGE	[bar]	70-420
STANDARD RELIEF SETTING	[bar]	70
CHECK VALVE MAXIMUM FLOW	[l/min]	160
BLOCK MATERIAL	[]	steel
DISTRIBUTOR FITTING	[]	D47

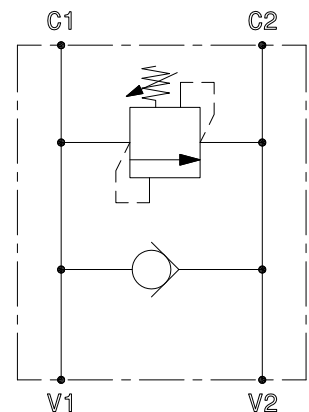

Cartridge typical pressure rise

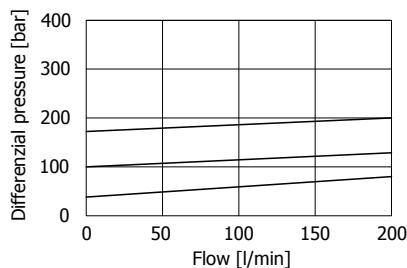

Oil supply flow (from C2 to C1)

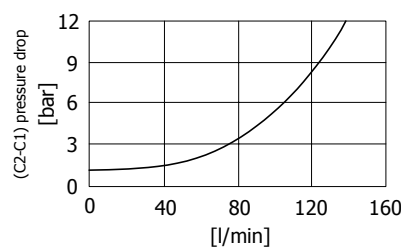

The data specified into the catalogue are for product description purpose only and must not be interpreted as warranted characteristics in legal sense. ItalgrouP S.r.l. reserves the right to implement modifications without notice. All partial or total reproduction and copy without written authorization of ItalgrouP S.r.l. is strictly forbidden.

DOUBLE OVERCENTER VALVE - OVDA 300

INSTALLATION DRAWING

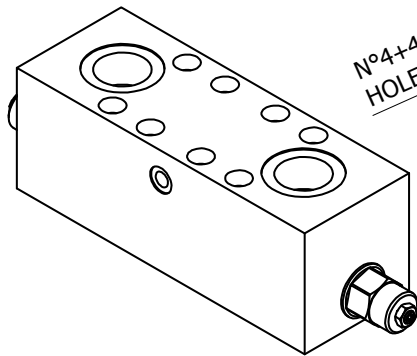

N°4+4 MTG HOLES Ø12,5

PORTS DIMENSION

V1,V2	1"1/4 BSPP
F	1/4" BSPP
C1,C2	O-ring 4187 Parker code 2-225

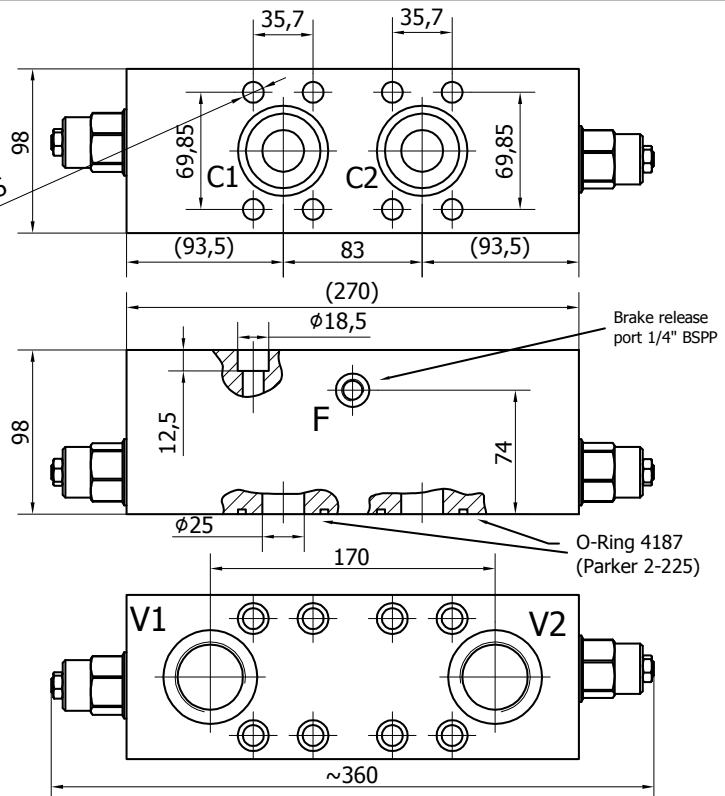

TECHNICAL DATA - OVDA 300

		OVDA.300.1.A.D75	OVDA.300.4.C.D75	OVDA.300.2.C.D75
NOMINAL FLOW	[l/min]	240	240	240
MAXIMUM FLOW	[l/min]	300	300	300
MAXIMUM PRESSURE	[bar]	350	350	350
PILOT RATIO	[-]	3:1	10:1	4.5:1
RELIEF VALVE SETTING RANGE	[bar]	70-280	140-350	140-350
STANDARD RELIEF SETTING	[bar]	210	210	210
BLOCK MATERIAL	[-]	steel	steel	steel
DISTRIBUTOR FITTING	[-]	D75	D75	D75

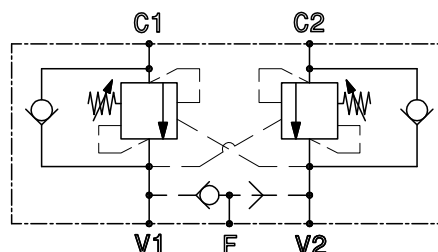
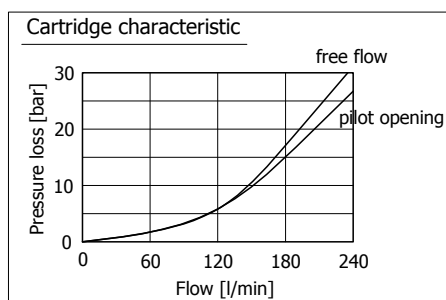

The data specified into the catalogue are for product description purpose only and must not be interpreted as warranted characteristics in legal sense. Italgrou S.r.l. reserves the right to implement modifications without notice. All partial or total reproduction and copy without written authorization of Italgrou S.r.l. is strictly forbidden.

DOUBLE RELIEF VALVE- RVDA 200

INSTALLATION DRAWING

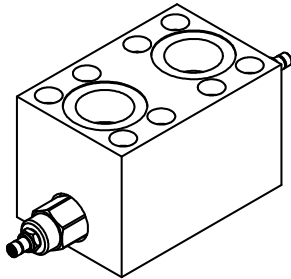

PORTS DIMENSION

V1,V2	1"1/4 BSP
C1,C2	O-ring 4187 Parker code 2-225

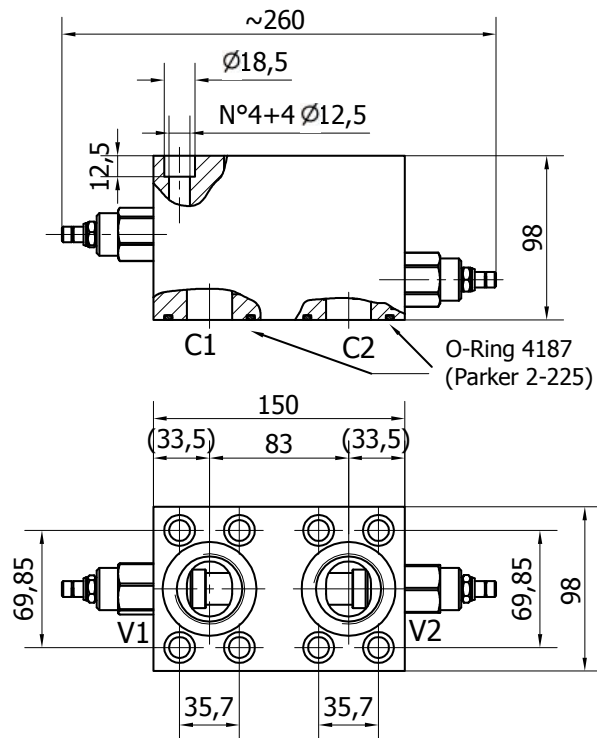

TECHNICAL DATA - RVDA 200

RVDA.200.C.D75

RELIEF VALVE MAXIMUM FLOW	[l/min]	200
MAXIMUM PRESSURE	[bar]	350
RELIEF VALVE SETTING RANGE	[bar]	70-420
STANDARD RELIEF SETTING	[bar]	70
BLOCK MATERIAL	[]	steel
DISTRIBUTOR FITTING	[]	D75

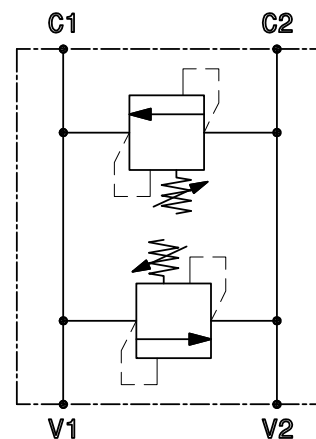
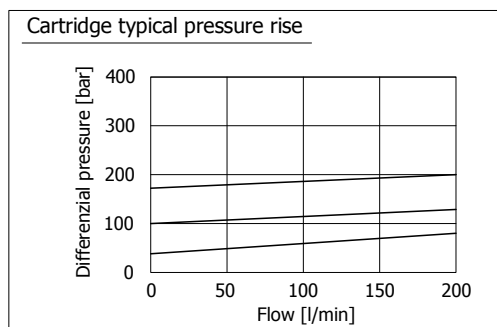

The data specified into the catalogue are for product description purpose only and must not be interpreted as warranted characteristics in legal sense. ItalgrouP S.r.l. reserves the right to implement modifications without notice. All partial or total reproduction and copy without written authorization of ItalgrouP S.r.l. is strictly forbidden.

DOUBLE OVERCENTER VALVE - OVDA 480

INSTALLATION DRAWING

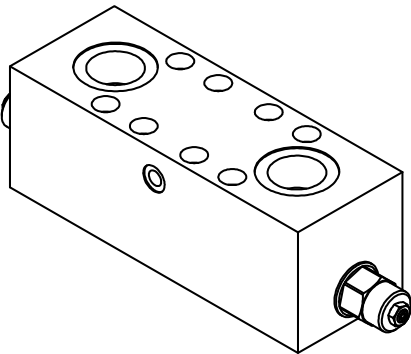

PORTS DIMENSION

V1,V2	1"1/2 BSPP
F	1/4" BSPP
C1,C2	O-ring 4187 Parker code 2-225

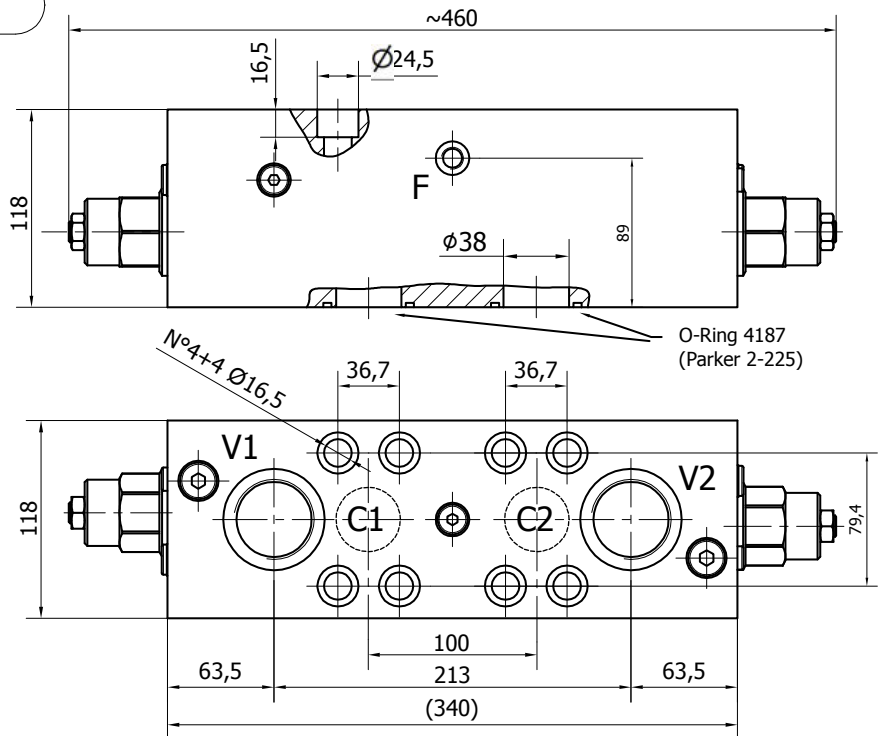

TECHNICAL DATA - OVDA 480

		OVDA.480.1.A.D90	OVDA.480.4.C.D90	OVDA.480.2.C.D90
NOMINAL FLOW	[l/min]	480	480	480
MAXIMUM FLOW	[l/min]	600	600	600
MAXIMUM PRESSURE	[bar]	350	350	350
PILOT RATIO	[-]	3:1	10:1	4.5:1
RELIEF VALVE SETTING RANGE	[bar]	70-280	140-350	140-350
STANDARD RELIEF SETTING	[bar]	210	210	210
BLOCK MATERIAL	[-]	steel	steel	steel
DISTRIBUTOR FITTING	[-]	D90	D90	D90

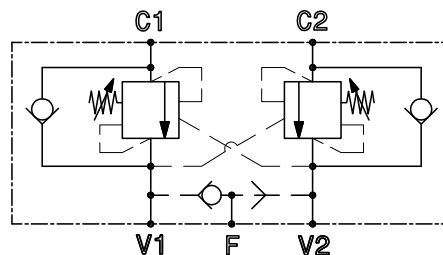
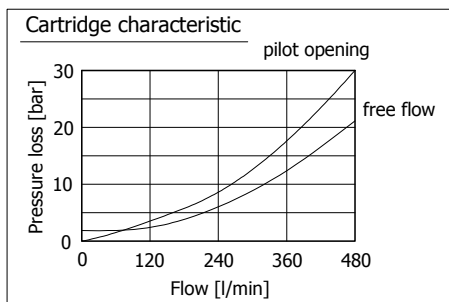

The data specified into the catalogue are for product description purpose only and must not be interpreted as warranted characteristics in legal sense. Italgrou S.r.l. reserves the right to implement modifications without notice. All partial or total reproduction and copy without written authorization of Italgrou S.r.l. is strictly forbidden.

DOUBLE RELIEF VALVE- RVDA 380

INSTALLATION DRAWING

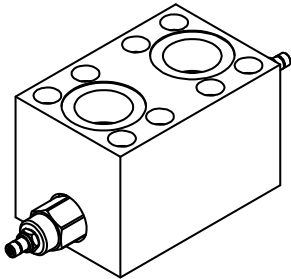

PORTS DIMENSION

V1,V2	1"1/2 BSP
C1,C2	O-ring 4187 Parker code 2-225

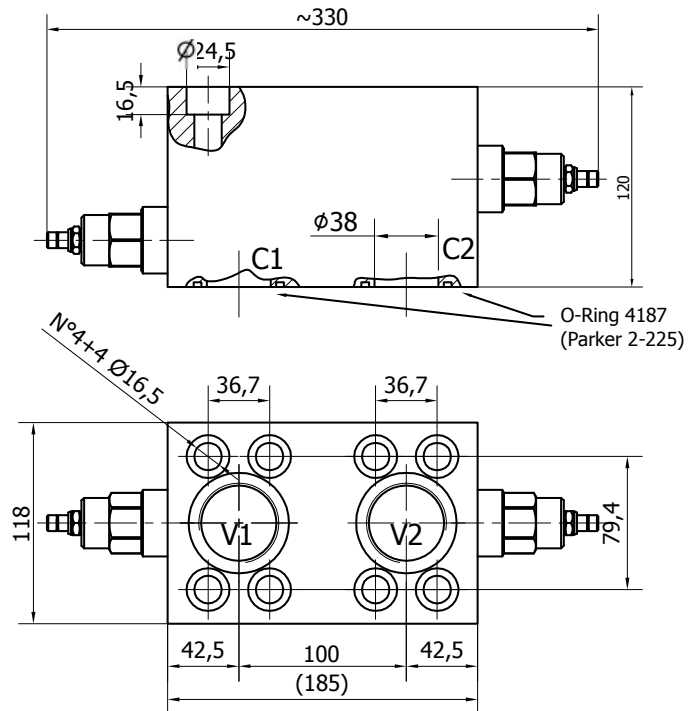

TECHNICAL DATA - RVDA 380

RVDA.380.C.D90

RELIEF VALVE MAXIMUM FLOW	[l/min]	380
MAXIMUM PRESSURE	[bar]	350
RELIEF VALVE SETTING RANGE	[bar]	70-420
STANDARD RELIEF SETTING	[bar]	70
BLOCK MATERIAL	[]	steel
DISTRIBUTOR FITTING	[]	D90

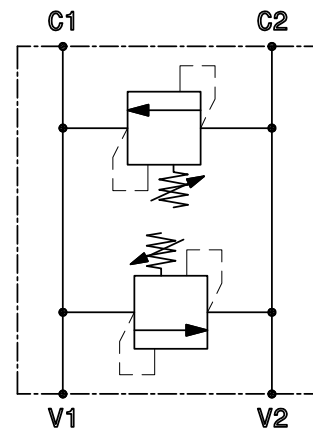
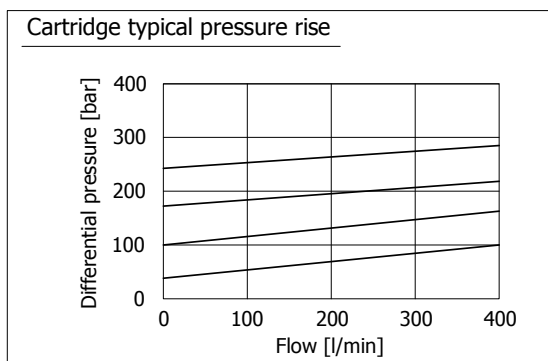

The data specified into the catalogue are for product description purpose only and must not be interpreted as warranted characteristics in legal sense. Italgroup S.r.l. reserves the right to implement modifications without notice. All partial or total reproduction and copy without written authorization of Italgroup S.r.l. is strictly forbidden.

INSTALLATION DRAWING

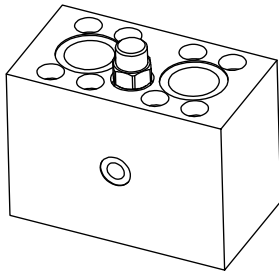

PORTS DIMENSION

V1,V2	1"1/2 BSP
F	1/4" BSP
C1,C2	O-ring 4187 Parker code 2-225

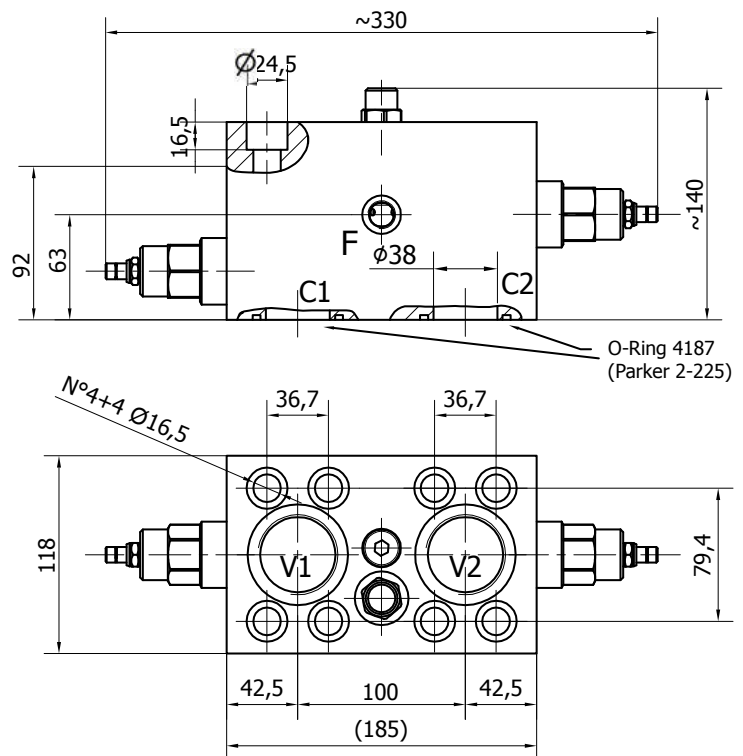

TECHNICAL DATA - RVDAP 90

RVDAP 90		
RELIEF VALVE MAXIMUM FLOW	[l/min]	380
RELIEF VALVE SETTING RANGE	[bar]	70-420
STANDARD RELIEF SETTING	[bar]	70
MAXIMUM FLUSHING FLOW	[l/min]	80
MAXIMUM PRESSURE	[bar]	350
BLOCK MATERIAL	[]	steel
DISTRIBUTOR FITTING	[]	D90

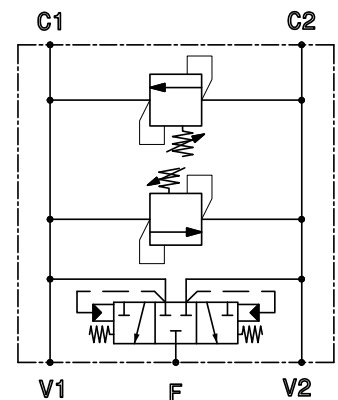
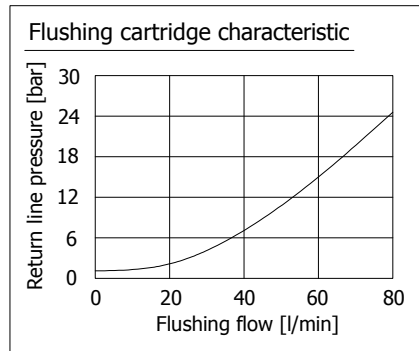
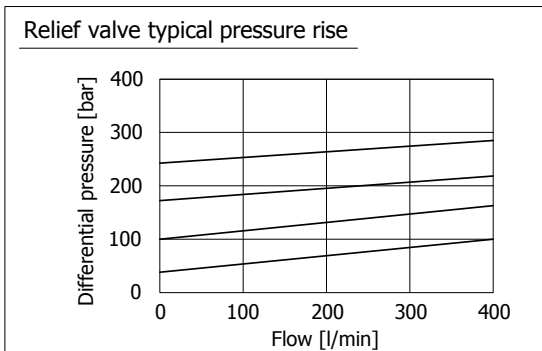

The data specified into the catalogue are for product description purpose only and must not be interpreted as warranted characteristics in legal sense. Italgroup S.r.l. reserves the right to implement modifications without notice. All partial or total reproduction and copy without written authorization of Italgroup S.r.l. is strictly forbidden.

VALVES ORDERING CODE

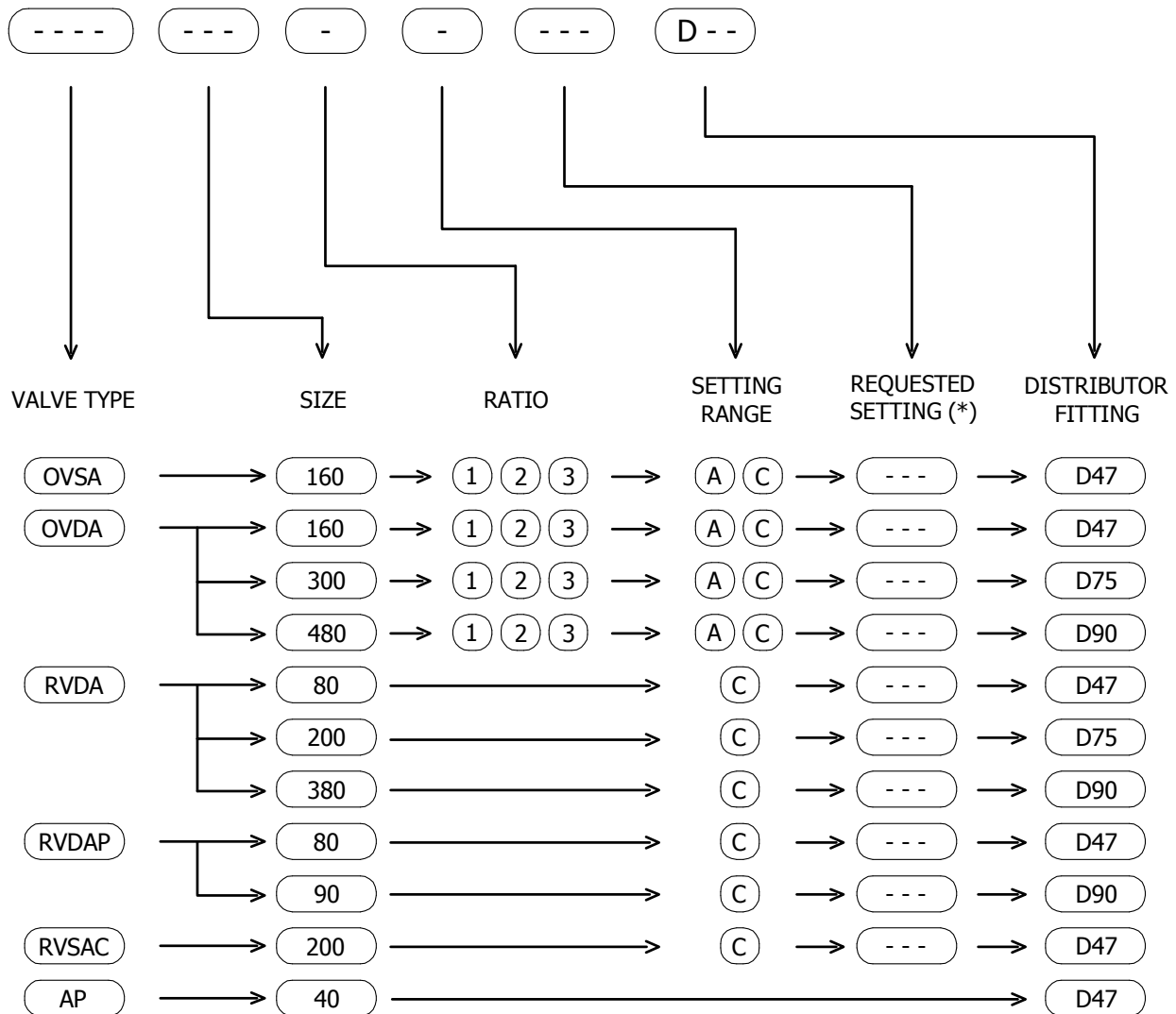

(*) If not specified, the valve will be supplied with the standard setting. Refer to the valves datasheets for the standard setting value.

EXAMPLES:

OVDA 160 1 A 200 D47

AP40 D47

RVDA 380 C D90

CONTACT US

Italgroup S.r.l.
Via Pacinotti 20/22
41010 - Gaggio di Piano (Modena) – Italy

Tel. +39 059 92 42 57
Fax +39 059 92 01 13
e-mail: italgroup@italgroup.eu
internet: <http://www.italgroup.eu>

REACH US



Europe

Austria
Belgium
Croatia
Czech Republic
Cyprus
Denmark
Faroe Islands
France
Finland
Germany
Greece
Iceland
Italy
Netherland
Norway
Poland
Portugal
Russia
Slovenia
Spain
Sweden
Switzerland
Turkey
Ukraina
United Kingdom

Africa

Egypt
South Africa
Tunisia

America

Argentina
Brazil
Canada
Chile
Mexico
Peru
USA
Colombia

Asia

China
Hong Kong
India
Indonesia
Iran
Israel
Philippines
Russia
Belarus
Singapore
South Korea
Thailand
Taiwan
United Arab Emirates
Vietnam

Oceania

Australia
New Zeland

